

- Célula de carga de tracción/compresión
- 3000 divisiones O.I.M.L. R60 clase C
- Soporte elástico de acero aleado
- Protección IP 67 (EN 60529)
- Tratamiento anticorrosión de níquel duro
- Aplicaciones:
  - Tanques, Tolvas y Cintas pesadoras suspendidas de estructuras
  - Centrales de asfalto y hormigón
  - Medida de fuerza en maquinaria de ensayo
  - Pesaje aéreo

- Tension/compression load cell
- 3000 divisions O.I.M.L. R60 class C
- Measuring element from Steel alloy
- Protected IP 67 (EN 60529)
- Protected against corrosion by nickel-plated treatment
- Applications:
  - Suspended weighing in Tanks, Hoppers and Belt Conveyor Scales
  - Asphalt and Concrete Plants
  - Force measurement in Test Equipment
  - Crane scales

Modelo Model	Carga nominal Nominal capacity Ln	Clase de precisión Accuracy class n. OIML	División mínima Minimum division vmin	Carga de servicio Service load 150% Ln	Carga límite Safe load 300% Ln
620 50 kg	50 kg	3000	5 g	75 kg	150 kg
620 100 kg	100 kg	3000	10 g	150 kg	300 kg
620 150 kg	150 kg	3000	15 g	225 kg	450 kg
620 200 kg	200 kg	3000	20 g	300 kg	600 kg
620 300 kg	300 kg	3000	30 g	450 kg	900 kg
620 500 kg	500 kg	3000	50 g	750 kg	1500 kg
620 750 kg	750 kg	3000	75 g	1125 kg	2250 kg
620 1000 kg	1000 kg	3000	100 g	1500 kg	3000 kg
620 1500 kg	1500 kg	3000	150 g	2250 kg	4500 kg
620 2000 kg	2000 kg	3000	200 g	3000 kg	6000 kg
620 3000 kg	3000 kg	3000	300 g	4500 kg	9000 kg
620 5000 kg	5000 kg	3000	500 g	7500 kg	15000 kg
620 6000 kg	6000 kg	3000	600 g	9000 kg	18000 kg

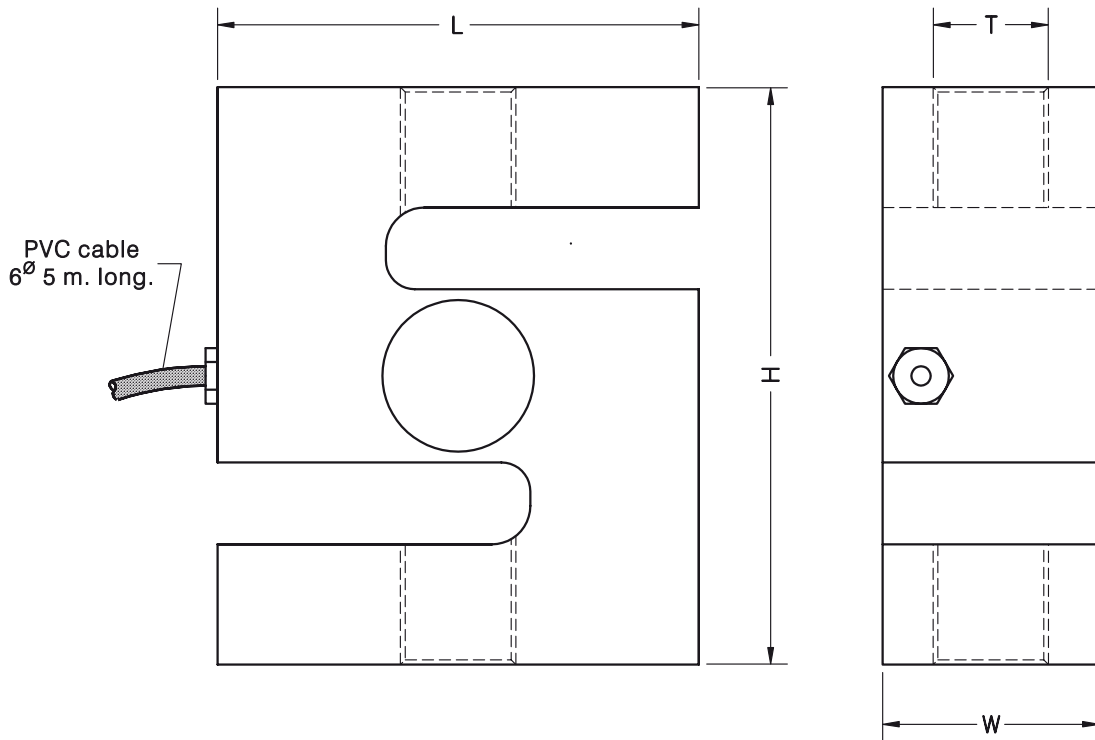

Carga nominal Nominal load	L	H	T	W	Peso transporte Transport weight
50...1000 kg	62.1	80	M12x1.75	19	0.7 kg
1500-2000 kg	70	90	M16x2	32	1.3 kg
3000...6000 kg	100	120	M24x2	45	3.3 kg

Dimensiones en mm. *Dimensions in mm.*

ESPECIFICACIONES			SPECIFICATIONS
Cargas nominales (Ln)	50-100-150 200-300-500 750-1000-1500 2000-3000 5000-6000	kg	Nominal capacities (Ln)
Clase de precisión	3000	n. OIML	Accuracy class
Carga mínima	0	%Ln	Minimum dead load
Carga de servicio	150	%Ln	Service load
Cargas límite	300	%Ln	Safe load limit
Error combinado	< ±0.017	%Sn	Total error
Error repetibilidad	< ±0.015	%Sn	Repeatability error
Efecto de la temperatura: en el cero en la sensibilidad	< ±0.01 < ±0.006	%Sn/5°K %Sn/5°K	Temperature effect: on zero on sensitivity
Error de fluencia (30 minutos)	< ±0.016	%Sn	Creep error (30 minutes)
Compensación de temperatura	-10...+40	°C	Temperature compensation
Límites de temperatura	-30...+70	°C	Temperature limits
Sensibilidad nominal (Sn)	2 ±0.1%	mV/V	Nominal sensitivity (Sn)
Tensión de alimentación nominal	10	V	Nominal input voltage
Tensión de alimentación máxima	15	V	Maximum input voltage
Resistencia de entrada	400 ±20	Ω	Input impedance
Resistencia de salida	350 ±3	Ω	Output impedance
Desequilibrio inicial	< ±2	%Sn	No load output
Resistencia de aislamiento	> 5000	MΩ	Insulation resistance
Deformación máxima (a Ln)	0.3-0.5	mm	Maximum deflection (at Ln)

CONEXION ELECTRICA  
ELECTRICAL CONNECTION:

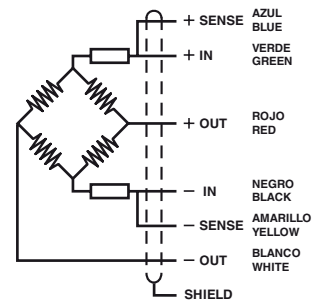

«SENSES»: 2 hilos adicionales, para mantener constante la alimentación en la célula, con una instrumentación adecuada. Utilizar especialmente para cables largos y amplio margen de temperatura.  
PANTALLA: No conectada al cuerpo del transductor.

«CONVENIO SIGNOS SALIDA PARA TRACCION»

«SENSES»: 2 additional wires to maintain a constant voltage supply at the load cell when used with proper instrumentation. Use specially when long wires and wide temperature range.  
SHIELD: Not connected to transducer body.

«OUTPUT SIGNS FOR TENSION APPLICATION»

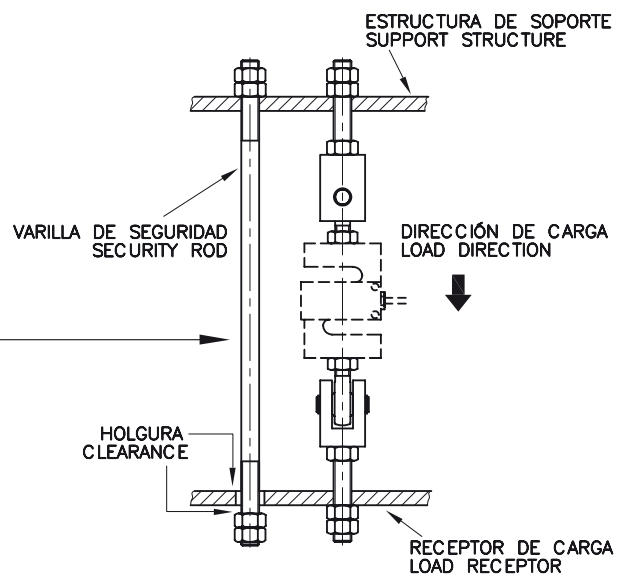
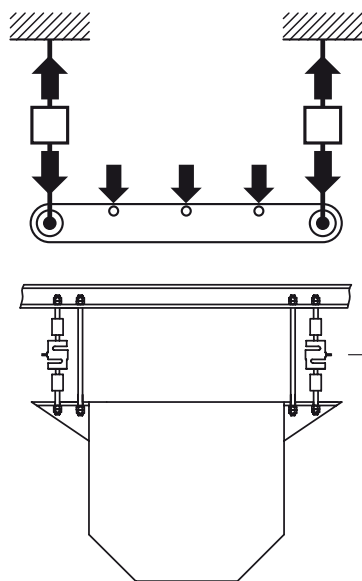
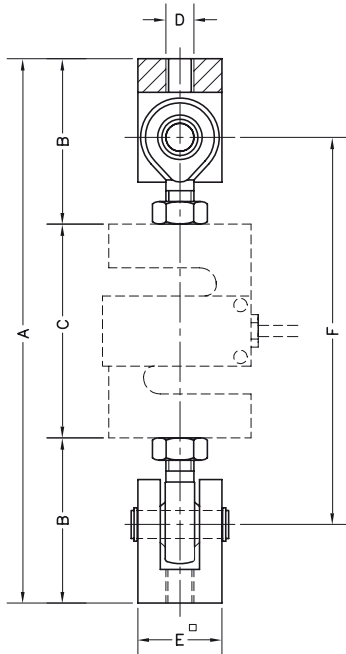
**ACCESORIO TRACCION PARA MOD. 620**  
**TENSION ACCESSORY FOR MODEL 620**

Accesorio Accessory	Carga nominal Nominal load	A	B	C	D	E <sup>□</sup>	F	Carga límite Ultimate load	Peso transporte Transport weight	Material
<b>TE12x1.75</b>	50...1000 kg	246	83	80	M12x1.75	35	158	2580 kg	1.4 kg	Acero cincado Steel zinc-plated
<b>TE16x2</b>	1500-2000 kg	290	100	90	M16x2	50	184	3710 kg	3.5 kg	
<b>TE24x2</b>	3000-5000-6000 kg	398	139	120	M24x3	60	246	8150 kg	7.8 kg	

 Dimensiones en mm. *Dimensions in mm.*

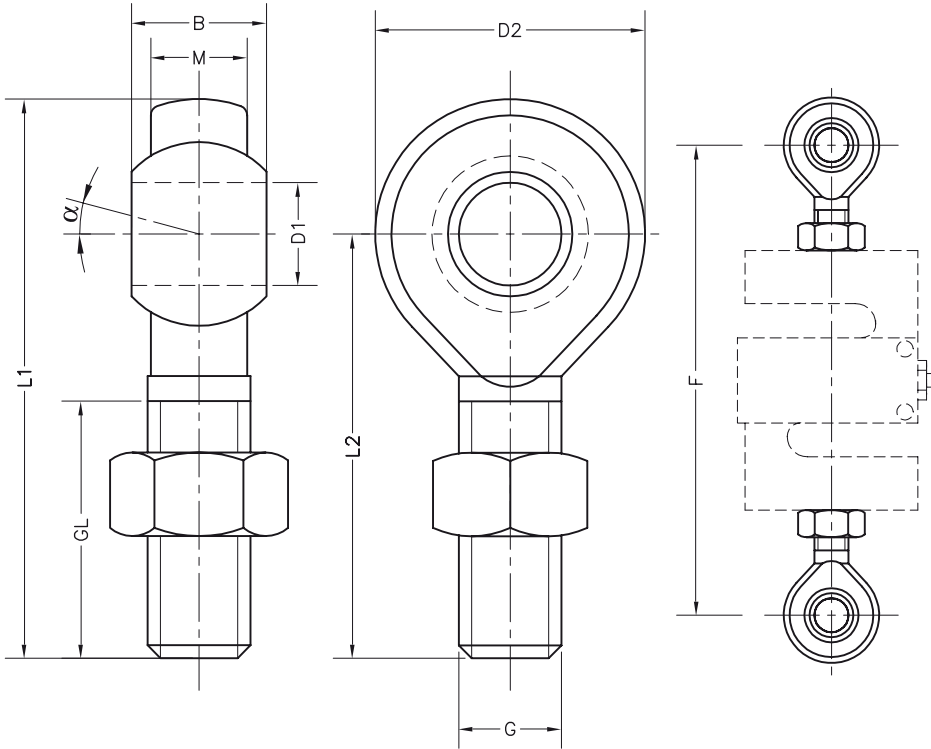
**ROTULAS PARA EL MODELO 620**  
**ROD ENDS FOR MODEL 620**

- **Material: Acero cincado**
- **Cada accesorio RO contiene un juego de: 2 rótulas y 2 tuercas**

- **Material: Steel zinc-plated**
- **Each accessory RO includes a set of: 2 rod ends and 2 nuts**

Dimensiones Accesorios RO/ RO Accessories Dimensions												
Accesorio Accessory	Capacidad/ Capacity (kg)	D2	B	M	D1	L1	L2	GL	G	$\alpha$	F	Peso transp. Trans. weight
<b>R012x1.75</b>	50...1000	32	16	12.0	Ø12	70	54	33	M12x1.75	13°	158	0.2 kg
<b>R016x2</b>	1500-2000	42	21	15	Ø16	87	66	40	M16x2	15°	184	0.7 kg
<b>R024x2</b>	3000-5000-6000	64	20	17	Ø25	126	94	53	M24x2	-	246	1.3 kg

Dimensiones en mm. *Dimensions in mm.*