

IMPAC IN 500 SERIES

Digital pyrometers with miniature sensor head for non-contact temperature measurement of non-metallic or coated metallic surfaces in ranges of -40 to 700°C (-40 to 1292°F).



The Impac® IN 510-N, IN 510, IN 520-N, and IN 520 are digital pyrometers for non-contact temperature measurement of non-metallic or coated metallic objects. The versions IN 510 and IN 520 are equipped with an illuminated LC display, which shows the actual temperature reading. All available parameters can be set via the integrated keyboard. The types IN 510-N and IN 520-N do not have display and keyboard, they are parametrized via interface.

All pyrometers are equipped with a stainless steel miniature sensor head, the field of view is 10:1 or 2:1 and they can be used in ambient temperatures up to 85°C or 180°C without cooling dependent on the type.

PRODUCT HIGHLIGHTS

- Sensor head and cable usable in ambient temperature up to 85 or 180°C without cooling
- Sensor head exchangeable without recalibration
- Close focus lens for small objects
- Switchable digital interface RS232 / RS485
- Isolated relays contact
- Selectable analog output
- Setting of parameters via keyboard or interface

AT A GLANCE

Temperature Ranges

-40 to 700°C (-40 to 1292°F)

Spectral Range

8 to 14 μm

Repeatability

0.5% oR in °C or 0.5°C

Optics

2 fixed optics
(FOV 2:1 or 10:1)

Output

0/4 to 20 mA, 0 to 5 V or
thermocouple J / K, RS232 / RS485
(switchable)

TECHNICAL DATA

Measurement Specifications	
Temperature Range	-40 to 700°C (-40 to 1292°F)
Sub Range	Adjustable; min. range 51°C
	Ex works preadjusted to 0 to 500°C (32 to 932°F)
Spectral Range	8 to 14 μm
Resolution	1/10°C (1/10°F, 1°F > 1000°F measuring temp.)
Emissivity ε	10 to 120% adjustable in steps of 0.1%
Measurement Uncertainty (ε = 1, t ₉₀ = 1 s, T _{amb} = 15 to 30°C)	0 to 700°C: 0.8% of reading in °C or 1°C ¹
	0 to -20°C: 2°C
	-20 to -40°C: 3°C
	T _K : 0.03% per °C or 0.05°C per °C (25°C) With thermocouple output: min. 2.5°C
Repeatability	0.5% of reading in °C or 0.5°C ¹
Optics	10:1 or 2:1

Electrical Specifications	
Power Supply	10 to 30 VDC, ripple < 0.5 V, current consumption max 60 mA
Load	Max 700 Ω at 24 V power supply (for current output) (500 Ω / 20 V)
Output Impedance	100 Ω (for thermocouple or voltage output)

Environmental Specifications	
Protection Class	IP 65 (converter, sensor head 10:1, IN 520-sensor head 2:1)
	IP 20 (IN 510-sensor head 2:1)
Max Ambient Temperature	Converter: 0 to 65°C (32 to 149°F)
	Sensor Head Types 510: 0 to 85°C (32 to 185°F)
	Sensor Head Types 520: 0 to 180°C (32 to 356°F)
Storage Temperature	Converter: -20 to 70°C (-4 to 158°F)
	Sensor Head: -20 to 85°C/180°C (-4 to 185°F/ 356°F)
Relative Humidity	10 to 95%, non-condensing
Weight	320 g (~0.71 lbs)
Housing	Converter: Aluminium
	Sensor head: Stainless steel

Interface and Communication	
Digital Interface	Switchable RS232/RS485
Analog Output	Linear current (0/4 to 20 mA), voltage (0 to 5 V) or thermocouple (type J or K)
Max/Min Value Storage	Clear time: OFF, 0.1 s, 0.25 s, 0.5 s, 1 s, 5 s, 25 s, extern, auto
Exposure Time t ₉₀	180 ms; switchable: 0.5 s, 1 s, 2 s, 5 s, 10 s, or 30 s
Output for Sensor Head Temp	10 mV/°C
Relays Contact	Isolated relays contact, 50 V DC, 0.2A; temperature and hysteresis adjustable
Temp Display (IN 510 / IN 520)	LCD, 4 digit, 3 values per second, display illumination permanent

¹ The larger value is valid. The sensor head must be in constant ambient temperature for at least 15 minutes.

² MB is a shortcut used for temperature range (in German: Messbereich).

The determination of the technical data of this pyrometer is carried out in accordance with VDI/VDE IEC TS 62942-2, the calibration / adjustment in accordance with VDI/VDE 3511, Part 4.4.

DIMENSIONS

Converter:

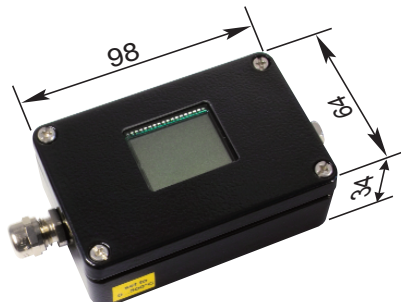

Sensor head:

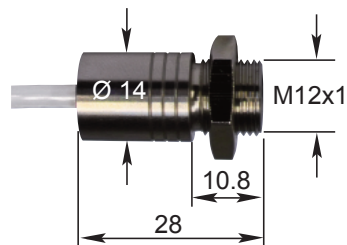

OPTICS

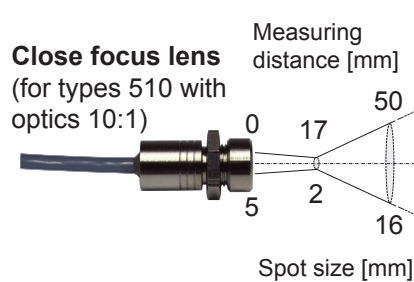
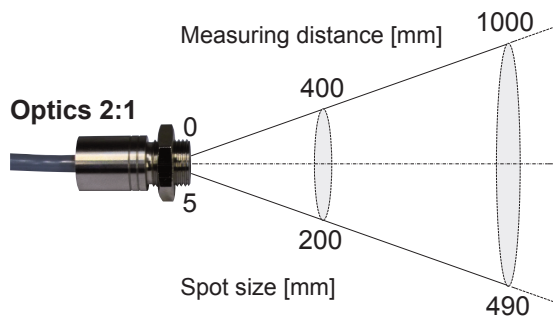
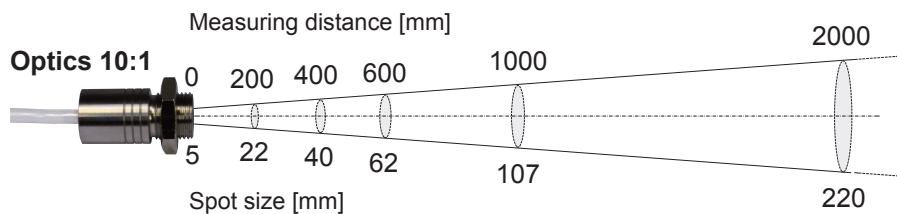

Dimensions in mm

REFERENCE NUMBERS

IN 500 Series				
Model	Head	Optics	Cable (3 m)	Cable (15 m)
IN 510-N	85°C head	Optics 2:1	3 874 160	3 874 170
		Optics 10:1	3 874 260	3 874 270
IN 510	85°C head	Optics 2:1	3 874 360	3 874 370
		Optics 10:1	3 874 460	3 874 470
IN 520-N	180°C head	Optics 2:1	3 874 180	3 874 190
		Optics 10:1	3 874 280	3 874 290
IN 520	180°C head	Optics 2:1	3 874 380	3 874 390
		Optics 10:1	3 874 480	3 874 490

ACCESSORIES

PN	Description
3 821 010	Connection cable (10 wire) 2 m, with additional digital cable (1 m)
3 821 020	Connecting cable 2 m for power supply and thermocouple output (compensating cable)
3 848 790	Close focus lens (only for 10:1 optics, max. 85°C ambient temperature, not in combination with air purge, cooling / purging unit or 90° mirror)
3 834 370	Fixed mounting angle (for sensor head or air purge with sensor head 10:1)
3 834 380	Adjustable mounting angle (for sensor head or air purge with sensor head 10:1)
3 835 330	Air purge (for sensor head 10:1)
3 835 410	Air purge (for sensor head 2:1)
3 834 260	Adjustable mounting angle (for air purge with sensor head 2:1)
3 835 340	90° mirror (only for sensor head 10:1)
3 890 560	DA 6000-N: LED digital display with digital input RS232 and possibility for pyrometer parameter settings
3 890 570	DA 6000-N digital display, to allow adjustment of pyrometer through RS485 interface
3 826 500	HT 6000: portable battery driven indicator and instrument for pyrometer parameter settings; RS232 / RS485
3 852 290	Power supply NG DC for DIN rail mounting; 100 to 240 VAC ⇒ 24 VDC, 1 A
3 852 440	Protocol transducer RS485/RS232 (switch.) ⇔ Profibus-DP for 1 device
3 852 460	Protocol transducer RS485 ⇔ Profibus DP for 32 devices



For international contact information, visit advancedenergy.com.

sales.support@aei.com
+1 970 221 0108



T-962 448 450 www.disai.net

PRECISION | POWER | PERFORMANCE

Specifications are subject to change without notice. Not responsible for errors or omissions. ©2020 Advanced Energy Industries, Inc. All rights reserved. Advanced Energy®, Impac®, and AE® are U.S. trademarks of Advanced Energy Industries, Inc.

