

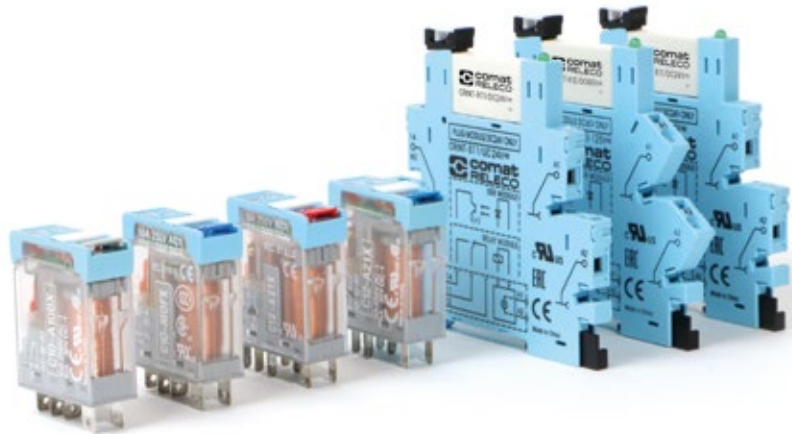















## 1.1 Interface Relays – IRC & CRINT



Application	Types	Pins	Contacts	AC ratings	DC ratings	Socket
<b>IRC – C10 Series</b>						
Interface standard relay	C10-A1x			10 A / 250 V	10 A / 30 V	S10
DC load switching	C10-G1x			10 A / 250 V	10 A / 30 V	S10
Low switching load	C10-T1xx			6 A / 250 V	6 A / 30 V	S10
Low switching load	C10-GTxx			6 A / 250 V	6 A / 30 V	S10
<b>IRC – C12 Series</b>						
Interface relay	C12-A2x			5 A / 250 V	5 A / 30 V	S12
Interface DC relay	C12-G2x			5 A / 250 V	5 A / 30 V	S12
<b>CRINT Series</b>						
High power contact AgSnO <sub>2</sub>	CRINT-C1x1			6 A / 250 V	6 A / 30 V	
Low power contact AgSnO <sub>2</sub> + 3μ Au	CRINT-C1x2			6 A / 250 V	6 A / 30 V	
DC solid state switch	CRINT-C1x5				2 A / 24 V	
AC solid state switch	CRINT-C1x8			1 A / 240 V		

<b>Type</b>	<b>C10-A1x/ ... V</b> Standard relay, 1 change-over contact Contact Ag Sn O2 to high inrush		
<b>Maximum contact load</b>	<b>10 A/250 V AC-1</b>	<b>0,5 A/110 V DC-1</b>	
	<b>10 A/30 V DC-1</b>	<b>0,2 A/220 V DC-1</b>	
	<b>13 A/250 V AC-1</b>	<b>5A<sub>US</sub></b>	
<b>Recommended minimum contact load</b>	<b>10 mA/10 V Code 0,5</b>		
	<b>5 mA/5 V Code 8</b>		

<b>Contacts</b>			
Material	Standard	Code 0	AgNi
	Optional	Code 8	AgNi+ 3 μ Au
	Optional	Code 5	Ag Sn O2
Rated current			10 A
Switch-on current max. (20 ms)			30 A (120 A for code 5)
Switching voltage max.			250 V
AC load (Fig 1)			2,5 kVA
DC load			see fig. 2

<b>Coil</b>	
Coil resistance	see table; tolerance ± 10 %
Pick-up voltage	≤ 0,8 x U <sub>N</sub>
Release voltage	≥ 0,1 x U <sub>N</sub>
Nominal power	1,1 VA (AC)/0,7 W (DC)

<b>Coil table</b>					
VAC	Ω	mA	VDC	Ω	mA
24	290	45	12	224	53
48	1200	23	24	742	32
115	7.300	9,5	48	3.500	13,7
230	28.800	4,7	110	19.900	5,5

<b>Insulation</b>	Volt rms, 1 min
Contact open	1000 V
Contact/coil	5 kV
Insulation resistance at 500 V	≥1 GΩ
Insulation, IEC 61810-1	4 kV/3

<b>Specifications</b>	
Ambient temperature operation/storage	-40 (no ice)...70 °C / -40 ... 80 °C
Pick-up time/bounce time	10 ms/ ≤ 1 ms
Release time/bounce time	5 ms/ ≤ 3 ms
Mechanical life ops	AC: 10 Mill./DC: 20 Mill.
DC voltage endurance at rated load	≥100000 switching cycles
Switching frequency at rated load	≤ 1200/h
Protection class	IP40
Weight	21 g

<b>Standard types</b>			
<b>VAC 50 Hz/60 Hz: 24, 48, 115 (120), 230 (240)</b>	<b>C10-A10/AC...V</b>	<b>C10-A18/AC...V</b>	<b>C10-A15/AC...V</b>
<b>LED</b>	<b>C10-A10X/AC...V</b>	<b>C10-A18X/AC...V</b>	<b>C10-A15X/AC...V</b>
<b>RC suppressor</b>	<b>C10-A10R/AC...V</b>	<b>C10-A18R/AC...V</b>	<b>C10-A15R/AC...V</b>
<b>VDC 12, 24, 48, 110</b>	<b>C10-A10/DC...V</b>	<b>C10-A18/DC...V</b>	<b>C10-A15/DC...V</b>
<b>LED</b>	<b>C10-A10X/DC...V</b>	<b>C10-A18X/DC...V</b>	<b>C10-A15X/DC...V</b>
<b>Polarity and free wheeling diode</b>	<b>C10-A10FX/DC...V</b>	<b>C10-A18FX/DC...V</b>	<b>C10-A15FX/DC...V</b>
<b>VAC/DC bridge rectifier 24 V, 48 V</b>	<b>C10-A10BX/UC...V</b>	<b>C10-A18BX/UC...V</b>	<b>C10-A15BX/UC...V</b>

"..." Enter the voltage for full type designation

<b>Accessories</b>	
Socket:	<b>S10, S10-M, S10-P</b>



**Connection diagram**

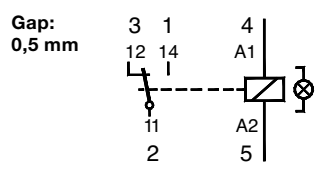

**Fig. 1 AC voltage endurance**

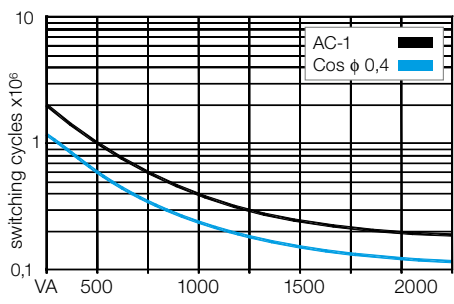

**Fig. 2 DC load limit curve**

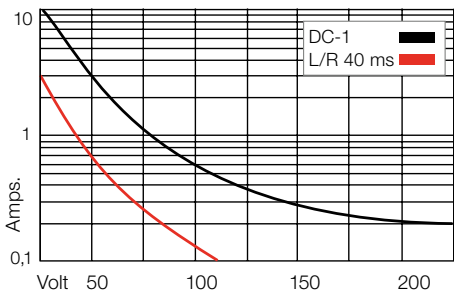

**Dimensions [mm]**

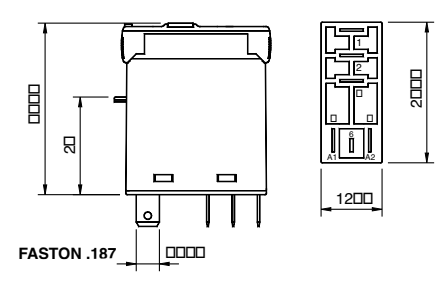

**Technical approvals, conformities**



IEC 61810; EN 60947



<b>Type</b>	<b>C10-G1X/ ... V</b> Standard relay 1 open contact for high DC load Contact Ag Sn O2 to high inrush
-------------	---

<b>Maximum contact load</b>	<b>10 A/250 V AC-1</b> <b>0,8 A/110 V DC-1</b> <b>10 A/30 V DC-1</b> <b>0,4 A/220 V DC-1</b>
<b>Recommended minimum contact load</b>	<b>10 mA/10 V Code 0,5</b> <b>5 mA/5 V Code 8</b>

<b>Contacts</b>			
Material	Standard	Code 0	AgNi
	Optional	Code 8	AgNi +3 μ Au
	Optional	Code 5	Ag SnO2
Rated current	10 A		
Switch-on current max. (20 ms)	30 A (120 A for code 5)		
Switching voltage max.	250 V		
AC load (Fig 1)	2,5 kVA		
DC load	see Fig. 2		

<b>Coil</b>			
Coil resistance	see table; tolerance ± 10 %		
Pick-up voltage	≤ 0,8 x U <sub>N</sub>		
Release voltage	≥ 0,1 x U <sub>N</sub>		
Nominal power	1,1 VA (AC)/0,7 W (DC)		

<b>Coil table</b>					
VAC	Ω	mA	VDC	Ω	mA
24	290	45	12	224	53
48	1200	23	24	742	32
115	7.300	9,5	48	3.500	13,7
230	28.800	4,7	110	19.900	5,5

<b>Insulation</b>	Volt rms, 1 min
Contact open	2000 V
Contact/coil	5 kV
Insulation resistance at 500 V	≥ 1 GΩ
Insulation, IEC 61810-1	4 kV/3

<b>Specifications</b>	
Ambient temperature operation/storage	-40 (no ice)...70 °C /-40 ... 80 °C
Pick-up time/bounce time	10 ms/≤ 1 ms
Release time/bounce time	8 ms
Mechanical life ops	AC: 10 Mill./DC: 20 Mill.
DC voltage endurance at rated load	≥ 100000 switching cycles
Switching frequency at rated load	≤ 1200/h
Protection class	IP40
Weight	21 g

<b>Standard types</b>		
<b>VAC 50 Hz/60 Hz: 24, 48, 115 (120), 230 (240)</b>	<b>C10-G10/AC ... V</b>	<b>C10-G15/AC ... V</b>
<b>LED</b>	<b>C10-G10X/AC ... V</b>	<b>C10-G15X/AC ... V</b>
<b>RC suppressor</b>	<b>C10-G10R/AC...V</b>	<b>C10-G15R/AC...V</b>
<b>VDC 12, 24, 48, 110</b>	<b>C10-G10/DC ... V</b>	<b>C10-G15/DC ... V</b>
<b>LED</b>	<b>C10-G10X/DC ... V</b>	<b>C10-G15X/DC ... V</b>
<b>Polarity and free wheeling diode</b>	<b>C10-G10FX/DC ... V</b>	<b>C10-G15FX/DC... V</b>
<b>AC/DC bridge rectifier 24 V, 48 V</b>	<b>C10-G10BX/DC ... V</b>	<b>C10-G15BX/UC... V</b>

"..." Enter the voltage for full type designation

<b>Accessories</b>	
Socket:	<b>S10, S10-M, S10-P</b>

**Connection diagram**

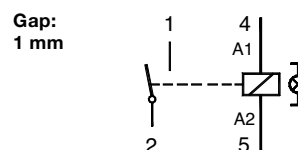

**Fig. 1 AC voltage endurance**

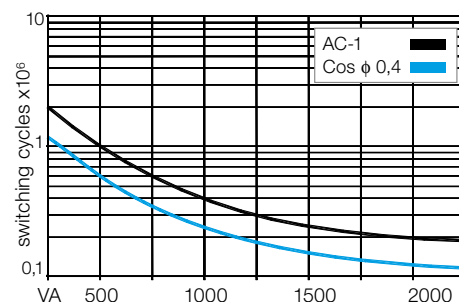

**Fig. 2 DC load limit curve**

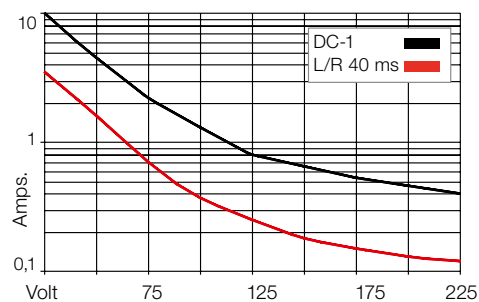

**Dimensions [mm]**

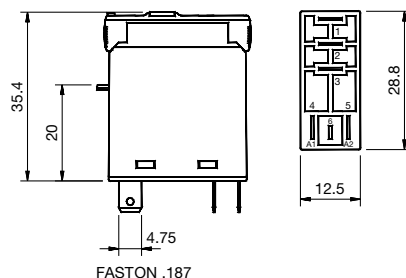

**Technical approvals, conformities**



IEC 61810; EN 60947

<b>Type</b>	<b>C10-T1x/ ... V</b> Standard relay for low power application			
<b>Maximum contact load</b>	<b>6 A/250 V AC-1</b>	<b>0,5 A/110 V DC-1</b>		
	<b>6 A/30 V DC-1</b>	<b>0,2 A/220 V DC-1</b>		
<b>Recommended minimum contact load</b>	<b>5 mA/5 V Code 1</b>			
	<b>1 mA/5 V Code 3</b>			

<b>Contacts</b>			
Material	Standard	Code 1	AgNi + 0,2 μ Au
	Optional	Code 3	AgNi + 3 μ Au
Rated current	6 A		
Switch-on current max. (20 ms)	15 A		
Switching voltage max	250 V		
AC load (Fig 1)	1,5 kVA		
DC load	see fig. 2		

<b>Coil</b>	
Coil resistance	see table; tolerance ± 10 %
Pick-up voltage	≤ 0,8 × U <sub>N</sub>
Release voltage	≥ 0,1 × U <sub>N</sub>
Nominal power	1,1 VA (AC)/0,7 W (DC)

<b>Coil table</b>																															
	<table border="1"> <thead> <tr> <th>VAC</th> <th>Ω</th> <th>mA</th> <th>VDC</th> <th>Ω</th> <th>mA</th> </tr> </thead> <tbody> <tr> <td>24</td> <td>290</td> <td>45</td> <td>12</td> <td>224</td> <td>53</td> </tr> <tr> <td>48</td> <td>1200</td> <td>23</td> <td>24</td> <td>742</td> <td>32</td> </tr> <tr> <td>115</td> <td>7.300</td> <td>9,5</td> <td>48</td> <td>3.500</td> <td>13,7</td> </tr> <tr> <td>230</td> <td>28.800</td> <td>4,7</td> <td>110</td> <td>19.900</td> <td>5,5</td> </tr> </tbody> </table>	VAC	Ω	mA	VDC	Ω	mA	24	290	45	12	224	53	48	1200	23	24	742	32	115	7.300	9,5	48	3.500	13,7	230	28.800	4,7	110	19.900	5,5
VAC	Ω	mA	VDC	Ω	mA																										
24	290	45	12	224	53																										
48	1200	23	24	742	32																										
115	7.300	9,5	48	3.500	13,7																										
230	28.800	4,7	110	19.900	5,5																										

<b>Insulation</b>	Volt rms, 1 min
Contact open	1000 V
Contact/coil	5 kV
Insulation resistance at 500 V	≥ 1 GΩ
Insulation, IEC 61810-1	4 kV/3

<b>Specifications</b>	
Ambient temperature operation/storage	-40 (no ice)...70 °C / -40 ... 80 °C
Pick-up time/bounce time	10 ms/≤ 1 ms
Release time/bounce time	5 ms/≤ 3 ms
Mechanical life ops	AC: 10 Mill./DC: 20 Mill.
DC voltage endurance at rated load	≥ 100000 switching cycles
Switching frequency at rated load	1200/h
Protection class	IP40
Weight	21 g

<b>Standard types</b>		
<b>VAC 50 Hz/60 Hz: 24, 48, 115 (120), 230 (240)</b>	<b>C10-T11/AC ... V</b>	<b>C10-T13/AC ... V</b>
<b>LED</b>	<b>C10-T11X/AC ... V</b>	<b>C10-T13X/AC ... V</b>
<b>RC suppresor</b>	<b>C10-T11R/AC...V</b>	<b>C10-T13R/AC...V</b>
<b>VDC12, 24, 48, 110</b>	<b>C10-T11/DC ... V</b>	<b>C10-T13/DC ... V</b>
<b>LED</b>	<b>C10-T11X/DC ... V</b>	<b>C10-T13X/DC ... V</b>
<b>Polarity and free wheeling diode</b>	<b>C10-T11FX/DC ... V</b>	<b>C10-T13FX/DC ... V</b>
<b>AC/DC bridge rectifier 24 V, 48 V</b>	<b>C10-T11BX/UC ... V</b>	<b>C10-T13BX/UC ... V</b>

"..." Enter the voltage for full type designation

<b>Accessories</b>	
Socket:	<b>S10, S10-P</b>



**Connection diagram**

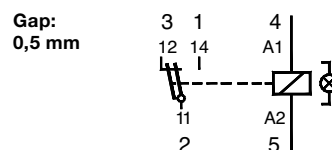

**Fig. 1 AC voltage endurance**

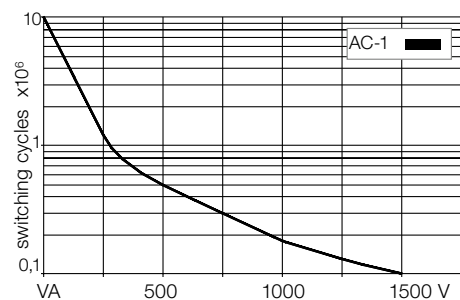

**Fig. 2 DC load limit curve**

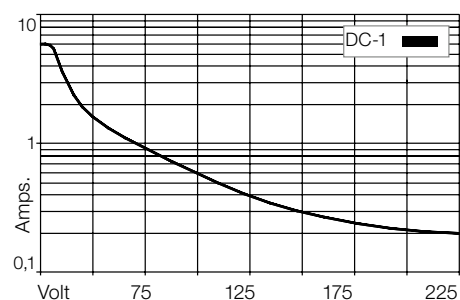

**Dimensions [mm]**

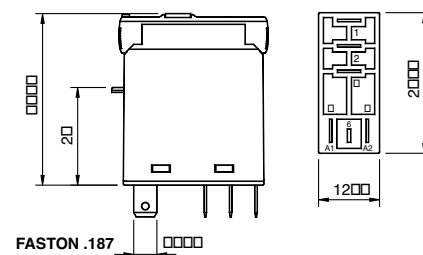

**Technical approvals, conformities**



IEC 61810; EN 60947

<b>Type</b>	<b>C12-A2x/ ... V</b> Standard relay 2 change-over contact		
<b>Maximum contact load</b>	<b>5 A/250 V AC-1</b>	<b>0,5 A/110 V DC-1</b>	
	<b>5 A/30 V DC-1</b>	<b>0,2 A/220 V DC-1</b>	
<b>Recommended minimum contact load</b>	<b>10 mA/10 V Code 1</b>		
	<b>5 mA/5 V Code 2</b>		

<b>Contacts</b>			
Material	Standard	Code 1	AgNi + 0,2 μ Au
	Optional	Code 2	AgNi + 3 μ Au
Rated current	5 A		
Switch-on current max. (20 ms)	15 A		
Switching voltage max.	250 V		
AC load (Fig 1)	1,2 kVA		
DC load	see fig. 2		

<b>Coil</b>			
Coil resistance	see table; tolerance ± 10 %		
Pick-up voltage	≤ 0,8 × U <sub>N</sub>		
Release voltage	≥ 0,1 × U <sub>N</sub>		
Nominal power	1,1 VA (AC)/0,7 W (DC)		

<b>Coil table</b>					
VAC	Ω	mA	VDC	Ω	mA
24	290	45	12	224	53
48	1200	23	24	742	32
115	7.300	9,5	48	3.500	13,7
230	28.800	4,7	110	19.900	5,5

<b>Insulation</b>	Volt rms, 1 min
Contact open	1000 V
Contact/contact	3000 V
Contact/coil	5 kV
Insulation resistance at 500 V	≥1 GΩ
Insulation, IEC 61810-1	4 kV/3

<b>Specifications</b>	
Ambient temperature operation/storage	-40 (no ice)...60 °C /-40 ... 80 °C
Pick-up time/bounce time	10 ms/≤ 1 ms
Release time/bounce time	5 ms/≤ 3 ms
Mechanical life ops	AC: 10 Mill./DC: 20 Mill.
DC voltage endurance at rated load	≥100000 switching cycles
Switching frequency at rated load	≤ 1200/h
Protection class	IP40
Weight	21 g

<b>Standard types</b>		
VAC 50 Hz/60 Hz: 24, 48, 115 (120), 230 (240)	<b>C12-A21/AC ... V</b>	<b>C12-A22/AC ... V</b>
LED	<b>C12-A21X/AC ... V</b>	<b>C12-A22X/AC ... V</b>
RC suppressor	<b>C12-A21R/AC ... V</b>	<b>C12-A22R/AC ... V</b>
VDC 12, 24, 48, 110	<b>C12-A21/DC ... V</b>	<b>C12-A22/DC ... V</b>
LED	<b>C12-A21X/DC ... V</b>	<b>C12-A22X/DC ... V</b>
Polarity and free wheeling diode	<b>C12-A21FX/DC ... V</b>	<b>C12-A22FX/DC ... V</b>
AC/DC bridge rectifier 24 V, 48 V	<b>C12-A21BX/UC ... V</b>	<b>C12-A22BX/UC ... V</b>

"..." Enter the voltage for full type designation

<b>Accessories</b>	
Socket:	<b>S12, S12-P</b>



**Connection diagram**

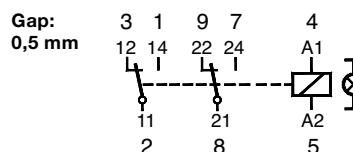

**Fig. 1 AC voltage endurance**

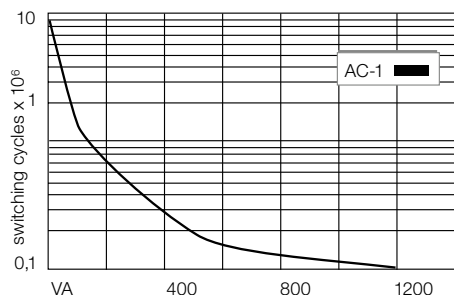

**Fig. 2 DC load limit curve**

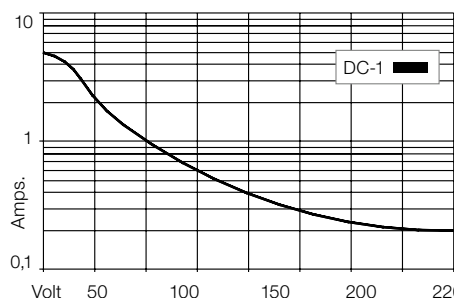

**Dimensions [mm]**

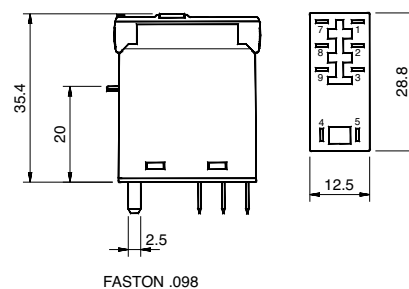

**Technical approvals, conformities**



IEC 61810; EN 60947



<b>Type</b>	<b>C12-G2x/ ... V</b> Standard relay 2 open contacts			
-------------	--	--	--	--

<b>Maximum contact load</b>	<b>5 A/250 V AC-1</b>	<b>0,8 A/110 V DC-1</b>
	<b>5 A/30 V DC-1</b>	<b>0,4 A/220 V DC-1</b>

<b>Recommended minimum contact load</b>	<b>10 mA/10 V Code 1</b>
	<b>5 mA/5 V Code 2</b>

**Contacts**

Material	Standard	Code 1	AgNi + 0,2 μ Au
	Optional	Code 2	AgNi + 3 μ Au
Rated current	5 A		
Switch-on current max. (20 ms)	15 A		
Switching voltage max.	250 V		
AC load (Fig 1)	1,2 kVA		
DC load	see Fig. 2		

**Coil**

Coil resistance	see table; tolerance ± 10 %
Pick-up voltage	≥ 0,8 x U <sub>N</sub>
Release voltage	≥ 0,1 x U <sub>N</sub>
Nominal power	1,1 VA (AC)/0,7 W (DC)

**Coil table**

VAC	Ω	mA	VDC	Ω	mA
24	290	45	12	224	53
48	1200	23	24	742	32
115	7.300	9,5	48	3.500	13,7
230	28.800	4,7	110	19.900	5,5

**Insulation**

	Volt rms, 1 min
Contact open	2000 V
Contact/contact	3000 V
Contact/coil	5 kV
Insulation resistance at 500 V	≥ 1 GΩ
Insulation, IEC 61810-1	4 kV/3

**Specifications**

Ambient temperature operation/storage	-40 (no ice)...60 °C /-40 ... 80 °C
Pick-up time/bounce time	10 ms/≤ 1 ms
Release time/bounce time	5 ms/≤ 3 ms
Mechanical life ops	AC: 10 Mill./DC: 20 Mill.
DC voltage endurance at rated load	≥ 100000 switching cycles
Switching frequency at rated load	≤ 1200/h
Protection class	IP40
Weight	21 g

**Standard types**

VAC 50 Hz/60 Hz: 24, 48, 115, (120), 230, (240)

LED

RC suppressor

VDC 12, 24, 48, 110

LED

Polarity and free wheeling diode

AC/DC bridge rectifier 24 V, 48 V

**C12-G21/AC ... V**

**C12-G21X/AC ... V**

**C12-G21R/AC ... V**

**C12-G21/DC ... V**

**C12G21X/DC ... V**

**C12-G21FX/DC ... V**

**C12-G21BX/UC ... V**

**C12-G22/AC ... V**

**C12-G22X/AC ... V**

**C12-G22R/AC ... V**

**C12-G22/DC ... V**

**C12-G22X/DC ... V**

**C12-G22FX/DC ... V**

**C12-G22BX/UC ... V**

**Connection diagram**

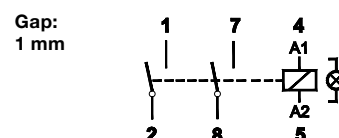

**Fig. 1 AC voltage endurance**

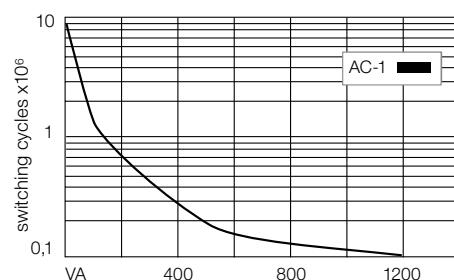

**Fig. 2 DC load limit curve**

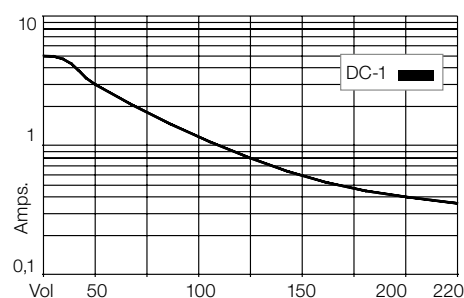

**Dimensions [mm]**

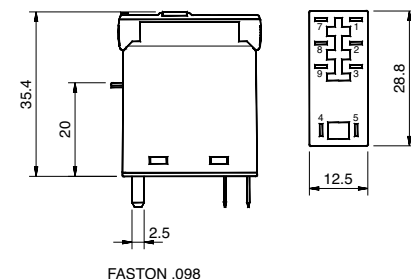

**Technical approvals, conformities**



IEC 61810; EN 60947

"..." Enter the voltage for full type designation

**Accessories**

Socket: **S12, S12-P**



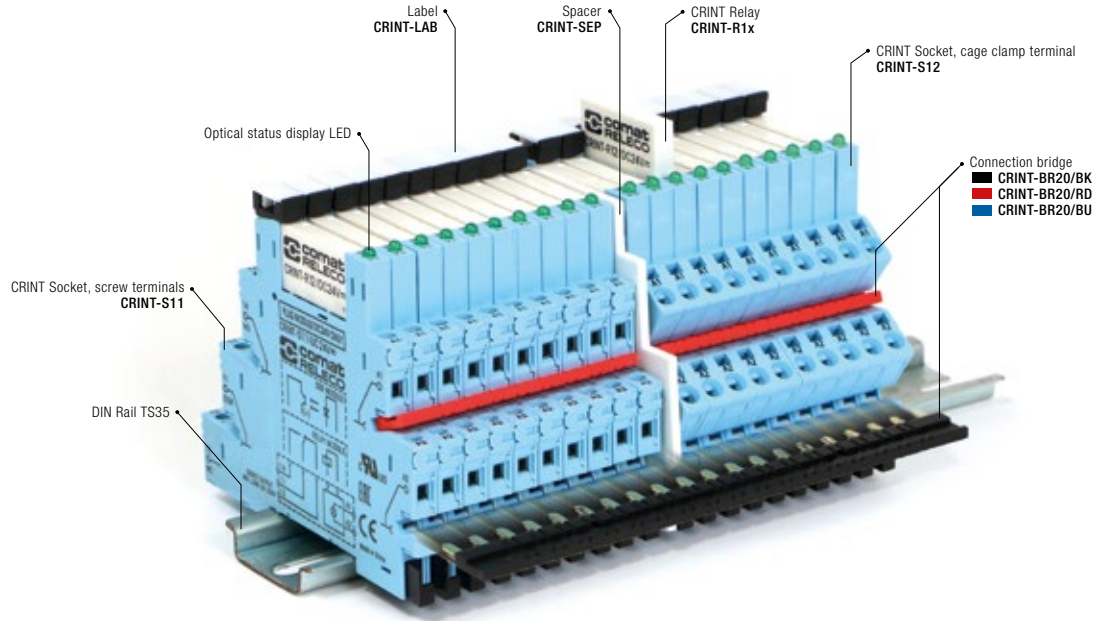

**CRINT RELAY CODIFICATION AND ACCESSORIES**

**CRINT INTERFACE RELAY CONSISTS OF TWO COMPONENTS.**

- RELAY
- SOCKET

**CODIFICATION FOR COMPLETE RELAY MODULE RELAY AND SOCKET 6,2 MM**

1		2	3	4	5	6	7	8
<b>CRINT</b>	<b>-</b>	<b>C</b>	<b>1</b>	<b>1</b>	<b>1</b>	<b>R</b>	<b>/</b>	<b>UC 24V</b>

**1. Product family**  
CRINT

**2. Type**  
C = Combined version (Socket and Relay)

**3. Contact**  
1 = One change-over contact

**4. Connection type**  
1 = Screw terminal  
2 = Cage clamp terminal

**5. Output**  
1 = AgSnO<sub>2</sub>  
2 = AgSnO<sub>2</sub> + 3μ Au  
5 = NO / Solid-state DC  
8 = NO / Solid-state AC

**6. Options**  
- = Standard version  
R = Railway version

**7. Supply voltage**  
UC = AC/DC  
DC = Only for C1x5 and C1x8

**8. Nominal voltage**  
12V, 24V, 48V, 60V, 110-125V, 220-240V

**RELAY CODIFICATION**

1		2	3	4	5
<b>CRINT</b>	<b>-</b>	<b>R</b>	<b>11</b>	<b>DC</b>	<b>12V</b>

**1. Product family**  
CRINT

**2. Type**  
R = Relay

**3. Contact**  
11 = AgSnO<sub>2</sub>  
12 = AgSnO<sub>2</sub> + 3μ Au  
15 = NO / Solid-state DC  
18 = NO / Solid-state AC

**4. Supply voltage**  
DC

**5. Nominal voltage**  
12V, 24V, 48V, 60V\*

\*60V Relay used for all sockets with a nominal voltage higher or equal 60V

**Dimensions [mm]**

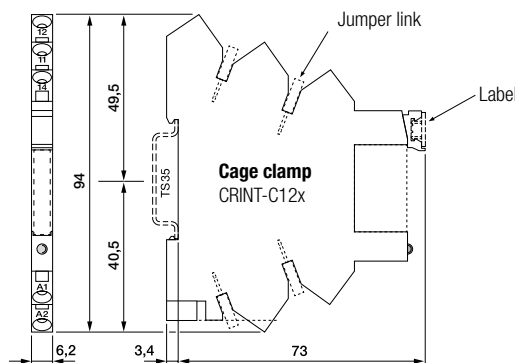
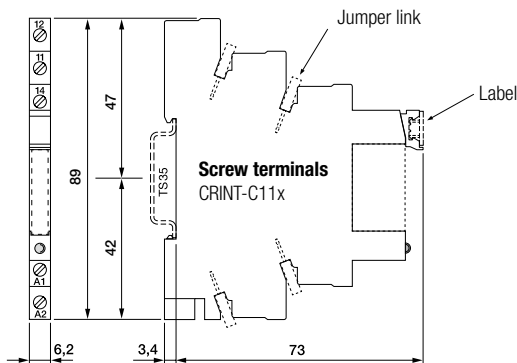

# CRINT 1x1 series

## Interface module with mechanical CO output contact

### DIN Rail mounting according to DIN 43 880

#### Types: CRINT-C111, CRINT-C121 / ...V

For PLC's and process control. High power contact AgSnO<sub>2</sub>.  
With screw terminals (CRINT-S11) or cage clamp terminals (CRINT-S12).  
Recommended max. load 250 V 6 A resistive.

**Max. contact load** **6 A, 250 V AC-1** **6 A, 30 V DC-1**

#### Contact

Type	1 CO
Material	AgSnO <sub>2</sub>
Switching current   <sub>TH</sub>	6 A 250 V AC
Recommended minimal load	100 mA / 12 V
Switching power DC-1 30 V	180 W
Switching power AC-1 230 V	1500 VA
Switching power AC-15 230 V	300 VA
Peak inrush current	15 A/2.5 ms

#### Coil

Operation voltage AC 50/60 Hz / DC	0.8 ... 1.25 U <sub>N</sub>
Nominal power DC/AC	408 / 900 mW

#### Insulation

Test voltage I / O	6 kVrms 1 minute
Pollution degree	3
Over voltage category	III
Open contact	1000 Vrms dielectric strength 1 min
Standard	EN61810-5

#### General Specifications

Ambient temperature: operation / storage	-40 ... +70 °C / -40 ... +85 °C
Typical response time @ V <sub>n</sub>	7 ms
Typical release time @ V <sub>n</sub>	15 ms
Switching cycles: mech./elec.	10 x 10 <sup>6</sup> / 3 x 10 <sup>4</sup>
Cond. cross section screw terminal	2.5 mm <sup>2</sup>
Cond. cross section spring cage	0.75 ... 2.5 mm <sup>2</sup>
Ingress protection	IP 20
Mounting position	any
Housing material	Polyamide PA6

#### Order information

Screw terminal: **CRINT-C111/UC...V**

**UC12V**  
**UC24V**  
**UC48V**  
**UC60V**  
**UC110-125V**  
**UC220-240V**

Cage clamp terminal: **CRINT-C121/UC...V**

„ ...“ enter the voltage for full type designation

#### Accessories

Jumper link (5 pcs):  
blue: **CRINT-BR20-BU/5**  
red: **CRINT-BR20-RD/5**  
black: **CRINT-BR20-BK/5**

Label plate (64 pcs): **CRINT-LAB/64**  
Spacer (5 pcs): **CRINT-SEP/5**

Replacement relays:  
**CRINT-R11/DC...V**  
„ ...“ enter the voltage for full type designation

**DC12V**  
**DC24V**  
**DC48V**  
**DC60V\***

\*60V Relay used for all sockets with a nominal voltage higher or equal 60V



#### Connection diagram

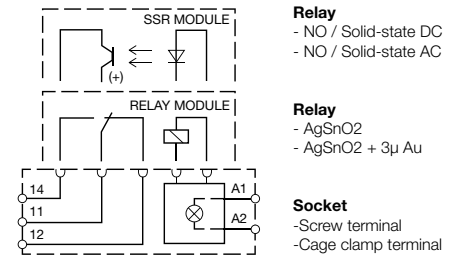

#### Fig.1 AC voltage endurance

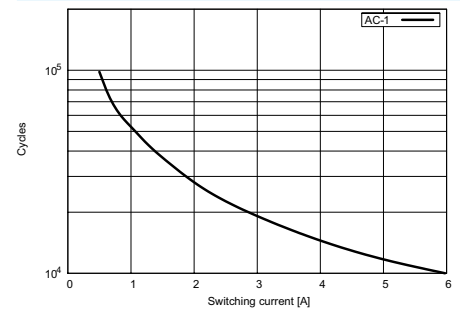

#### Fig. 2 DC load limit curve

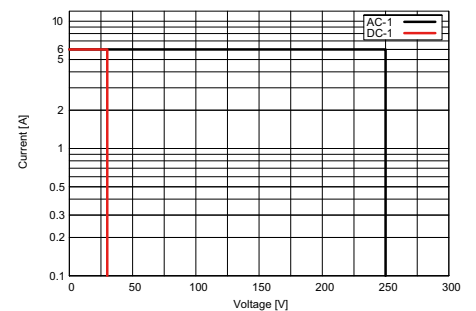

#### Dimensions p.72

#### Technical approvals, conformities





# CRINT 1x2 series

## Interface module with mechanical CO output contact

### DIN Rail mounting according to DIN 43 880



#### Types: CRINT-C112, CRINT-C122 / ...V

Specially for PLC, process controls with DC currents. Contact  $\text{AgSnO}_2 + 3\mu\text{Au}$ . For low power application. With screw terminals (CRINT-S11) or cage clamp terminals (CRINT-S12). No external freewheeling circuit required.

<b>Max. contact load</b>	<b>6 A, 250 V AC-1</b>	<b>6 A, 30 V DC-1</b>
<b>Contact</b>		
Type	1 CO	
Material	$\text{AgSnO}_2 + 3\mu\text{Au}$	
Switching current   <sub>TH</sub>	6 A 250 V AC	
Recommended minimal load	10 mA / 6 V	
Switching power DC-1 30 V	180 W	
Switching power AC-1 230 V	1500 VA	
Switching power AC-15 230 V	300 VA	
Peak inrush current	15 A/2.5 ms	

<b>Coil</b>		
Operation voltage AC 50/60 Hz / DC	0.8 ... 1.25 U <sub>N</sub>	
Nominal power DC/AC	408 / 900 mW	

<b>Insulation</b>		
Test voltage I / O	6 kVrms 1 minute	
Pollution degree	3	
Over voltage category	III	
Open contact	1000 Vrms dielectric strength 1 min	
Standard	EN61810-5	

<b>General Specifications</b>		
Ambient temperature: operation / storage	-40 ... +70 °C / -40 ... +85 °C	
Typical response time @ V <sub>n</sub>	7 ms	
Typical release time @ V <sub>n</sub>	15 ms	
Switching cycles: mech./elec.	10 x 10 <sup>6</sup> / 3 x 10 <sup>4</sup>	
Cond. cross section screw terminal	2.5 mm <sup>2</sup>	
Cond. cross section spring cage	0.75 ... 2.5 mm <sup>2</sup>	
Ingress protection	IP 20	
Mounting position	any	
Housing material	Polyamide PA6	

<b>Order information</b>		
Screw terminal:	<b>CRINT-C112/UC...V</b>	<b>UC12V UC24V UC48V UC60V UC110-125V UC220-240V</b>
Cage clamp terminal:	<b>CRINT-C122/UC...V</b>	
„ ...“ enter the voltage for full type designation		

<b>Accessories</b>		
Jumper link (5 pcs):	blue:	<b>CRINT-BR20-BU/5</b>
	red:	<b>CRINT-BR20-RD/5</b>
	black:	<b>CRINT-BR20-BK/5</b>
Label plate (64 pcs):	<b>CRINT-LAB/64</b>	
Spacer (5 pcs):	<b>CRINT-SEP/5</b>	
Replacement relays:	<b>DC12V DC24V DC48V DC60V*</b>	
„ ...“ enter the voltage for full type designation		

\*60V Relay used for all sockets with a nominal voltage higher or equal 60V



#### Connection diagram

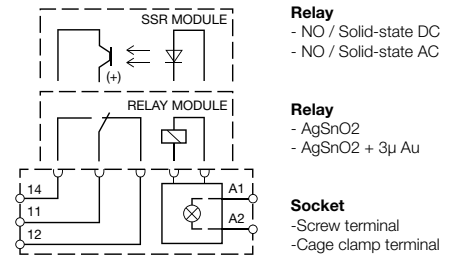

**Fig.1 AC voltage endurance**

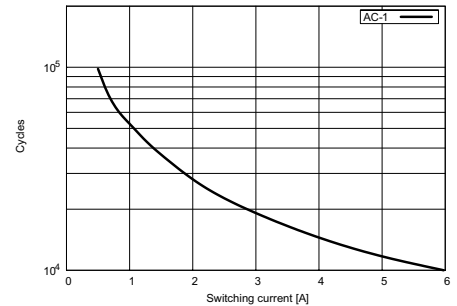

**Fig. 2 DC load limit curve**

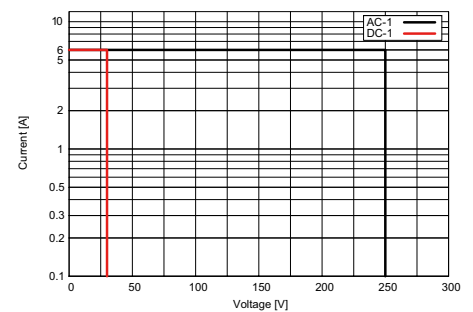

#### Dimensions p.72

#### Technical approvals, conformities



# CRINT 1x5 series

Solid state interface module with mechanical NO output contact

DIN Rail mounting according to DIN 43 880

**Types: CRINT-C115, CRINT-C125 / ...V**

For PLC's and process control. DC solid state switch, type NO.  
For fast and high frequent switching. With screw terminals (CRINT-S11) or cage clamp terminals (CRINT-S12).

<b>Max. contact load</b>	<b>2 A, 24 V DC-1</b>
<b>Contact</b>	
Type	1 NO (Solid state DC)
Material	MOSFET
Switching current   <sub>TH</sub>	2 A 24 V DC
Recommended minimal load	20 mA / 5 V
Peak inrush current	48 A/10 ms
<b>Coil</b>	
Operation voltage AC 50/60 Hz / DC	0.8 ... 1.25 U <sub>N</sub>
Nominal power DC/AC	160 / — mW
<b>Insulation</b>	
Test voltage I / O	2.5 kVrms 1 minute
Pollution degree	3
Over voltage category	III
Open contact	1000 Vrms dielectric strength 1 min
Standard	EN61810-5
<b>General Specifications</b>	
Ambient temperature: operation / storage	-30 ... +70 °C / -40 ... +85 °C
Typical response time @ V <sub>n</sub>	1 ms
Typical release time @ V <sub>n</sub>	1 ms
Cond. cross section screw terminal	2.5 mm <sup>2</sup>
Cond. cross section spring cage	0.75 ... 2.5 mm <sup>2</sup>
Ingress protection	IP 20
Mounting position	any
Housing material	Polyamide PA6

**Order information**

Screw terminal:	<b>CRINT-C115/UC...V</b>	<b>UC12V</b> <b>UC24V</b> <b>UC48V</b>
Cage clamp terminal:	<b>CRINT-C125/UC...V</b>	<b>UC60V</b> <b>UC110-125V</b> <b>UC220-240V</b>
„ ...“ enter the voltage for full type designation		

**Accessories**

Jumper link (5 pcs):	blue:	<b>CRINT-BR20-BU/5</b>
	red:	<b>CRINT-BR20-RD/5</b>
	black:	<b>CRINT-BR20-BK/5</b>

Label plate (64 pcs):	<b>CRINT-LAB/64</b>
Spacer (5 pcs):	<b>CRINT-SEP/5</b>

Replacement relays:	<b>DC12V</b> <b>DC24V</b> <b>DC48V</b> <b>DC60V*</b>
„ ...“ enter the voltage for full type designation	

\*60V Relay used for all sockets with a nominal voltage higher or equal 60V



**Connection diagram**

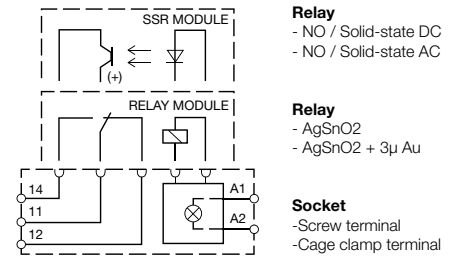

**Output derating curve**

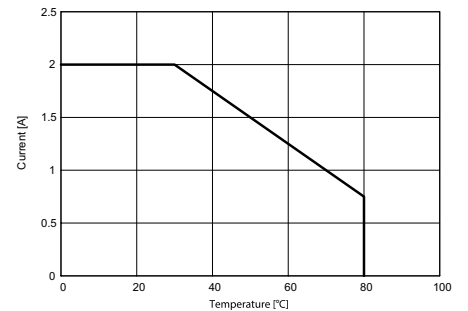

**Dimensions p.72**

**Technical approvals, conformities**



# CRINT 1x8 series

Solid state interface module with mechanical NO output contact

DIN Rail mounting according to DIN 43 880



**Types: CRINT-C118, CRINT-C128 / ...V**

For PLC's and process control.

AC output interface zero synchronous switching NO for resistive or similar load. (No transformer rec.) With screw terminals (CRINT-S11) or cage clamp terminals (CRINT-S12).

**Max. contact load** **1 A, 240 V AC-1**

**Contact**

Type	1 NO (Solid state AC)
Material	TRIAC
Switching current   <sub>TH</sub>	1 A 240 V AC
Recommended minimal load	22 mA / 12 V
Peak inrush current	80 A/10 ms

**Coil**

Operation voltage AC 50/60 Hz / DC	0.8 ... 1.25 U <sub>N</sub>
Nominal power DC/AC	150 / — mW

**Insulation**

Test voltage I / O	2.5 kVrms 1 minute
Pollution degree	3
Over voltage category	III
Open contact	1000 Vrms dielectric strength 1 min
Standard	EN61810-5

**General Specifications**

Ambient temperature: operation / storage	-30 ... +70 °C / -40 ... +85 °C
Typical response time @ V <sub>n</sub>	1 ms
Typical release time @ V <sub>n</sub>	1 ms
Cond. cross section screw terminal	2.5 mm <sup>2</sup>
Cond. cross section spring cage	0.75 ... 2.5 mm <sup>2</sup>
Ingress protection	IP 20
Mounting position	any
Housing material	Polyamide PA6

**Order information**

Screw terminal:	<b>CRINT-C118/UC...V</b>	<b>UC12V</b> <b>UC24V</b> <b>UC48V</b>
Cage clamp terminal:	<b>CRINT-C128/UC...V</b>	<b>UC60V</b> <b>UC110-125V</b> <b>UC220-240V</b>

„ ...“ enter the voltage for full type designation

**Accessories**

Jumper link (5 pcs):	blue:	<b>CRINT-BR20-BU/5</b>
	red:	<b>CRINT-BR20-RD/5</b>
	black:	<b>CRINT-BR20-BK/5</b>

Label plate (64 pcs):	<b>CRINT-LAB/64</b>
Spacer (5 pcs):	<b>CRINT-SEP/5</b>

Replacement relays:	<b>DC12V</b> <b>DC24V</b> <b>DC60V*</b>
---------------------	---

„ ...“ enter the voltage for full type designation

\*60V Relay used for all sockets with a nominal voltage higher or equal 60V



**Connection diagram**

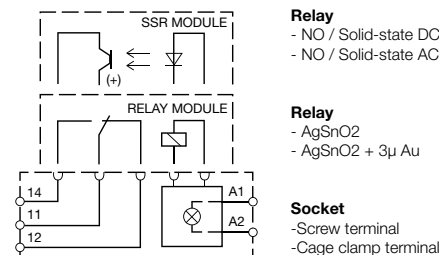

**Output derating curve**

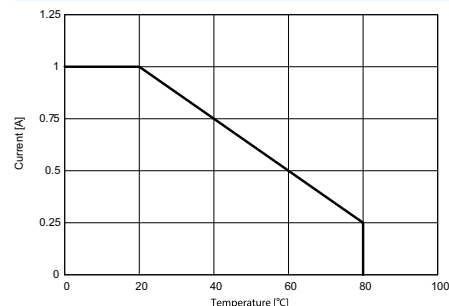

**Dimensions p.72**

**Technical approvals, conformities**

