

Photoelectrics Retro-reflective Type PA18C.R..., DC



- Miniature sensor range
- Range: 6.5 m (Axial), 5 m (Radial)
- Sensitivity adjustment by potentiometer
- Modulated, infrared light 850 nm
- Supply voltage: 10 to 30 VDC
- Output: 100 mA, NPN or PNP, N.O & N.C.
- Degree of protection IP67, IP69K
- LED indication for output, stability and power ON
- Protection: reverse polarity, short circuit and transients
- Cable and plug versions
- Excellent EMC performance



Product Description

The PA18C.R... is part of a family of inexpensive general purpose retro-reflective sensors in industrial standard 18 mm cylindrical ABS housing. The sensors are useful in applications where high-accuracy detection as well as small size is required.

Compact housing and high power LED for excellent performance-size ratio. The potentiometer used for adjustment of the sensitivity makes the sensors highly flexible. The output type is NPN or PNP and the output switching function is NO and NC.

Ordering Key

PA18CAR65PAM1SA

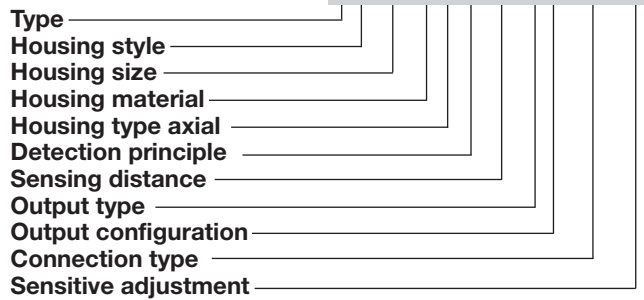

Type Selection

Housing style	Range S _n	Connection	Ordering no. NPN Make & break switching	Ordering no. PNP Make & break switching
M18 Axial type	6.5 m	Cable	PA 18 CAR 65 NASA	PA 18 CAR 65 PASA
M18 Axial type	6.5 m	Plug	PA 18 CAR 65 NAM1SA	PA 18 CAR 65 PAM1SA
M18 Radial type	5.0 m	Cable	PA 18 CRR 50 NASA	PA 18 CRR 50 PASA
M18 Radial type	5.0 m	Plug	PA 18 CRR 50 NAM1SA	PA 18 CRR 50 PAM1SA

Specifications according to EN60947-5-2

Rated operating distance (S_n) Axial type (A) Radial type (R)	Up to 6.5 m, Up to 5.0 m reference target ER4 reflector ø 80 mm
Blind zone	50 mm @ S _n max.
Sensitivity control Electrical adjustment Mechanical adjustment Adjustable distance to target Axial types Radial types	Adjustable by potentiometer 210° 240° 50-650 cm 50-500 cm
Temperature drift	≤ 0.2%/°C
Hysteresis (H) (differential travel)	≤ 20%
Rated operational volt. (U_B)	10 to 30 VDC (ripple included)
Ripple (U_{rip})	≤ 10%
Output current Continuous (I _a) Short-time (I)	≤ 100 mA ≤ 100 mA (max. load capacity 100 nF)

No load supply current (I_o)	≤ 25 mA @ 24 VDC
Minimum operational current (I_m)	0.5 mA
OFF-state current (I_r)	≤ 100 µA
Voltage drop (U_d)	≤ 2.0 VDC @ 100 mA
Protection	Short-circuit, reverse polarity and transients
Light source	LED, 850 nm
Light type	Infrared, modulated
Sensing angle	± 2°
Ambient light	30.000 lux Incandescent lamp
Light spot Diameter	Ø 164 mm @ 3.25 m
Operating frequency	500 Hz
Response time OFF-ON (t _{ON}) ON-OFF (t _{OFF})	≤ 1.0 ms ≤ 1.0 ms
Power ON delay (t_v)	≤ 100 ms
Output function Type Switching function	NPN or PNP NO and NC



Specifications (cont.)

Indication Output ON Signal stability and power ON	LED, yellow LED, green	Housing material Body Front material Cable gland Trimmer shaft Locknuts Mounting bracket	ABS, grey PMMA, red POM, Black POM, Dark Grey PBTB, black PPA, black
Environment Installation category Pollution degree Degree of protection	III (IEC 60664/60664A; 60947-1) 3 (IEC 60664/60664A; 60947-1) IP 67, IP 69K*	Connection Cable Plug	PVC, grey, 2 m 4 x 0.25 mm ² , Ø = 4.5 mm M12, 4-pin (CONM14NF-series)
Ambient temperature Operating Storage	-25° to +60°C (-13° to +140°F) -40° to +70°C (-40° to +158°F)	Weight	With cable: 85 g With plug: 25 g
Vibration	10 to 150 Hz, 1 mm/15 g (IEC 60068-2-6)	CE-marking	Yes
Shock	30 g / 11ms, 3 pos, 3 neg per axis (IEC 60068-2-6, 60068-2-32)	Approvals	cULus (UL508) supply class 2
Rated insulation voltage	500 VAC (rms) IEC protection class III		

* The IP69K test according to DIN 40050-9 for high-pressure, high-temperature wash-down applications. The sensor must not only be dust tight (IP6X), but also able to withstand high-pressure and steam cleaning. The sensor is exposed to high pressure water from a spray nozzle that is fed with 80°C water at 8'000–10'000 KPa (80–100bar) and a flow rate of 14–6L/min. The nozzle is held 100–150 mm from the sensor at angles of 0°, 30°, 60° and 90° for 30s each. The test device sits on a turntable that rotates with a speed of 5 times per minute. The sensor must not suffer any damaging effects from the high pressure water in appearance and function.

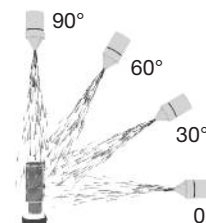

Operation Diagram

tv = Power ON delay

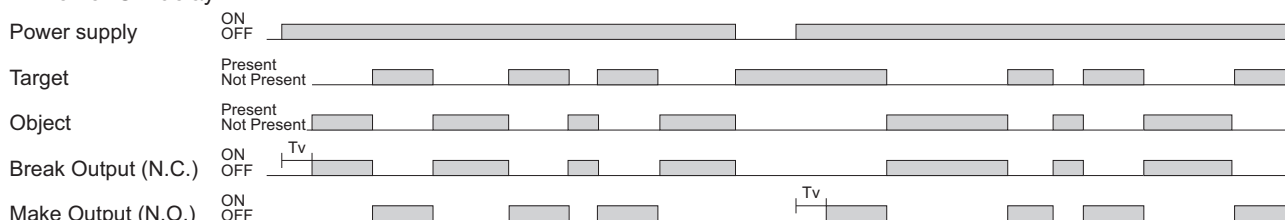

Wiring Diagrams

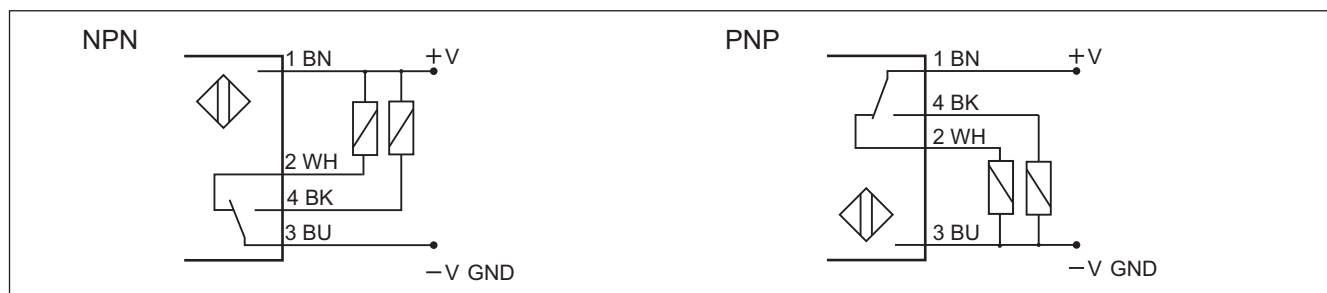

Detection Diagram

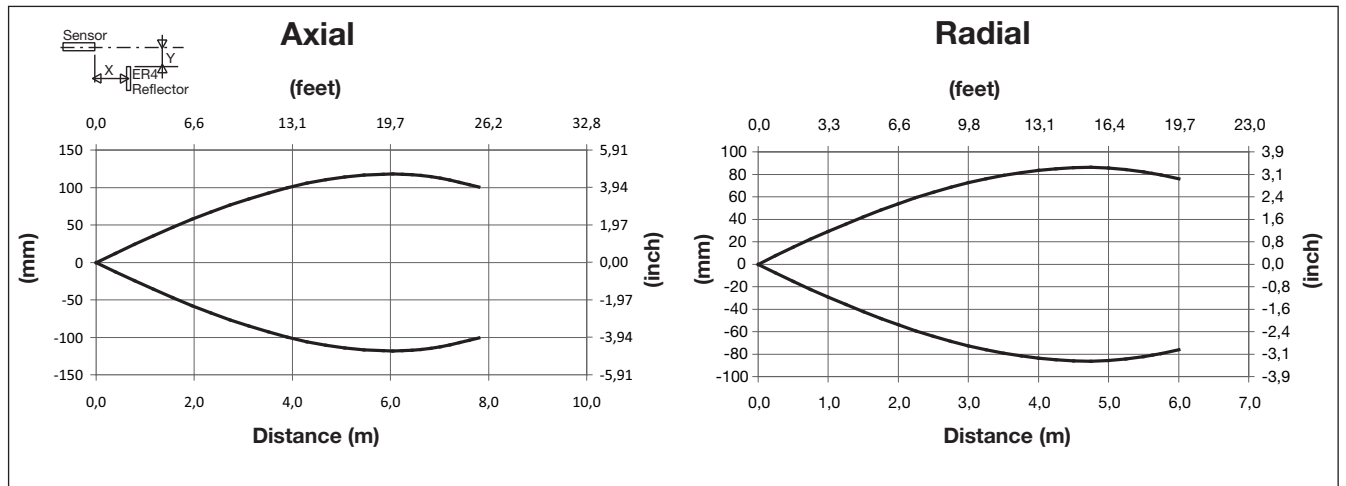

Excess Gain

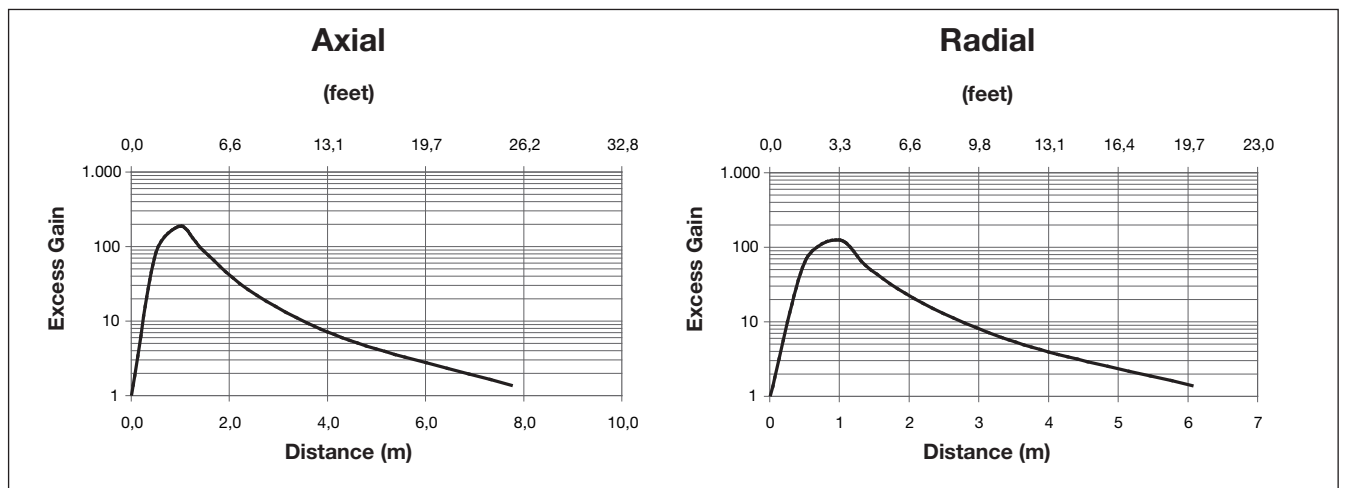

Signal Stability Indication

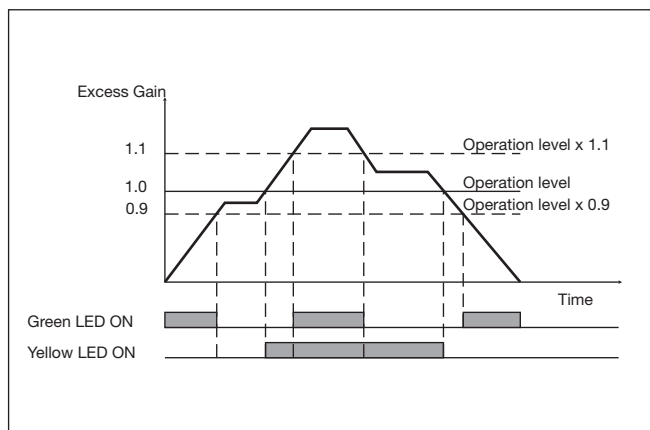

APA 18-MB1

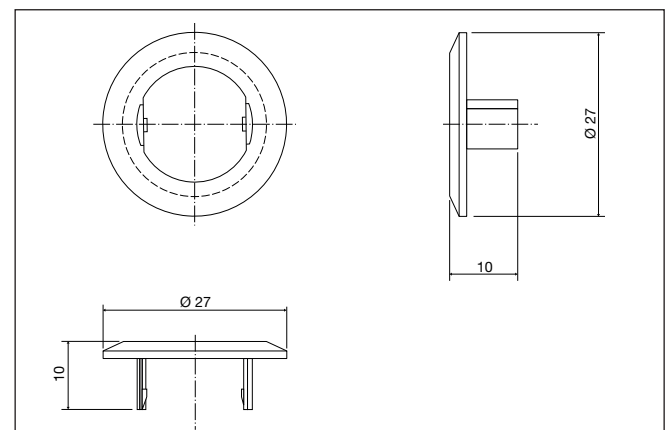

Dimensions Radial version

Cable version

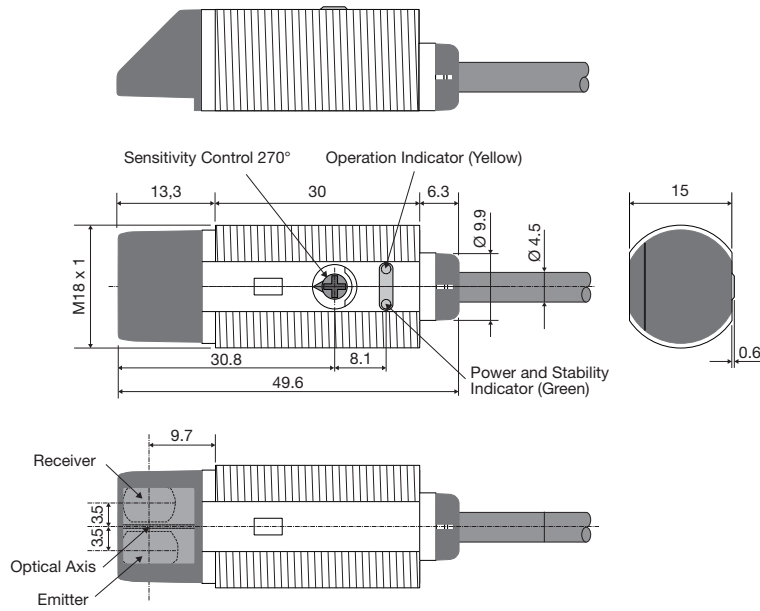

Plug version

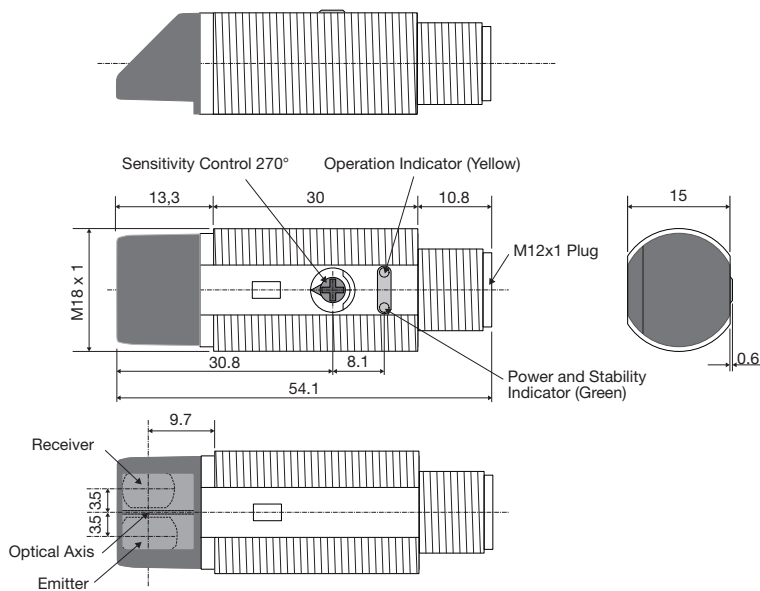

Dimensions Axial version

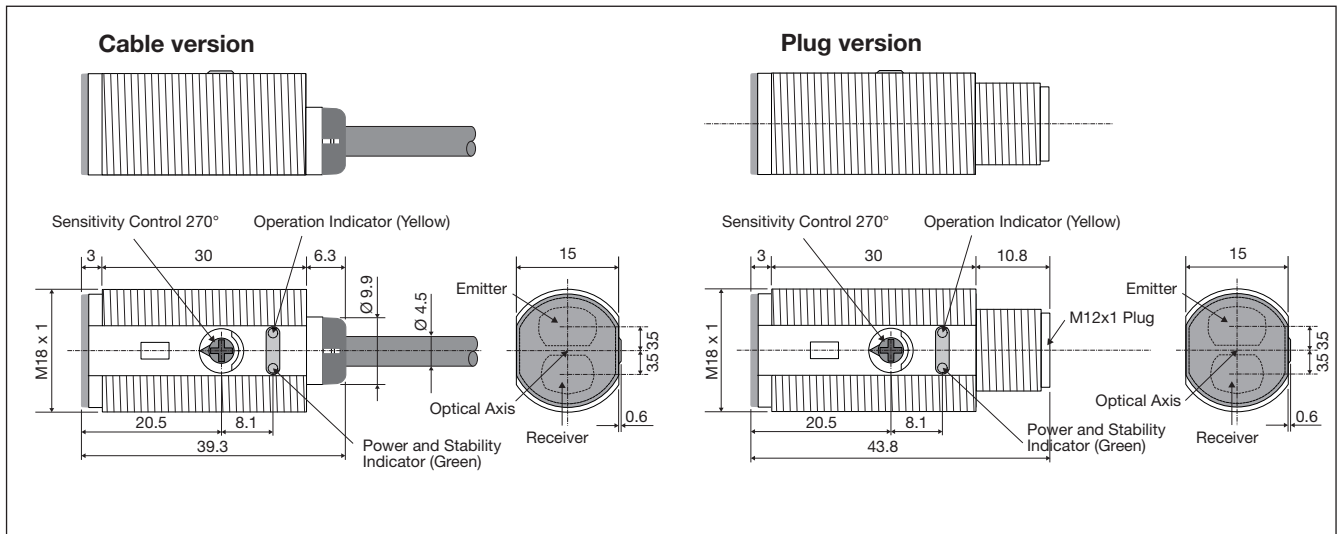

Mounting Systems

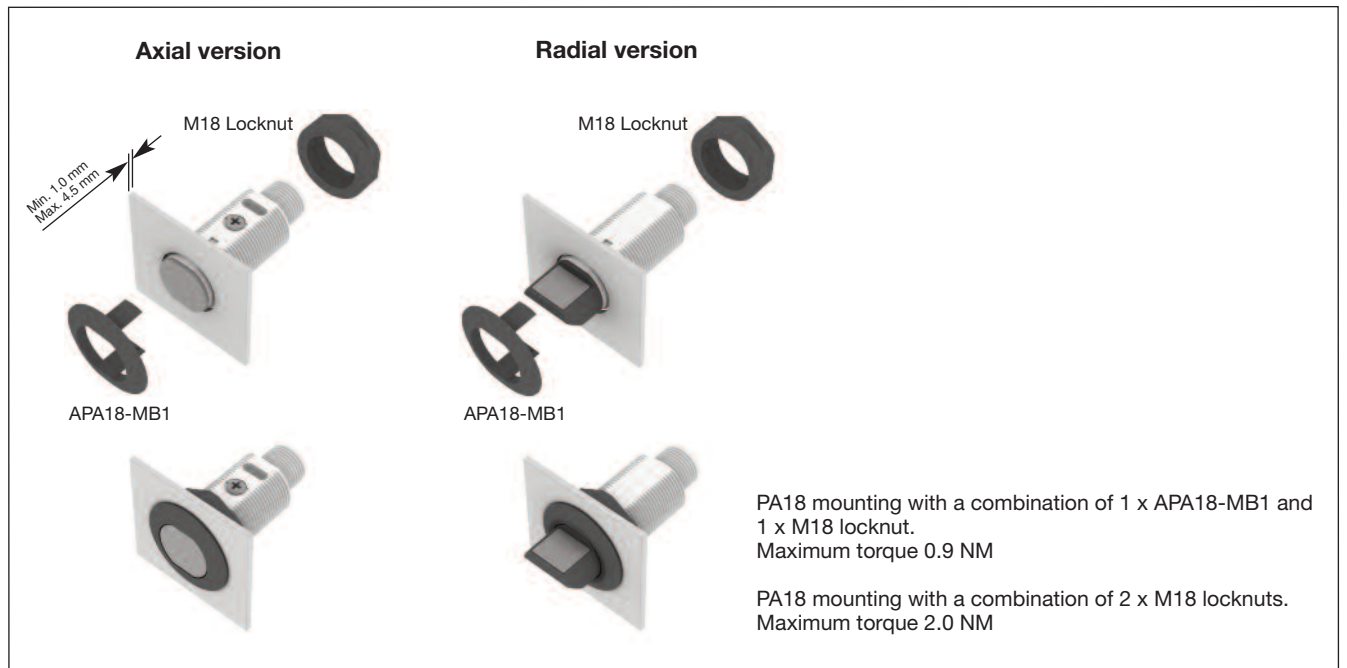

Installation Hints

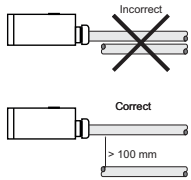
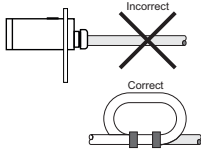
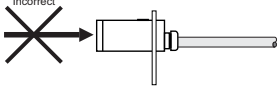
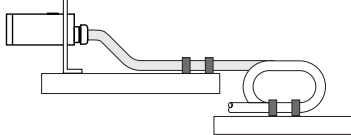
<p><i>To avoid interference from inductive voltage / current peaks, separate the proximity switch cables from any other power cables. E.g. Engine, contactor or solenoid cables</i></p>  <p>Incorrect</p> <p>Correct</p> <p>> 100 mm</p>	<p><i>Relief of the cable strain</i></p>  <p>Incorrect</p> <p>Correct</p> <p><i>The cable should not be pulled</i></p>	<p><i>Protection of the sensing face</i></p>  <p>Incorrect</p> <p><i>A proximity switch should not serve as mechanical stop</i></p>	<p><i>Sensor mounted on a mobile carrier</i></p>  <p><i>Any repetitive flexing of the cable should be avoided</i></p>
--	---	--	--

Delivery Contents

- Photoelectric switch: PA 18 C.R...
- Installation instruction on plastic bag
- Screwdriver
- Mounting bracket APA18-MB1
- 2 M18 locknuts
- **Packaging:** Plastic bag

Accessories

- Connector type CONG1A.. / CONM14NF.. series
- Reflector type ER.. - to be purchased separately