

## Analogue Temperature Transmitters Model T91.30, Fixed Measuring Range, Rail Mounting

WIKAI Data Sheet TE 91.02

### Applications

- Plant construction
- Power engineering
- Heating, air condition, ventilation, refrigeration

### Special Features

- Designs for Pt100 / Pt1000 or thermocouples
- Output 0 ... 10 V, 3-wire design
- Fault signal for sensor burnout
- High accuracy
- Compact and cost-effective



Analogue Temperature Transmitter Model T91.30

### Description

The analogue temperature transmitters of the T91 family are geared to the special requirements of industrial applications. They are ideally suited for direct connection to processors such as PLCs or PC-A/D converters with voltage input.

The transmitters convert the temperature-dependent change in resistance (for resistance thermometers) or the temperature-dependent change in voltage (for thermocouples) into a 0 ... 10 V output signal. This standard signal allows an easy and reliable transmission of temperature measurement values.

These temperature transmitters are characterised by fixed measuring ranges configured according to customer

specifications, combined with zero and span potentiometers, which enable the fine adjustment of small corrections on site. Industry-compliant accuracy, interference resistance and sensor monitoring are further features of these compact signal converters.

The T91.30.232 rail-mounting transmitter offers a useful special feature: The sensor input and the analogue output are galvanically isolated. For this reason the T91.30.232 is ideal for fast measurements with non-insulated or base-metal thermocouples.

The rail-mounting case of these transmitters is suitable for all standard rails per DIN EN 50 022-35.

Specifications	Model T91.30				
	214	224	254	212	232
<b>Sensors/Input</b>					
Input	Pt100/Pt1000 DIN EN 60 751 2- / 3- / 4-wire		Pt100/Pt1000 DIN EN 60 751 2- / 3-wire		Thermoelemente DIN EN 60 584 K, J (L), T (U)
Minimum span	20 K				200 K
Maximum span	850 K				-
Standard measuring ranges	see page 4				see page 4
Sensor current	0.8 ... 1 mA <sup>1)</sup>				-
Adjustable range					
■ Zero potentiometer (Z)	±5 K				±5 K
■ Span potentiometer (S)	±5 K				±5 K
Cold-junction compensation	-				yes
<b>Analogue output</b>	0 ... 10 V, short-circuit-proof, 3-wire design <sup>2)</sup>				0 ... 10 V, short-circuit-proof, 3-wire design <sup>2)</sup>
Linearisation	Linear to temperature per DIN EN 60 751				Linear to voltage
Accuracy	< 0.1 % FS		< 1 % FS		< 1 % FS
Temperature coefficient					
■ Zero	< 100 ppm/°C				< 100 ppm/°C
■ Span	< 100 ppm/°C				< 100 ppm/°C
Error effect of cold-junction compensation	-				< 0.5 °C
Rise time (response time)	< 0.1 s				< 0.1 s
Signalling sensor burnout	> 10 V				> 10 V
Sensor short circuit	0 V				Voltage value for ambient temperature
Minimum load resistance	3 kOhm				3 kOhm
Maximum current consumption	20 mA	40 mA	20 mA	20 mA	40 mA
Insulation voltage (input to analogue output)	-			-	1 kV
<b>Power supply</b>	15 ... 35 VDC				15 ... 35 VDC
Input power supply	Protected against reverse polarity				Protected against reverse polarity
Maximum permissible ripple	< 10 %				< 10 %
Electromagnetic compatibility	2004/108/EC, EN 61 326 Emission (Group 1, Class B)				and Immunity (industrial locations)
Storage temperature	-25 ... +85 °C				-25 ... +85 °C
Operating temperature	-25 ... +85 °C				-25 ... +85 °C
Maximum permissible humidity	< 95 %				< 95 %
Vibration	5 g / 10 ... 200 Hz				5 g / 10 ... 200 Hz
<b>Case</b>					
Material	Polycarbonate				Polycarbonate
Ingress protection					
■ Case	IP 30 IEC 529 / DIN EN 60 529				IP 30 IEC 529 / DIN EN 60 529
■ Terminals	IP 10 IEC 529 / DIN EN 60 529				IP 10 IEC 529 / DIN EN 60 529
Terminals	Screw terminals				Screw terminals
Cross section of terminals	0.2 ... 2.5 mm <sup>2</sup>				0.2 ... 2.5 mm <sup>2</sup>
Weight	approx. 60 g		approx. 35 g		approx. 60 g
Dimensions	75 x 25 x 53 mm		75 x 15 x 53 mm		75 x 25 x 53 mm

1) Depending on the sensor resistance

2) Output signal e.g. 0 ... 2.5 V, 0 ... 5 V or 1 ... 5 V on request

## Possible measuring ranges

Input	Maximum range in Celsius		Span in Kelvin	
	Minimum (lower limit)	Maximum (upper limit)	Minimum	Maximum
<b>Pt100</b>	-200 °C	+850 °C	20 K	850 K
<b>Pt1000</b>	-200 °C	+380 °C	20 K	400 K
<b>TC Type T</b>	-200 °C	+400 °C	200 K	600 K
<b>TC Type J</b>	-100 °C	+1200 °C	200 K	1300 K
<b>TC Type L</b>	-200 °C	+900 °C	200 K	1100 K
<b>TC Type K</b>	-200 °C	+1320 °C	200 K	1520 K
<b>TC Type U</b>	-200 °C	+600 °C	200 K	600 K

## Dimensions in mm

Model T91.30.212 / 214 / 224 / 232

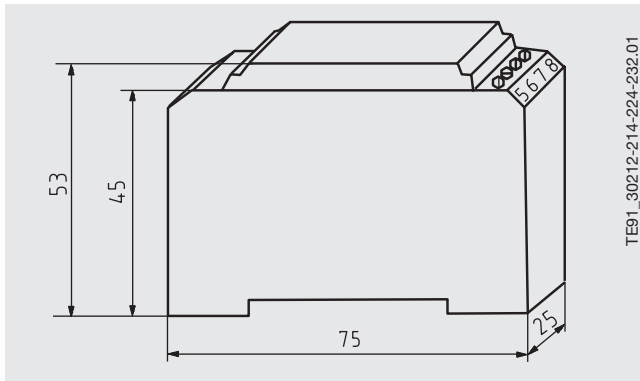

Model T91.30.254

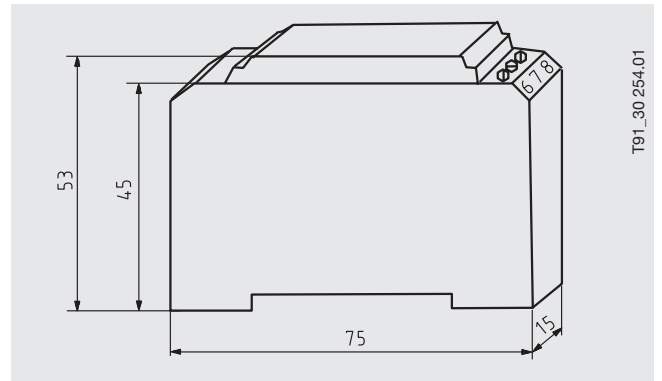

## Designation of terminal connectors

Model T91.30.212 / 232

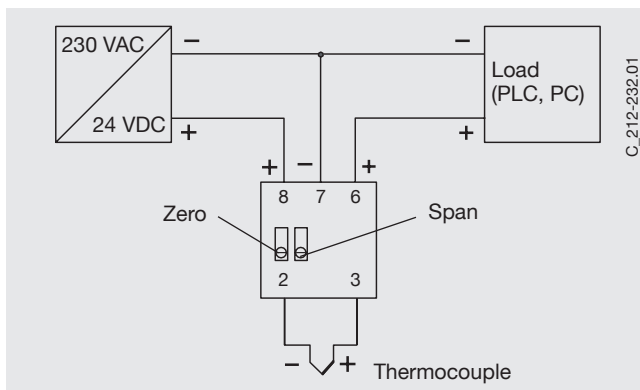

Model T91.30.214

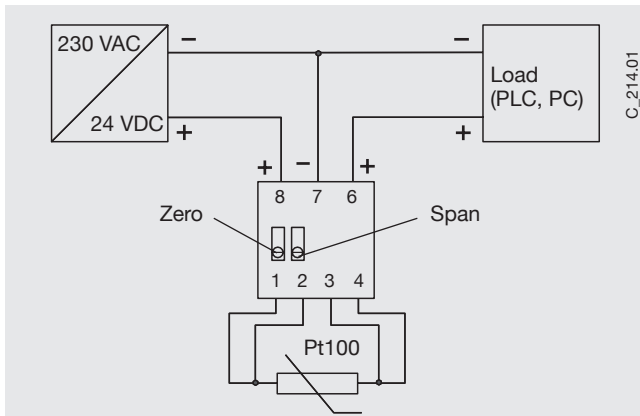

Model T91.30.224

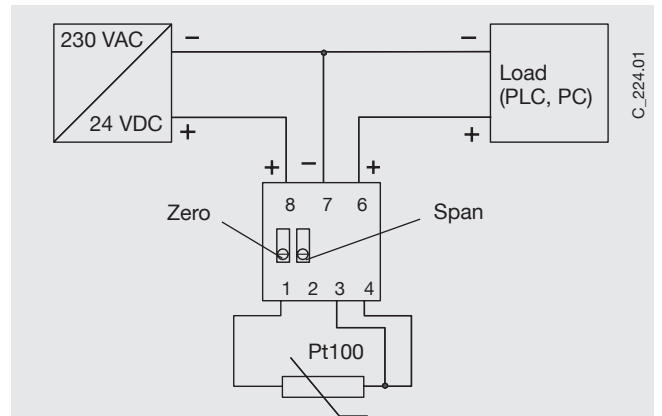

Model T91.30.254

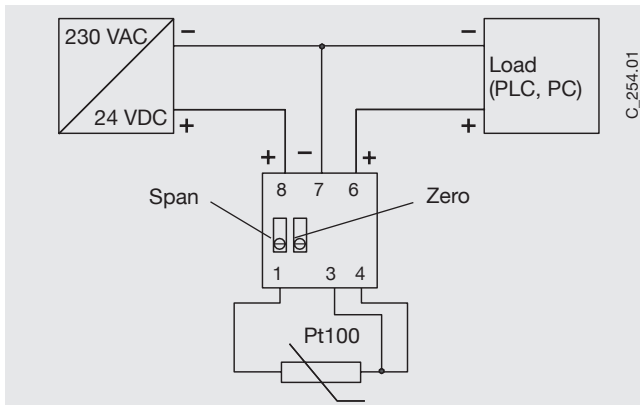

# Ordering information for Temperature Transmitter Model T91.30

Field Nr.	Code	Features
		<b>Operating range</b>
1	<input type="text"/>	<b>212</b> Thermocouple; accuracy 1 %
	<input type="text"/>	<b>232</b> Thermocouple; galv. isolated, accuracy 1 %
	<input type="text"/>	<b>214</b> Pt100; 2- / 3- / 4-wire; accuracy 0.1 %
	<input type="text"/>	<b>224</b> Pt100; 2- / 3-wire; accuracy 0.1 %
	<input type="text"/>	<b>254</b> Pt100; 2-/ 3-wire; accuracy 1 %
		<b>Input</b>
2	<input type="text"/>	<b>1P</b> Resistance thermometer Pt100
	<input type="text"/>	<b>1T</b> Resistance thermometer Pt1000
	<input type="text"/>	<b>3J</b> Thermocouple type J (Fe-CuNi)
	<input type="text"/>	<b>3K</b> Thermocouple type K (NiCr-Ni)
	<input type="text"/>	<b>3L</b> Thermocouple type L (Fe-CuNi)
	<input type="text"/>	<b>3T</b> Thermocouple type T (Cu-CuNi)
	<input type="text"/>	<b>3U</b> Thermocouple type U (Cu-CuNi)
		<b>Output signal</b>
3	<input type="text"/>	<b>F</b> 0 ... 10 VDC, 3-wire design
		<b>Measuring range</b>
4	<input type="text"/>	<b>CND</b> -200 °C ... +100 °C
	<input type="text"/>	<b>CEL</b> -50 °C ... +200 °C
	<input type="text"/>	<b>CEQ</b> -50 °C ... +400 °C
	<input type="text"/>	<b>CEA</b> -50 °C ... +50 °C standard (Pt100)
	<input type="text"/>	<b>CCB</b> -30 °C ... +50 °C
	<input type="text"/>	<b>CCC</b> -30 °C ... +60 °C
	<input type="text"/>	<b>CCD</b> -30 °C ... +70 °C
	<input type="text"/>	<b>C1A</b> 0 °C ... +50 °C
	<input type="text"/>	<b>C1H</b> 0 °C ... +150 °C standard (Pt100)
	<input type="text"/>	<b>C1L</b> 0 °C ... +200 °C
	<input type="text"/>	<b>C1M</b> 0 °C ... +250 °C
	<input type="text"/>	<b>C1N</b> 0 °C ... +300 °C standard (Pt100)
	<input type="text"/>	<b>C1P</b> 0 °C ... +350 °C standard (thermocouple)
	<input type="text"/>	<b>C1Q</b> 0 °C ... +400 °C
	<input type="text"/>	<b>C1S</b> 0 °C ... +500 °C
	<input type="text"/>	<b>C1U</b> 0 °C ... +600 °C standard (thermocouple)
	<input type="text"/>	<b>C1W</b> 0 °C ... +700 °C
<input type="text"/>	<b>C11</b> 0 °C ... +1000 °C	
<input type="text"/>	<b>???</b> others	
		<b>Additional order information</b>
5	<input type="text"/>	<b>YES</b> <b>NO</b>
	<input type="text"/>	<b>T</b> <b>Z</b> Additional text

## Order code:

	1	2	3	4	5		
T91.30.	<input type="text"/>	-	<input type="text"/>	<input type="text"/>	-	<input type="text"/>	<input type="text"/>

**Additional text:** \_\_\_\_\_

Modifications may take place and materials specified may be replaced by others without prior notice. Specifications and dimensions given in this leaflet represent the state of engineering at the time of printing.



**WIKAL Alexander Wiegand SE & Co. KG**  
 Alexander-Wiegand-Straße 30  
 63911 Klingenberg/Germany  
 Tel. (+49) 9372/132-0  
 Fax (+49) 9372/132-406  
 E-mail info@wika.de  
 www.wika.de