

Precision high-pressure controller Model CPC8000-H

mentor

WIKA data sheet CT 28.05



Applications

- Transmitter and pressure gauge manufacturers
- Calibration and service companies
- Industry (laboratory, workshop and production)
- Research and development laboratories
- National institutes and institutions

Special features

- Pressure ranges: 0 ... 1,600 bar / 0 ... 23,000 psi
- Pressure medium: Hydraulic oil or water
- Control stability: 0.005 % of FS
- Accuracy: to 0.01 % of FS
- Interchangeable reference pressure sensors



Precision high-pressure controller, model CPC8000-HC

Description

Application

The model CPC8000-H precision hydraulic high-pressure controller is especially suited as a factory/working standard for the automatic testing or calibration of all types of high-pressure measuring instruments, due to its high accuracy and control stability. However, autofrettage applications or cyclic pressure-load tests are also ideal application areas, thanks to its robustness and reliability.

For the supply to the controller, other than the voltage supply, only clean dry compressed air for the pneumatic control circuit is needed. As a pressure medium on the output side, hydraulic oil or water (or other media on request) can be used.

Design

The CPC8000-H consists of two components, the model CPC8000-HC pressure controller and the model CPC8000-HM hydraulic module with the reference pressure sensors. The complete system is available as a 19" plug-in case or

built into a 19" rack. The sensors can be changed via the front of the hydraulic module, without having to dismantle the complete controller (e.g. out of a calibration rig).

Functionality

Through its specialist technology, the desired pressure value from the controller is regulated quickly and simply. Maximum ease-of-use is achieved through the large touchscreen and the simple and intuitive menu navigation. In addition, its easy operability is further supported by the availability of a large number of menu languages.

On the large touchscreen, all necessary information such as current measured value and set point can be found on a single screen. Optionally, the measured values can be displayed in other pressure units additionally. The pressure controller can be remotely controlled via serial interfaces available. Through these, a wide range of emulation command sets for other pressure controllers are available.

Interface

For communication and data transfer with a PC, the instrument has an IEEE-488.2, RS-232, USB and Ethernet interface. The digital interfaces enable the software-controlled operation of the controller - such as fully-automated calibration processes or the running of specific test programs generated from LabVIEW® etc..

Complete test and calibration systems

On request, complete mobile or stationary test systems can be manufactured.

Specifications

Reference pressure sensors

Model CPR8050

Accuracy 1)	0.01 % FS
Gauge pressure	0 ... 400 bar to 0 ... 700 bar / 0 ... 6,000 psi to 0 ... 10,000 psi
Precision 2)	0.005 % FS

Model CPR8850

	Standard	Advanced
Accuracy 1)	0.01 % FS	0.014 % FS
Gauge pressure	0 ... 480 bar to 0 ... ≤ 1,030 bar / 0 ... 7,000 psi to 0 ... ≤ 15,000 psi	0 ... 1,030 bar to 0 ... 1,600 bar / 0 ... 15,000 psi to 0 ... 23,000 psi
Precision 2)	0.005 % FS	0.007 % FS

- 1) The accuracy is defined by the total measurement uncertainty, which is expressed with the coverage factor ($k = 2$) and includes the following factors: the intrinsic performance of the measuring instrument, the measurement uncertainty of the reference instrument, long-term stability, influence of ambient conditions, drift and temperature effects over the compensated range during a periodic zero point adjustment.
- 2) The precision is the maximum deviation between two measurements at one point under laboratory conditions which contains linearity, hysteresis and repeatability of the measuring instrument.

Model CPC8000-HM hydraulic module

Instrument

Instrument version	Standard: 19" rack-mounting with side panels incl. rack-mounting kit Optional: built into a 19" rack with CPC8000-HC pressure controller
Dimensions in mm	see technical drawings
Weight	approx. 87.5 kg / approx. 193 lb

Connections

Pressure connections	Drive-Air port: 6 mm SWAGELOK® threaded pipe connection Supply port: 6 mm SWAGELOK® threaded pipe connection Measure/Control port: ¼" SNOTRIK® threaded pipe connection
Permissible pressure media	Drive-Air port: clean and dry air or nitrogen Supply port: clean and dry air or nitrogen Measure/Control port: non-corrosive liquids

Permissible pressure

Drive-Air port (from CPC8000-HC)	8 ... 35 bar / 116 ... 508 psi
Supply port	10 ... 35 bar / 145 ... 508 psi
Measure/Control port	max. 105 % FS

Control parameters

Control stability	< 0.005 % FS
Control time	< 60 s
Control range	20 bar to full scale / 290 psi to full scale
Test volume	10 ... 1,000 ccm

Permissible ambient conditions

Operating temperature	15 ... 40 °C / 59 ... 104 °F
Storage temperature	5 ... 70 °C / 41 ... 158 °F
Relative humidity	0 ... 95 % r. h. (non-condensing)
Compensated temperature range	15 ... 40 °C / 59 ... 104 °F
Mounting position	Horizontal

Pressure controller model CPC8000-HC

Instrument

Instrument version	Standard: 19" rack-mounting with side panels incl. rack-mounting kit Optional: built into a 19" rack with CPC8000-HM hydraulic module
Warm-up time	approx. 25 min
Dimensions in mm	see technical drawings
Weight	approx. 21 kg / approx. 46.3 lb

Display

Screen	9.0" colour TFT with touchscreen
Resolution	4 ... 7 digits
Input methods	capacitive touchscreen

Connections

Pressure connections	7/16"-20 F SAE
Pressure adapters	6 mm SWAGELOK® threaded pipe connection; others on request
Filter elements	all pressure ports have 20-micron filters
Permissible pressure media	Dry, clean air or nitrogen
Overpressure protection	Safety relief valve

Permissible pressure

Supply port	8 ... 35 bar / 116 ... 508 psi
Measure/Control port	max. 105 % FS

Voltage supply

Power supply	AC 100 ... 120 V / 200 ... 240 V, 50 ... 60 Hz
Power consumption	130 VA

Permissible ambient conditions

Operating temperature	15 ... 45 °C / 59 ... 113 °F
Storage temperature	5 ... 70 °C / 41 ... 158 °F
Relative humidity	0 ... 95 % r. h. (non-condensing)
Compensated temperature range	15 ... 45 °C / 59 ... 113 °F
Mounting position	Horizontal

Communication

Interface	IEEE-488.2, Ethernet, USB, RS-232
Command sets	Mensor, WIKA SCPI
Response time	< 100 ms

CE conformity, approvals, certificates for CPC8000-H

CE conformity

EMC directive ³⁾	2004/108/EC, EN 61326-1 emission (group 1, class B) and interference immunity (industrial application)
Low voltage directive	2006/95/EC, EN 61010-1

Approval

GOST	Metrology/measurement technology, Russia
------	--

Certificate

Calibration ⁴⁾	Standard: 3.1 calibration certificate per EN 10204 Option: DKD/DAkkS calibration certificate
---------------------------	---

3) **Warning!** This is class A equipment for emissions and is intended for use in industrial environments. In other environments, e.g. residential or commercial installations, it can interfere with other equipment under certain conditions. In such circumstances the operator is expected to take the appropriate measures.

4) Calibration in a horizontal position.

Approvals and certificates, see website

Dimensions in mm

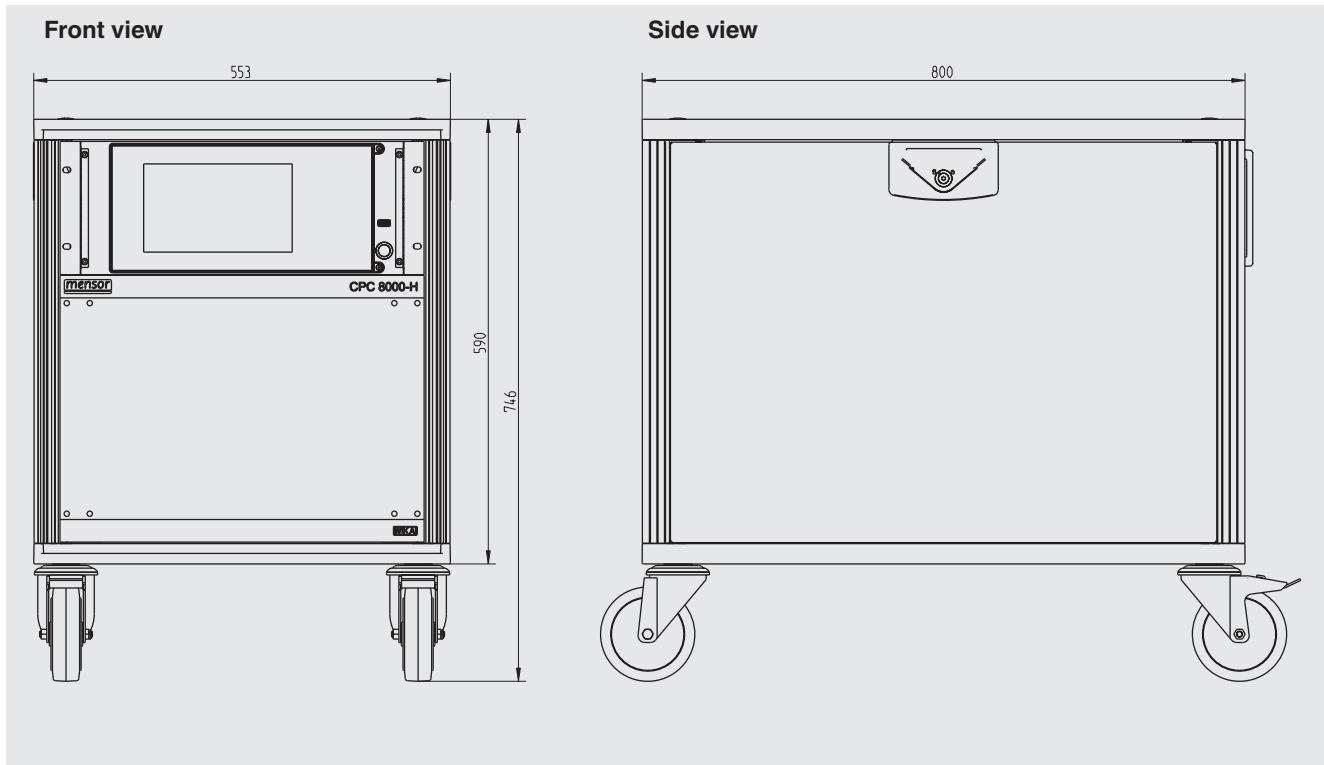

Modular design of the CPC8000-H

Due to the modular sensor design, the large pressure range of up to 1,600 bar and the ability to exchange the sensors from the front, the CPC8000 precision high-pressure controller offers a maximum degree of flexibility in terms of hardware design or a subsequent sensor expansion.

Up to two precision pressure sensors possible

The controller offers at least one precision pressure sensor (optionally two), whose calibration data is stored in the sensor (for available ranges, see specifications).

Extremely easy to maintain

The instrument offers the maximum ease-of-service and the highest possible adaptability in the shortest time, since sensors of different pressure ranges can be exchanged in just 15 minutes (plug-and-play).



Precision high-pressure controller, model CPC8000-HC

Special features of the CPC8000-H

Outstanding control performance

The model CPC8000-H high-pressure controller is especially notable for its outstanding control performance. The control unit guarantees fast, simple and overshoot-free control of pressure values with the highest precision and a high control stability.

Particularly adaptable to any application

The controller has a short warm-up time of approx. 25 minutes. In addition, it can be automatically adapted to the test volume.

Simple operation

The lean and unambiguous menu structure ensures a particularly high user-friendliness.

Bleed priming function

The bleed priming function ensures automatic filling (10 ... 12 bar) of the control circuit, so that larger test volumes also do not present any problem.

Long-term stability and low maintenance

As a result of the high-quality precision pressure sensor technology, the instrument offers an excellent measuring accuracy and long-term stability. Furthermore, special patented needle valve technology ensures a low-noise and low-wear control of pressure.

Touchscreen and intuitive operator interface

The CPC8000-H high-pressure controller has a high-resolution colour touchscreen with an intuitive menu structure. The instrument features a precision pressure controller whose interface, incl. optional functions, can be easily configured via touchscreen.

Standard desktop/main screen

Selection of the active sensor → Range Hold

Pressure range of the sensor → -1.00 ... 1999.00

Entered set point → 1.00

Current measured value → -0.09

Current unit → bar Gauge

Adjustable control limits → |< -0.00 1600.00 >|

optionally settable: second unit → -1.4 psi

Operating modes → Measure Control Vent

Settings

Selection: Numeric keypad, settings and favourites

Input menu field (Numeric/Step Funct./Jog Funct.)

Display: integrated barometer, serial interface communication status, touchscreen lockout and warnings

MEASURE
In Measure mode, the pressure present at the test port is measured with high accuracy (if you switch directly from **CONTROL** to **MEASURE** mode, the last controlled pressure in the connected test assembly will be maintained/locked).

CONTROL
In control mode the instrument provides a very precise pressure at the test port of the respective channel in accordance with the desired set point parameter.

VENT
The system controls gently to a non-critical value and then vents the system, including the test assembly connected to the test port, to atmosphere.

Scope of delivery model CPH8000-H

- Pressure controller model CPC8000-HC, 19" built-in version
- Hydraulic module model CPC8000-HM, 19" mounting version
- Pneumatic hose for connecting the CPC8000-HC with CPC8000-HM, approx. 1 m / 3.3 ft
- Power cord 2 m / 6.5 ft
- Operating instructions
- 3.1 calibration certificate per DIN EN 10204

Options

- DKD/DAkkS calibration certificate
- System built into a 19" rack with rollers
- Additional reference pressure sensors
- Customer-specific system

Accessories

- Interface cable

Ordering information

Model / Housing type / Instrument version / Reference pressure sensor 1 / Reference pressure sensor 2 / Type of certificate for the barometric reference / Medium / Additional order information

© 2006 WIKA Alexander Wiegand SE & Co. KG, all rights reserved.
The specifications given in this document represent the state of engineering at the time of publishing.
We reserve the right to make modifications to the specifications and materials.



WIKAL Alexander Wiegand SE & Co. KG
Alexander-Wiegand-Straße 30
63911 Klingenberg/Germany
Tel. +49 9372 132-0
Fax +49 9372 132-406
info@wika.de
www.wika.de