

Model CFT34A Coriolis Flow Transmitter



The CFT34A Coriolis flow transmitter can be used with the CFS300A, CFS400A, CFS600A and CFS700A Coriolis flow sensors.

- ▶ High performance transmitter for all applications, developed according to IEC 61508, SIL 2/3
- ▶ In multi-phase applications due to entrained gas control
- ▶ Smart diagnostics according to NAMUR NE 107

Equipment should be installed, operated, serviced, and maintained only by qualified personnel.

No responsibility is assumed by Schneider Electric for any consequences arising from the use of this material.

1 Product features	3
1.1 The high performance transmitter for all applications	3
1.2 Options and variants	5
1.3 Transmitter / flow sensor combination possibilities	7
1.4 Measuring principle.....	7
2 Technical data	8
2.1 Technical data.....	8
2.2 Dimensions and weight	19
2.2.1 Housing	19
2.2.2 Mounting plate of field housing	20
3 Model code	21

1.1 The high performance transmitter for all applications

The **CFT34A** Coriolis mass flow transmitter will provide the highest performance possible across a wide range of applications. For the measurement of liquids or gases, cryogenic to high temperature fluids, single or multi-phase fluids and advanced digital signal processing techniques is used to give accurate measurements of mass flow, density and temperature.

It is developed according to IEC 61508 and depending on the I/O and flow sensor variant suited for use in safety applications SIL 2/3.

Conforming to the NAMUR standard NE 107 for status and error handling, the CFT34A features enhanced meter diagnostics. This provides extensive self-checking of internal circuits and information regarding the health of the flow sensor, but just as importantly, vital information about the process and process conditions.

Measuring values and diagnostic information can be transmitted via field bus interfaces including HART®, RS485 Modbus, FOUNDATION™ Fieldbus and PROFIBUS®.



(transmitter in field housing)

- ① Supply voltage: 100...230 VAC (standard) and 24 VDC
- ② Communication with any third party system possible via HART®, Modbus, FOUNDATION™ Fieldbus and PROFIBUS®
- ③ Intuitive navigation and a wide variety of languages integrated as standard for ease of operation

Highlights

- High performance transmitter with multiple output options
- Developed according to IEC 61508
- Configuration via local display or HART®
- Partial proof test capable
- Smart diagnostics, covering entire devices in less than a minute
- NE 107 status indicated by display background light
- Entrained gas control: meter maintains operation over a wide range of gas fractions and complex flow conditions
- Excellent long-term stability
- Optical and mechanical keys for ease of use
- Redundant data storage in transmitter housing
- Real time clock for logging events
- Overall, flexible lock concept
- HART® 7
- Communication interfaces for integration into third party systems via HART® (as standard), Modbus, FOUNDATION™ Fieldbus and PROFIBUS®

Industries

- Water & Wastewater
- Chemicals
- Power plants
- Food & Beverage
- Machinery
- Oil & Gas
- Petrochemical
- Pulp & Paper
- Pharmaceutical
- Marine

Applications

- Liquids and gases
- Liquids with gas entrainment
- Slurries and viscous products
- Concentration measurement for quality control
- Measurement of volume flow
- Measurement of density and reference density
- Custody transfer loading/unloading
- Custody transfer measurements

1.2 Options and variants

Compact design for standard applications



(Example: CFS600A (C) – compact)



(Example: CFS400A (C) – compact)

The CFT34A mass flow transmitter is available in different variants and offers superior performance in any conceivable application.

From process control in chemistry, to density and concentration measurements in the food and beverage industry, to custody transfer filling and transport measurements for oil and gas right down to conveyor systems in the pulp and paper industry.

Coriolis mass flow measuring systems measure the mass and volume flow, the density and the temperature of liquids and gases.

In addition, the concentration in mixtures and slurries can also be determined.

Thanks to the entrained gas control the CFT34A system maintains operation even with entrained gas of up to 100%.

For standard applications the compact housing is mounted directly on the flow sensor. The electronics can be easily exchanged and reconfigured using a backup data set that is stored in the housing.

Remote field housing version



(transmitter in field housing)

The transmitter in the robust field housing is generally used when it is difficult to access the measuring point or when ambient conditions do not allow the use of the compact version.

Communication options

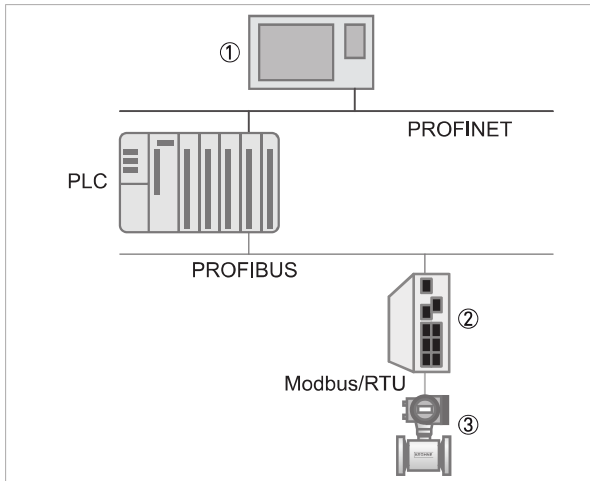

- ① Monitoring system
- ② Gateway
- ③ Flowmeter

The basic transmitter variant covers a current output including HART[®], pulse/ frequency output, status output, control input and a current input.

The modular input/output variant allows for any combination of up to four inputs and outputs. All inputs and outputs are galvanically isolated from each other and from the rest of the electronic equipment. Inputs and outputs can be passive or active.

In addition, the electronics can be equipped with fieldbus functionality including Foundation Fieldbus, Profibus PA/DP or Modbus to enable communication to any third party system.

Extensive diagnostics of the device and application

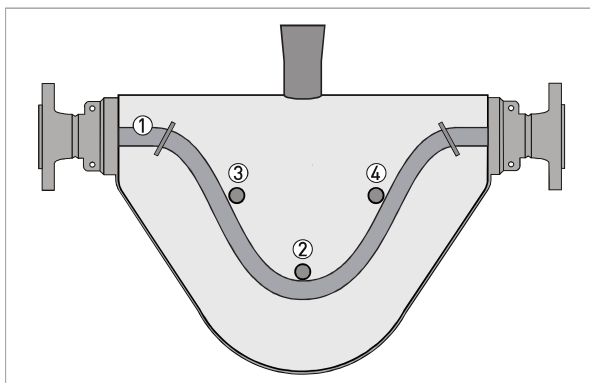

[Measuring principle (Twin tube)]

- ① Measuring tubes
- ② Drive coil
- ③ Sensor 1
- ④ Sensor 2

The primary focus of a user for a flowmeter is that it delivers reliable and robust measurements. To achieve this all Coriolis mass flowmeters are calibrated before leaving the factory.

The CFT34A provides a wide range of diagnostic functions on the flow sensor, transmitter and process integrated in the transmitter.

Potential problems that may occur in the process including gas bubbles, solids, corrosion, deposits, empty pipe and partial filling of the flow sensor.

Diagnostic information available via local display, status outputs, fieldbuses or PACTware.

1.3 Transmitter / flow sensor combination possibilities

Flow sensor	Flow sensor + transmitter CFT34A	
	Compact version	Remote field housing version
CFS300A	CFS300A (C)	CFS300A (F)
CFS400A	CFS400A (C)	CFS400A (F)
CFS600A	CFS600A (C)	CFS600A (F)
CFS700A	CFS700A (C)	CFS700A (F)

Table 1-1: Transmitter / flow sensor combination possibilities

1.4 Measuring principle

The transmitter has been designed to work with all the measuring tube designs used in the mass flowmeters. For information regarding the measuring principle for a specific measuring tube design, please refer to the technical documentation of the relevant flow sensor.

2.1 Technical data

- *The following data is provided for general applications. If you require data that is more relevant to your specific application, please contact us or your local sales office.*
- *Additional information (certificates, special tools, software,...) and complete product documentation can be downloaded free of charge from the website.*

Measuring system

Measuring principle	Coriolis principle
Application range	Measurement of mass flow, density, temperature, volume flow, flow velocity, concentration

Design

Modular construction	The measuring system consists of a flow sensor and a transmitter.
Flow sensor	
CFS300A	DN15...50 / 1/2...2"
CFS400A	DN100...400 / 4...16"
CFS600A	DN08...200 / 3/8...8"
CFS700A	DN06...80 / 1/4...3"
	All flow sensors are also available in an Ex version.
Transmitter	
Compact version (C)	CFSx00A (C) (x = 3, 4, 6 or 7)
Field housing (F) - remote version	CFT34A (F)
	Compact and field housing versions are also available in an Ex version.
Options	
Outputs / inputs	Current output (including HART®), pulse output, frequency output, and/or status output, limit switch and/or control input (depending on the I/O version)
Totaliser	2 (optional 3) internal totalisers with a max. of 8 counter places (e.g. for counting volume and/or mass units)
Verification	Integrated verification, diagnostic functions: measuring device, process, measured value, stabilisation
Concentration measurement	Universal concentration measurement, °Brix, °Baume, °Plato, alcohol concentration, NaOH and API density
Communication interfaces	HART®, Foundation Fieldbus, Profibus PA and DP, Modbus

Display and user interface	
Graphic display	LC display, backlit white.
	Size: 256 x 128 pixels, corresponds to 59 x 31 mm = 2.32" x 1.22"
	Display turnable in 90° steps.
	Ambient temperatures below -25°C / -13°F may affect the readability of the display.
Operating elements	4 push buttons/optical keys for operator control of the transmitter without opening the housing.
	Infrared interface for reading and writing all parameters with IR interface (option) without opening the housing.
Remote operation	PACTware™ (including Device Type Manager (DTM))
	HART® Hand Held Communicator from Emerson Process
	AMS® from Emerson Process
	All DTMs and drivers are available free of charge from the manufacturer's website.
Display functions	
Operating menu	Setting the parameters using 2 measuring pages, 1 status page, 1 graphic page (measured values and graphics are freely adjustable)
Language display texts	Available languages: English, German, French, Danish, Spanish, Italian, Dutch, Polish, Portuguese, Swedish, Turkish, Norwegian (check www.BuyAutomation.com for availability)
Measurement functions	Units: Metric, British and US units selectable as desired from lists for volume/mass flow and counting, velocity, temperature, pressure
	Measured values: Mass flow, total mass, temperature, density, volume flow, total volume, velocity, flow direction (not displayed unit – but available via outputs), Brix, Baume, NaOH, Plato, API, mass concentration, volume concentration
Diagnostic functions	Standards: VDI / NAMUR / WIB 2650 and NE 107
	Status messages: Output of status messages optional via display, current and/or status output, HART® or bus interface
	Sensor and sensor electronics diagnosis: Sensor signal integrity, sensor and drive coils diagnostics, measurement channels check, comparison of internal signals with references, drive circuit integrity, process temperature, CPU diagnostics, process temperature circuit monitoring, internal data integrity check, redundant calibration
	Transmitter and inputs/outputs: Data bus monitoring, current output connections, current readback with redundant calibration, factory calibration integrity, electronics temperature, CPU diagnostics, voltage monitoring

Measuring accuracy

Reference conditions	Medium: water
	Temperature: +20°C / +68°F
	Pressure: 1 bar / 14.5 psi
Maximum measuring error	Refer to technical data for the flow sensor.

Operating conditions

Temperature	
Process temperature	Refer to technical data for the flow sensor.
Ambient temperature	Depending on the version and combination of outputs. It is a good idea to protect the transmitter from external heat sources such as direct sunlight as higher temperatures reduce the life cycle of all electronic components.
	Die-cast aluminum housing: SIL device: -40...+55°C / -40...+131°F Non-SIL device: -40...+65°C / -40...+149°F
	Stainless steel housing: SIL device: -40...+55°C / -40...+131°F Non-SIL device: -40...+60°C / -40...+140°F
	Ambient temperatures below -25°C / -13°F may affect the readability of the display.
Storage temperature	-40...+70°C / -40...+158°F
Pressure	
Medium	Refer to technical data for the flow sensor.
Ambient pressure	Atmospheric
Chemical properties	
State of aggregation	Liquids, gases and slurries
Flow rate	Refer to technical data for the flow sensor.
Other conditions	
Ingress protection according to IEC 60529	IP66/67 (according to NEMA 4/4X)

Installation conditions

Installation	For detailed information, refer to chapter "Installation".
Dimensions and weight	For detailed information refer to chapter "Dimensions and weight".

Materials

Transmitter housing	Standard: die-cast aluminum (polyurethane coated)
	Option: stainless steel 316 / 1.4408
Flow sensor	For housing material, process connections, measuring tubes, accessories and gaskets, refer to technical data for the flow sensor.

Electrical connection

General	Electrical connection is carried out in conformity with the VDE 0100 directive "Regulations for electrical power installations with line voltages up to 1000 V" or equivalent national specifications.
Power supply	Standard: 100...230 VAC (-15% / +10%), 50/60 Hz
	Option: 24 VDC (-55% / +30%)
Power consumption	AC: 22 VA
	DC: 12 W
Signal cable	Only for remote versions.
	10 core shielded cable. Detailed specifications are available on request.
	Length: max. 20 m / 65.6 ft
Cable entries	Standard: M20 x 1.5 (8...12 mm)
	Option: 1/2 NPT, PF 1/2

Inputs and outputs

General	All outputs are electrically isolated from each other and from all other circuits. All operating data and output values can be adjusted.	
Description of abbreviations	U_{ext} = external voltage; R_L = load + resistance; U_0 = terminal voltage; I_{nom} = nominal current	
Current output		
Output data	Volume flow, mass flow, temperature, density, flow velocity, diagnostic values, 2-phase signal Concentration and concentration flow are also possible with available concentration measurement (optional).	
Resolution	<1 μ A	
Uncertainty	$\pm 5 \mu$ A	
Temperature coefficient	Typically ± 30 ppm/K	
Settings	Without HART®	
	Q = 0%: 0...20 mA; Q = 100%: 10...20 mA	
	Alarm signal: selectable 0...22 mA	
	With HART®	
	Q = 0%: 4...20 mA; Q = 100%: 10...20 mA Alarm signal: selectable 3...22 mA	
Operating data	Modular I/Os	Ex i
Active	$U_{int, nom} = 24$ VDC $I \leq 22$ mA $R_L \leq 1$ k Ω	$U_{int, nom} = 21$ VDC $I \leq 22$ mA $R_L \leq 400 \Omega$
		$I_0 = 90$ mA $P_0 = 0.5$ W $C_0 = 90$ nF / $L_0 = 2$ mH $C_0 = 110$ nF / $L_0 = 0.5$ mH
Passive	$U_{ext} \leq 30$ VDC $I \leq 22$ mA $U_0 \geq 1.8$ V $R_L \leq (U_{ext} - U_0) / I_{max}$	$U_{ext} \leq 30$ VDC $I \leq 22$ mA $U_0 \geq 4$ V $R_L \leq (U_{ext} - U_0) / I_{max}$
		$U_i = 30$ V $I_i = 130$ mA $P_i = 1$ W $C_i = 10$ nF $L_i \sim 0$ mH

HART®		
Description	HART® protocol via active and passive current output	
	HART® version: V7	
	Universal HART® parameter: completely integrated	
Load	≥ 230 Ω at HART® test point; Note maximum load for current output!	
Multi-Drop operation	Disabled loop current mode, output current = 0%, e.g. 4 mA	
	Multi-Drop address adjustable in operation menu 0...63	
Device drivers	Available for FC 375/475, AMS, FDT/DTM	
Registration (HART Communication Foundation)	Yes	
Pulse output or frequency output		
Output data	Pulse output: volume flow, mass flow, mass or volume of dissolved substance during activated concentration measurement	
	Frequency output: flow velocity, mass flow, temperature, density, diagnostic value Optional: concentration, flow of the dissolved substance	
Function	Can be set as a pulse output or frequency output	
Pulse rate/frequency	0.01...10000 pulses/s or Hz (5000 Hz for phase-shifted outputs)	
Settings	Mass or volume per pulse or max. frequency for 100% flow	
	Pulse width: adjustable as automatic, symmetric or fixed (0.05...2000 ms)	
Operating data	Modular I/Os	Fixed I/Os
Active	$U_{nom} = 24 \text{ VDC}$	-
	f_{max} in operating menu set to $f_{max} \leq 100 \text{ Hz}$: $I \leq 20 \text{ mA}$ open: $I \leq 0.05 \text{ mA}$ closed: $U_{0, nom} = 24 \text{ V}$ at $I = 20 \text{ mA}$	
	f_{max} in operating menu set to $100 \text{ Hz} <$ $f_{max} \leq 10 \text{ kHz}$: $I \leq 20 \text{ mA}$ open: $I \leq 0.05 \text{ mA}$ closed: $U_{0, nom} = 22.5 \text{ V}$ at $I = 1 \text{ mA}$ $U_{0, nom} = 21.5 \text{ V}$ at $I = 10 \text{ mA}$ $U_{0, nom} = 19 \text{ V}$ at $I = 20 \text{ mA}$	

Passive	$U_{ext} \leq 32 \text{ VDC}$	-
	f_{max} in operating menu set to $f_{max} \leq 100 \text{ Hz}$: $I \leq 100 \text{ mA}$ open: $I \leq 0.05 \text{ mA}$ at $U_{ext} = 32 \text{ VDC}$ closed: $U_{0, max} = 0.2 \text{ V}$ at $I \leq 10 \text{ mA}$ $U_{0, max} = 2 \text{ V}$ at $I \leq 100 \text{ mA}$	
	f_{max} in operating menu set to $100 \text{ Hz} <$ $f_{max} \leq 10 \text{ kHz}$: $I \leq 20 \text{ mA}$ open: $I \leq 0.05 \text{ mA}$ at $U_{ext} = 32 \text{ VDC}$ closed: $U_{0, max} = 1.5 \text{ V}$ at $I \leq 1 \text{ mA}$ $U_{0, max} = 2.5 \text{ V}$ at $I \leq 10 \text{ mA}$ $U_{0, max} = 5.0 \text{ V}$ at $I \leq 20 \text{ mA}$	
NAMUR	Passive to EN 60947-5-6 $U_{ext} = 8.2 \text{ V} \pm 0.1 \text{ VDC}$ $R = 1 \text{ k}\Omega \pm 10 \Omega$ open: $I_{nom} = 0.6 \text{ mA}$ closed: $I_{nom} = 3.8 \text{ mA}$	Passive to EN 60947-5-6 open: $I_{nom} = 0.43 \text{ mA}$ closed: $I_{nom} = 4.5 \text{ mA}$
		$U_i = 30 \text{ V}$ $I_i = 100 \text{ mA}$ $P_i = 1 \text{ W}$ $C_i = 10 \text{ nF}$ $L_i \sim 0 \text{ mH}$
Low flow cut off		
Function	Switching point and hysteresis separately adjustable for each output, counter and the display	
Switching point	Set in increments of 0.1%.	
	0...20% (current output, frequency output)	
Hysteresis	Set in increments of 0.1%.	
	0...20% (current output, frequency output)	
Damping		
Function	The time constant corresponds to the elapsed time until 63% of the end value has been reached according to a step function.	
Settings	Set in increments of 0.1 seconds.	
	0...100 seconds	

Status output / limit switch		
Function and settings	Adjustable as automatic measuring range conversion, display of flow direction, overflow, error or switching point.	
	Valve control with activated dosing function	
	Status and/or control: ON or OFF	
Operating data	Modular I/Os	Fixed I/Os
Active	$U_{int} = 24 \text{ VDC}$ $I \leq 20 \text{ mA}$ open: $I \leq 0.05 \text{ mA}$ closed: $U_{0, nom} = 24 \text{ V at } I = 20 \text{ mA}$	-
Passive	$U_{ext} \leq 32 \text{ VDC}$ $I \leq 100 \text{ mA}$ $R_{L, max} = 47 \text{ k}\Omega$ $R_{L, min} = (U_{ext} - U_0) / I_{max}$ open: $I \leq 0.05 \text{ mA at } U_{ext} = 32 \text{ VDC}$ closed: $U_{0, max} = 0.2 \text{ V at } I \leq 10 \text{ mA}$ $U_{0, max} = 2 \text{ V at } I \leq 100 \text{ mA}$	-
NAMUR	Passive to EN 60947-5-6 $U_{ext} = 8.2 \text{ V} \pm 0.1 \text{ VDC}$ $R = 1 \text{ k}\Omega \pm 10 \Omega$ open: $I_{nom} = 0.6 \text{ mA}$ closed: $I_{nom} = 3.8 \text{ mA}$	Passive to EN 60947-5-6 open: $I_{nom} = 0.43 \text{ mA}$ closed: $I_{nom} = 4.5 \text{ mA}$ $U_i = 30 \text{ V}$ $I_i = 100 \text{ mA}$ $P_i = 1 \text{ W}$ $C_i = 10 \text{ nF}$ $L_i = 0 \text{ mH}$

Control input		
Function	Hold value of the outputs (e.g. for cleaning work), set value of the outputs to "zero", counter and error reset, stop counter, range conversion, zero calibration	
	Start of dosing when dosing function is activated.	
Operating data	Modular I/Os	Fixed I/O
Active	$U_{int} = 24 \text{ VDC}$ External contact open: $U_{0, nom} = 22 \text{ V}$ External contact closed: $I_{nom} = 4 \text{ mA}$ Contact open (off): $U_0 \geq 12 \text{ V}$ with $I_{nom} = 1.9 \text{ mA}$ Contact closed (on): $U_0 \leq 10 \text{ V}$ with $I_{nom} = 1.9 \text{ mA}$	-
Passive	$3 \text{ V} \leq U_{ext} \leq 32 \text{ VDC}$ $I_{max} = 9.5 \text{ mA}$ at $U_{ext} \leq 24 \text{ V}$ $I_{max} = 9.5 \text{ mA}$ at $U_{ext} \leq 32 \text{ V}$ Contact closed (on): $U_0 \geq 3 \text{ V}$ with $I_{nom} = 1.9 \text{ mA}$ Contact open (off): $U_0 \leq 2.5 \text{ V}$ with $I_{nom} = 1.9 \text{ mA}$	$U_{ext} \leq 32 \text{ VDC}$ $I \leq 6 \text{ mA}$ at $U_{ext} = 24 \text{ V}$ $I \leq 6.5 \text{ mA}$ at $U_{ext} = 32 \text{ V}$ On: $U_0 \geq 5.5 \text{ V}$ with $I \geq 4 \text{ mA}$ Off: $U_0 \leq 3.5 \text{ V}$ with $I \leq 0.5 \text{ mA}$ $U_i = 30 \text{ V}$ $I_i = 100 \text{ mA}$ $P_i = 1 \text{ W}$ $C_i = 10 \text{ nF}$ $L_i = 0 \text{ mH}$
NAMUR	Active to EN 60947-5-6 Terminals open: $U_{0, nom} = 8.7 \text{ V}$ Contact closed (on): $U_{0, nom} = 6.3 \text{ V}$ with $I_{nom} > 1.9 \text{ mA}$ Contact open (off): $U_{0, nom} = 6.3 \text{ V}$ with $I_{nom} < 1.9 \text{ mA}$ Detection of cable break: $U_0 \geq 8.1 \text{ V}$ with $I \leq 0.1 \text{ mA}$ Detection of cable short circuit: $U_0 \leq 1.2 \text{ V}$ with $I \geq 6.7 \text{ mA}$	-

Profibus DP	
Description	Galvanically isolated according to IEC 61158, test voltage 500 VAC RMS
	Profile version: 3.02
	Automatic data transmission rate recognition (max. 12 MBaud)
	Bus address adjustable via local display at the measuring device
Function blocks	8 x analogue input (AI), 3 x totaliser
Output data	Mass flow, volume flow, mass counter 1 + 2, volume counter, product temperature, several concentration measurements and diagnostic data
Profibus PA	
Description	Galvanically isolated according to IEC 61158, test voltage 600 VAC RMS for Ex i I/O, 500 VAC RMS for other I/O
	Profile version: 3.02
	Current consumption: 10.5 mA
	Permissible bus voltage: 9...32 V; in Ex application: 9...24 V
	Bus interface with integrated reverse polarity protection
	Typical error current FDE (Fault Disconnection Electronic): 4.3 mA
	Bus address adjustable via local display at the measuring device
Function blocks	8 x analogue input (AI), 3 x totaliser
Output data	Mass flow, volume flow, mass counter 1 + 2, volume counter, product temperature, several concentration measurements and diagnostic data
Foundation Fieldbus	
Description	Galvanically isolated according to IEC 61158, test voltage 600 VAC RMS for Ex i I/O, 500 VAC RMS for other I/O
	Current consumption: 10.5 mA
	Permissible bus voltage: 9...32 V; in Ex application: 9...24 V
	Bus interface with integrated reverse polarity protection
	Link Master function (LM) supported
	Tested with Interoperable Test Kit (ITK) version 6.01
Function blocks	6 x analogue input (AI), 2 x integrator, 1 x PID
Output data	Mass flow, volume flow, density, temperature of tube, several concentration measurements and diagnostic data
Modbus	
Description	Galvanically isolated, test voltage 500 VAC RMS
	Modbus RTU over RS-485
	Receiver input tolerance (baud rate deviation): 3%
	RS-485 receiver input resistance: 96 k Ω = 1/8 unit load
	RS-485 driver short-circuit output current: 200 mA
	Optionally switchable bus termination: 136 Ω , 0.5 W
	Optionally switchable bus polarisation: 2 x 562 Ω , 0.2 W
Modbus device DTM is available which allows easy and comfortable communication with the transmitter.	
Address range	1...255

Supported function codes	01, 02, 03, 04, 05, 06, 08, 15, 16, 23, 43
Baud rates	1200...115200

Approvals and certificates

CE	<p>This device fulfils the statutory requirements of the relevant EU directives. The manufacturer certifies successful testing of the product by applying the CE mark.</p> <p>For full information of the EU directives & standards and the approved certifications, please refer to the CE declaration or the manufacturer website.</p>
Non-Ex	Standard
Functional safety according to EN 61508	Depends on I/O variant and flow sensor. For detailed information refer to the "Safety manual".
Hazardous areas	
Option (C version only)	
ATEX	II 1/2 (1) G Ex db ia [ia Ga] IIC T6...T1 Ga/Gb
	II 1/2 (1) G Ex db eb ia [ia Ga] IIC T6...T1 Ga/Gb
	II 2 (1) D Ex tb [ia Da] IIIC Txxx°C Db
	II 1/2 G Ex db ia IIC T6...T1 Ga/Gb; II 1/2 G Ex db eb ia IIC T6...T1 Ga/Gb
	II 2 D Ex tb IIIC Txxx°C Db
Option (F version only)	
ATEX	II 2 (1) G Ex db [ia Ga] IIC T6 Gb
	II 2 (1) G Ex db eb [ia Ga] IIC T6 Gb
	II 2 (1) D Ex tb [ia Da] IIIC T75°C Db
	II 2 G Ex db [ia] IIC T6 Gb
	II 2 (1) D Ex tb [ia Da] IIIC T75°C Db
	II 2 D Ex tb IIIC T75°C Db
	II 2 G Ex db eb [ia] IIC T6 Gb
	II 2 D Ex tb IIIC T75°C Db
NEPSI	Ex d ia [ia Ga] IIC T6...T1 Ga/Gb; Ex de ia [ia Ga] IIC T6...T1 Ga/Gb
Option	
cFMus	FM: Class I, Div 1 groups A, B, C, D FMc: Class I, Div 1 groups C, D
	Class II, Div 1 groups E, F, G
	Class III, Div 1 hazardous areas
	FM: Class I, Div 2 groups A, B, C, D FMc: Class I, Div 2 groups A, B, C, D
	Class II, Div 2 groups F, G
	Class III, Div 2 hazardous areas
IECEx	Ex zone 1 + 2
Other standards and approvals	
Vibration resistance	IEC 60068-2-6 10 cycles 10-150-10 Hz with: 0.15 mm for 10-60 Hz and 20 m/s ² for 60-150 Hz
NAMUR	NE 21, NE 43, NE 53, NE 107

2.2 Dimensions and weight

2.2.1 Housing

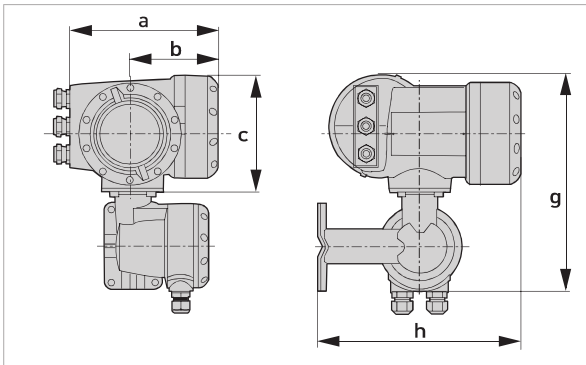

Figure 2-1: Dimensions for field housing (F) - remote version

Dimensions [mm / inch]					Weight [kg / lb]	
a	b	c	g	h	Aluminum housing	Stainless steel housing
202 / 7.95	120 / 4.72	155 / 6.10	296 / 11.65	277 / 10.90	6 / 13.2	13 / 28.7

Table 2-1: Dimensions and weight of field housing

The total dimensions and weight of the compact device are depending on the nominal diameter and the material of the flow sensor.

For detailed information please refer to the relevant flow sensor documentation.

2.2.2 Mounting plate of field housing

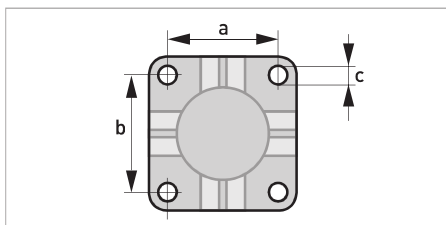

Figure 2-2: Dimensions for mounting plate of field housing

	[mm]	[inch]
a	72	2.8
b	72	2.8
c	Ø9	Ø0.4

Table 2-2: Dimensions in mm and inch

Model	Description
34	Model CFT34A Coriolis Flow Transmitter
4 H S T	Type Compact version Field housing - remote version Spare converter insert (supplied unconfigured) Spare converter insert (supplied configured)
1 4 A	Power supply 12 - 24 V DC (12 - 24 VDC) 24 V DC / AC (19 - 29 V) 100 - 230V AC (85-250 V AC, 50/60 Hz)
0 1 2 7 A B D E F G N P	Hazardous area approvals Without - non Ex or spare converter Insert ATEX Ex zone 1 ATEX Ex zone 1 cFMus Class 1, Div 1 Non Ex (USA) Non Ex (Canada) INMETRO Brazil only INMETRO Brazil only IEC Ex IEC Ex NEPSI NEPSI
0 4 5 6 R	Cable connection Default 1/2" NPT adaptors made of metal (mandatory for cFMus / option for ATEX) (3x compact / 5x remote) 3 x 3 x SS316 1/2" NPT adaptors (2x compact / 4x remote) plus blanking plug
1 2 4 8	Instruction manual / Operating language German English French Spanish
0 S	Special functions Without SIL (for compliant sensors only)
0 1 2 3 A B C	Transmitter housing Without (for spare part electronics only) Standard St. st. 1.4404 (for compact) St. st. 1.4404 (for field) Standard Aluminium with polycarbonate window St. st. 1.4404 (for compact) with polycarbonate window St. st. 1.4404 (for field) with polycarbonate window

Model	Description
	Outputs Base Module Modular
4	Modular - Option Modular IO: CO act. + PO act./hc (CO-active+PO-active/high current)
6	Modular IO: CO act. + PO pas./hc (CO-active+PO-passive/high cur.)
7	Modular IO: CO act. + PO pas./Na (CO-active+PO-passive/Namur)
8	Modular IO: CO pas. + PO act./hc (CO-passive+PO-active/high cur.)
B	Modular IO: CO pas. + PO pas./hc (CO-passive+PO-passive/high cur.)
C	Modular IO: CO pas. + PO pas./Na (CO-passive+PO-passive/Namur)
D	Fieldbus IO: Profibus PA, Non FISCO
E	Fieldbus IO: Foundation Fieldbus, Non FISCO
F	Fieldbus IO: Profibus DP, Non FISCO
G	RS 485 Modbus
N	Ethernet - PROFINET (not for hazardous area applications)
2	Fixed - Option Ex-ia IO: CO act. + PO pas. (CO-active+PO-passive)
3	Ex-ia IO: CO pas. + PO pas. (CO-passive+PO-passive)
D	Ex-I Fieldbus IO: Profibus PA, FISCO
E	Ex-I Fieldbus IO: Foundation Fieldbus, FISCO
	Outputs 1st I/O Module
0	Modular - Option Without
8	Without IO module
A	Current Output - active
B	Current Output - passive
C	Pulse Output - active / high current
E	Pulse Output - passive / high current
F	Pulse Output - passive / Namur
G	Control Input - active / high current
H	Control Input - active / Namur
K	Control Input - passive / high current
0	Fixed - Option Without, no module possible
1	Ex-ia IO: CO act. + PO / CI pas. (CO-active+PO/Control Input-pas.)
2	Ex-ia IO: CO pas. + PO / CI pas. (CO-passive+PO/Control Input-pas.)
	Outputs 2nd I/O Module
0	Modular - Option Without
8	Without IO module
A	Current Output - active
B	Current Output - passive
C	Pulse Output - active / high current
E	Pulse Output - passive / high current
F	Pulse Output - passive / Namur
G	Control Input - active / high current
H	Control Input - active / Namur
K	Control Input - passive / high current
0	Fixed - Option Without, no module possible

Model	Description
0 1 2 3 4 5 6 A B	Measuring functions Standard (mass,density,temp.,vol.) Standard + Brix Standard + General concentration Standard + Baume 144.3 Standard + Baume 145 Standard + NaOH Standard + Plato Standard + API oil standard Standard + Alcohol
0 1 W	Manuals Standard Set paper manuals Without CD or paper manuals
0 4 1 6 5	Remote option signal cable None required 5m/15ft 10m/30ft 15m/45ft 20m/60ft

ORDERING INSTRUCTIONS

1. Model Number.
2. Flow Data:
 - a. Maximum, minimum, and normal flow rate.
 - b. Fluid composition and viscosity at operating temperatures.
 - c. Fluid density or relative density (specific gravity).
 - d. Maximum, minimum and normal operating temperatures.
 - e. Maximum, minimum and normal operating pressures.
 - f. Mating pipe schedule.
 - g. Type and location (distance) of upstream disturbance.
3. Calibration Information (analog output only); maximum flow rate 20 mA output.
4. Electric Classification.
5. Optional Selections and Accessories.
6. Customer Tag Data.

FLOWEXPERTPRO SIZING APPLICATION

Website
www.FlowExpertPro.com



App Store (Apple®)



Google Play™ Store
(Android®)



ADDITIONAL PRODUCTS

These product lines offer a broad range of measurement and instrument products, including solutions for pressure, flow, analytical, temperature, positioning, controlling and recording.

For a list of these offerings, visit our website at:
www.se.com

Schneider Electric Systems USA, Inc.
70 Mechanic Street
Foxboro MA 02035-2037
United States of America
<http://www.se.com>

Global Customer Support
Inside U.S.: 1-866-746-6477
Outside U.S.: 1-508-549-2424
<https://pasupport.schneider-electric.com>

Copyright 2020 Schneider Electric Systems USA, Inc.
All rights reserved.

The Schneider Electric brand and any trademarks of Schneider Electric SE or its subsidiaries are the property of Schneider Electric SE or its subsidiaries. All other trademarks are the property of their respective owners.