

- For continuous level measurement of liquids (even if polluted), mash and paste materials in open or closed vessels, sumps, open channels, etc.
- Configuration and adjustment of measuring range by two buttons
- Xi version for usage in explosive areas
- State indication by two LEDs
- Current (4 ... 20 mA) or voltage (0 ... 10 V) output
- Options of inverse function (20 ... 4 mA or 10 ... 0V)



Ultrasonic level meters ULM[®] is self contained device that includes electroacoustics transducer and electronic module. The level meter ULM transmits series of ultrasonic pulses which propagates towards the liquid surface. Reflected acoustic wave is received back in the ULM transducer and processed in electronic module. The distance calculations are based on time of flight of the acoustic wave to the level and back.

The level meters are suited to level measurement of various liquid materials, sewerage waters, mash and paste materials, suspensions etc. In case the level of bulk-solid materials is measured, the measurement range is reduced. We recommend to consult the use with the manufacturer.

All the setting is done by means of two buttons, located in the upper part of the sensor. Level meters are equipped with optimal state indication "STATE" and the setting process "MENU". The level meters outputs can be current or voltage.

FEATURES OF VARIANTS

- **ULM-53_-02_-** *measuring range from 0.25 m to 2 m*, plastic PVDF transmitter and plastic body (PP+HDPE), process connection with thread G 1".
- **ULM-53_-06_-** *measuring range from 0.25 m to 6 m*, plastic PVDF transmitter and plastic body (PP+HDPE), process connection with thread G 1 ½".
- **ULM-53_-10_-** *measuring range from 0.5 m to 10 m*, plastic PVDF transmitter and plastic body (PP+HDPE), aluminium alloy ("Xi" version) or HDPE ("N" version) flange.
- **ULM-53_-20_-** *measuring range from 0.5 m to 20 m*, with plastic PVDF transmitter and plastic body (PP+HDPE), aluminium alloy flange.

DIMENSIONAL DRAWINGS

ULM-53_02_

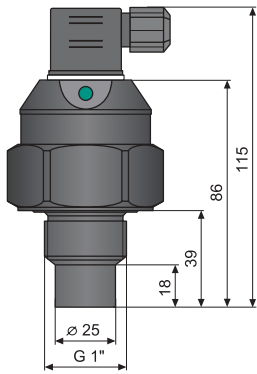

ULM-53_06_

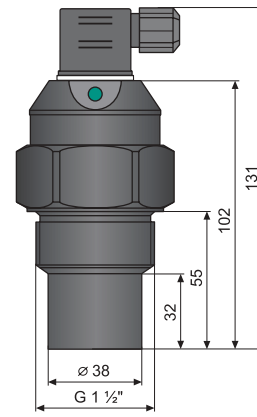

ULM-53N-10_

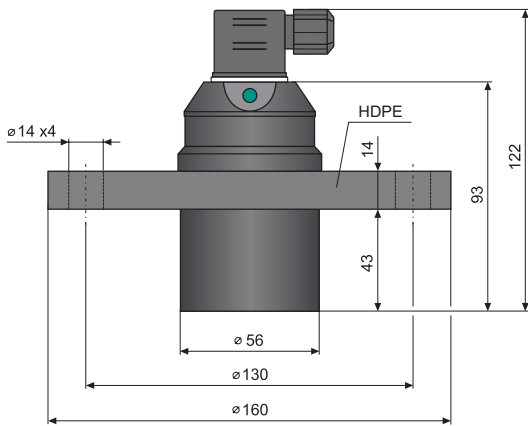

ULM-53Xi-10-I

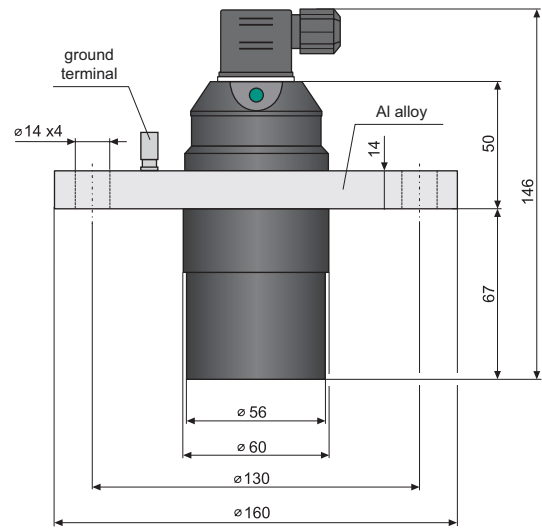

ULM-53_20_

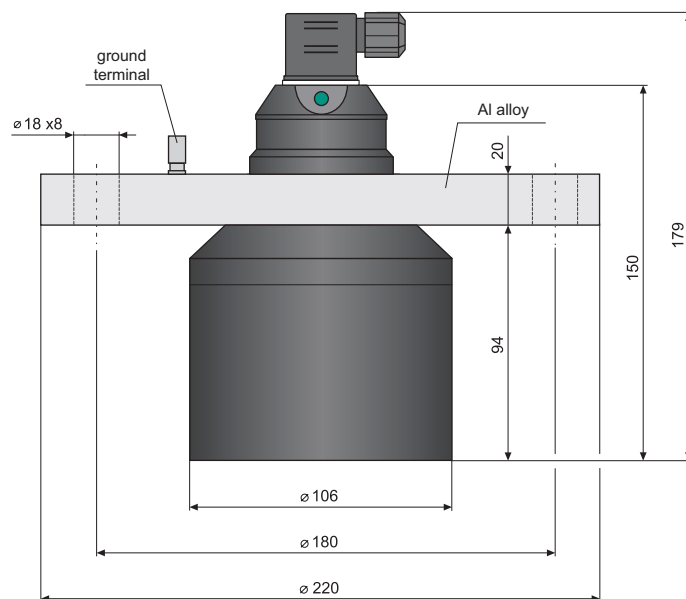

TECHNICAL SPECIFICATIONS

Measuring range ¹⁾	ULM-53_-02-_	0.25 ... 2 m
	ULM-53_-06-_	0.25 ... 6 m
	ULM-53_-10-_	0.5 ... 10 m
	ULM-53_-20-_	0.5 ... 20 m
Supply voltage	ULM-53N-__-__	18 ... 36 V DC
	ULM-53Xi-__-I	18 ... 30 V DC
Current output ULM-53_-__-I Voltage output ULM-53N-__-U		4 ... 20 mA (limit values 3.9 ... 20.5 mA) 0 ... 10 V (limit values 0 ... 10.2 V)
Resolution		< 1 mm
Accuracy (within the total range)	ULM-53_-06-_ ; 10-_ ; 20-_	0.2 %
	ULM-53_-02-_	0.3 %
Temperature error		max. 0.04% / K
Beamwidth (-3 dB)	ULM-53_-02-_ ; 10-_	10°
	ULM-53_-06-_	14°
	ULM-53_-20-_	12°
Ambient temperature range	ULM-53_-02-_ ; 06-_	-30 ... +70°C
	ULM-53_-10-_ ; 20-_	-30 ... +60°C
Measuring period	ULM-53_-02-_	0.6 sec.
	ULM-53_-06-_	1.4 sec.
	ULM-53_-10-_	1.8 sec.
	ULM-53_-20-_	5.0 sec.
Averaging (can be modified according to agreement)		8 measuring
Short time temperature stress resistance		+90°C / 1 hour
Max. operation overpressure (on transmission surface)		0.1 MPa
Max. internal values ²⁾ (for the Xi version only)		U _i =30V DC; I _i =132mA; P _i =0.99W; C _i =370nF; L _i =0.9mH
Failure indication	echo failure – basic mode	3.75 mA (0 V)
	echo failure – inverse mode	22 mA (10.5 V)
	level in dead zone – basic mode	22 mA (10.5 V)
	level in dead zone – inverse mode	3.75 mA (0 V)
Protection class		IP67
Recommended cable		PVC 2 x 0.75 mm ² (3 x 0.5 mm ²)
Current output load resistance (at U = 24 V DC)		R _{max} = 270 Ω
Voltage output load resistance		R > 1 kΩ
Delay between supply power rise time and first measurement	ULM-53_-02-_ ; 06-_ ; 10-_	3 sec.
	ULM-53_-20-_	5 sec.
Delay between power supply rise time and full emission output	ULM-53_-02-_ ; 06-_ ; 10-_	30 sec.
	ULM-53_-20-_	45 sec.
Weight	ULM-53_-02-_	0.20 kg
	ULM-53_-06-_	0.25 kg
	ULM-53_-10-_	0.65 kg
	ULM-53_-20-_	2.80 kg

¹⁾ In case the level of bulk-solid materials is measured, the measurement range is reduced.

²⁾ Allowed temperature range in the zone 0: -20°C ... +60°C; allowed pressure range in the zone 0: 80 ... 110 kPa.

AREA CLASSIFICATION (according to EN 60079-10 and EN 60079-14)

ULM-53N-__-__	Performance for non-explosive areas
ULM-53Xi-02-I ULM-53Xi-06-I	Explosive proof – suitable for explosive areas (combustible gases or vapours) ⊕ II 1/2G Ex ia IIB T5 with isolating repeater (IRU-420) the whole level meter – zone 1, front head part – zone 0
ULM-53Xi-10-I	Explosive proof – suitable for explosive areas (combustible gases or vapours) ⊕ II 1/2G Ex ia IIA T5 with isolating repeater (IRU-420) the whole level meter – zone 1, front head part – zone 0
ULM-53Xi-20-I	Explosive proof – suitable for explosive areas (combustible gases or vapours) ⊕ II 2G Ex ia IIA T5 with isolating repeater (IRU-420) the whole level meter – zone 1

INSTALLATION

Level meter is installed into the upper lid of the tank (vessel), using a fixing nut or a flange.

If installed in an open channel (sumps, reservoirs, etc.), install the level meter as closest as you can to the maximum level expected.

The front of the level meter must run in parallel to the measured level.

Emitted acoustic signal must not be affected by near objects (stiffeners, ladders, mixers, unevenness, etc.), stream of filling, air flow, etc.

Foam on the level absorbs the acoustic wave reflection which might cause malfunction of the level meter. If possible select the location where the foaming is as low as possible.

Protect the level meter against direct sunlight.

In the case of uncertainty we recommend to consult the application with the producer.

MOUNTING RECOMMENDATION

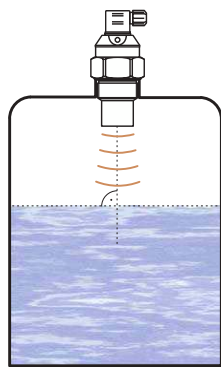

Recommended installation

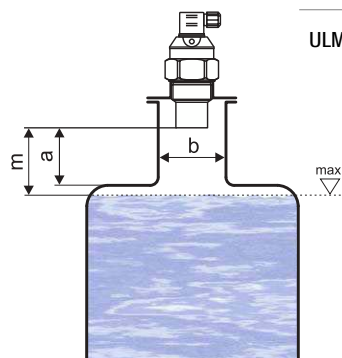

ULM-53-02; 06	$a < 3b$ $b > 100\text{ mm}$
ULM-53-10	$a < 1,5b$ $b > 100\text{ mm}$
ULM-53-20	$a < 1,5b$ $b > 150\text{ mm}$

a - neck height
b - neck width
m - dead zone

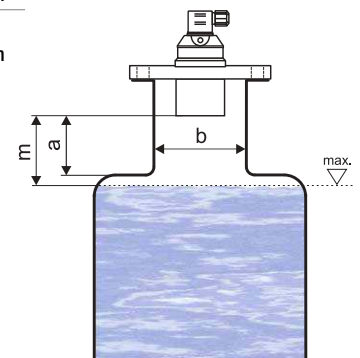

Possible installation through the neck

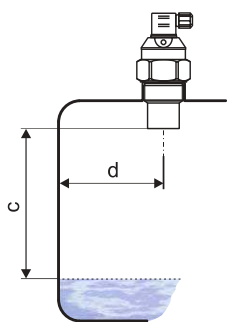

c - measuring range
d - min. distance from tank wall

ULM-53-02; 10	$d > 1/12 c$ (min. 200 mm)
ULM-53-06	$d > 1/8 c$ (min. 200 mm)
ULM-53-20	$d > 1/10 c$ (min. 200 mm)

Installation distance from the tank wall

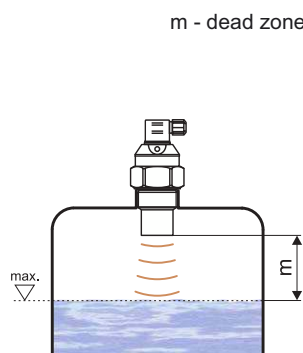

m - dead zone

Maximum level distance from ULM

ELECTRICAL CONNECTION

The ultrasonic level meter is designed to be connected to supply unit or to controller through two or three-wire cable with outer diameter $6 \div 8$ mm (recommended cross section of cores 0,5 to 0,75 mm²) by means of connector which is included in delivery. Connection diagram and inner view of the connector as shown in picture. Always disconnect the power supply before connecting the level meter electrically!

Note: In case of strong electromagnetic interferences (EMI), parallel cable ducting with power lines, or when cable length exceeds 30 m we recommended to use shielded cable.

WARNING:

With regard to possible occurrence of electrostatic charge on non-conductive parts of the level meter, metallic flanges of the ULM-53Xi-10-I and ULM-53Xi-20-I (for explosive areas) level meters must be grounded with ground terminal!

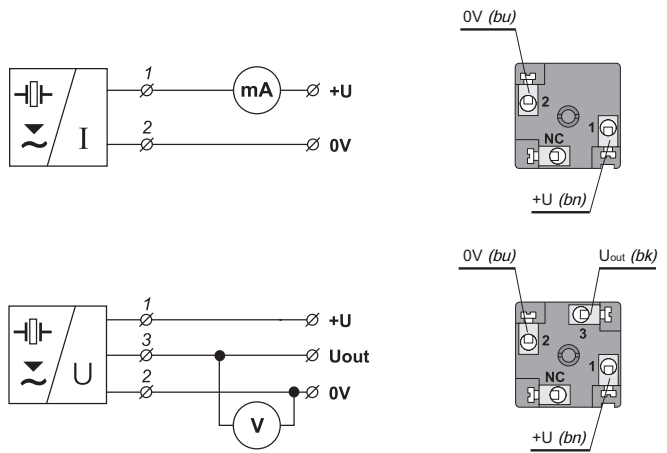

Connection scheme

The inside of the connector socket

coments:

bk – black
bu – blue

bn – brown
NC – not connected

LEVEL METER SETTING

The measuring range is setup by means of two buttons "DOWN" and "UP". The "DOWN" button is used to enter to the setting mode (setting the 4 mA or 0 V limit) and to decrease the output current or voltage. The "UP" button as an opposite function (setting the 20 mA or 10 V limit and increasing the output current or voltage). Values are confirmed by simultaneous pressing of both buttons for about 1 sec. The setting process is indicated by yellow "MENU" LED indicator.

For detailed information please read at the instructions manual.



Full view of ultrasonic level meter

STATUS AND FAILURE SIGNALIZATION

LED indicators	colour	function
"STATE"	green	Slow flashing (1–2 sec. depends on the measuring interval) – reception of reflected signal (echo) from the measured level. Correct function. Fast blinks – the measured value is in "dead zone" of the level meter, or the ultrasonic transm. is polluted. Dark – the measured value is in "dead zone" of the level meter, or the ultrasonic transm. is polluted. Incorrect installation or malfunction.
"MENU"	yellow	Slow blinks – signalization setting limit 4 mA Fast blinks – signalization setting limit 20 mA

RANGE OF APPLICATION

For continuous non-contact level measurement of liquids (water solutions, sewerage water, etc.), mash and paste materials (sediments, sticks, resins etc.) in closed or open vessels, sumps, reservoirs and open channels.

In case the level of bulk-solid materials is measured, the measurement range is reduced. We recommend to consult the use with the manufacturer.

ORDER CODE

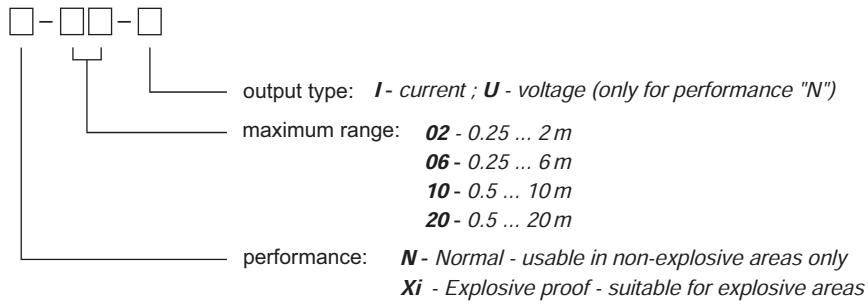

CORRECT SPECIFICATION EXAMPLES

ULM-53N-02-I
ULM-53Xi-06-I

ULM-53N-10-U
ULM-53Xi-20-I

ACCESSORIES

standard – included in the level meter price

1x of seal (only for ULM-53_-02; 06-_)
1x connector socket

optional – for extra charge

stainless fixing nut UM-G1" (for ULM-53_-02-_)
stainless fixing nut UM-G1 ½" (for ULM-53_-06-_)

SAFETY, PROTECTIONS, COMPATIBILITY AND EXPLOSION PROOF

The level meter ULM-53 is equipped with protection against reverse polarity and output current overload. Protection against dangerous contact is secured by low safety voltage that complies with EN 33 2000-4-41.

Electromagnetic compatibility according to EN 55022/B, EN 61326/Z1 and EN 61000-4-2 to 6.

Explosion proof of ULM-53Xi type complies with the following standards: EN 60079-0 : 2007;
EN 60079-11 : 2007 ; EN 60079-26 : 2007 and examined by FTZÚ-AO 210 Ostrava - Radvanice certif. No.: FTZÚ 09 ATEX 0119X.