

- Célula de carga de tracción/compresión
- 3000 divisiones O.I.M.L. R60 clase C
- Soporte elástico de acero aleado
- Protección IP 67 (EN 60529)
- Tratamiento anticorrosión de níquel duro
- Aplicaciones:
 - Tanques, Tolvas y Cintas pesadoras suspendidas de estructuras
 - Centrales de asfalto y hormigón
 - Medida de fuerza en maquinaria de ensayo
 - Pesaje aéreo

- Tension/compression load cell
- 3000 divisions O.I.M.L. R60 class C
- Measuring element from Steel alloy
- Protected IP 67 (EN 60529)
- Protected against corrosion by nickel-plated treatment
- Applications:
 - Suspended weighing in Tanks, Hoppers and Belt Conveyor Scales
 - Asphalt and Concrete Plants
 - Force measurement in Test Equipment
 - Crane scales

Modelo Model	Carga nominal Nominal capacity Ln	Clase de precisión Accuracy class n. OIML	División mínima Minimum division vmin	Carga de servicio Service load	Carga límite Safe load
610 50 kg	50 kg	3000	5 g	75 kg	150 kg
610 100 kg	100 kg	3000	10 g	150 kg	300 kg
610 250 kg	250 kg	3000	25 g	375 kg	750 kg
610 500 kg	500 kg	3000	50 g	750 kg	1500 kg
610 1000 kg	1000 kg	3000	100 g	1200 kg	2000 kg

MODELO 610

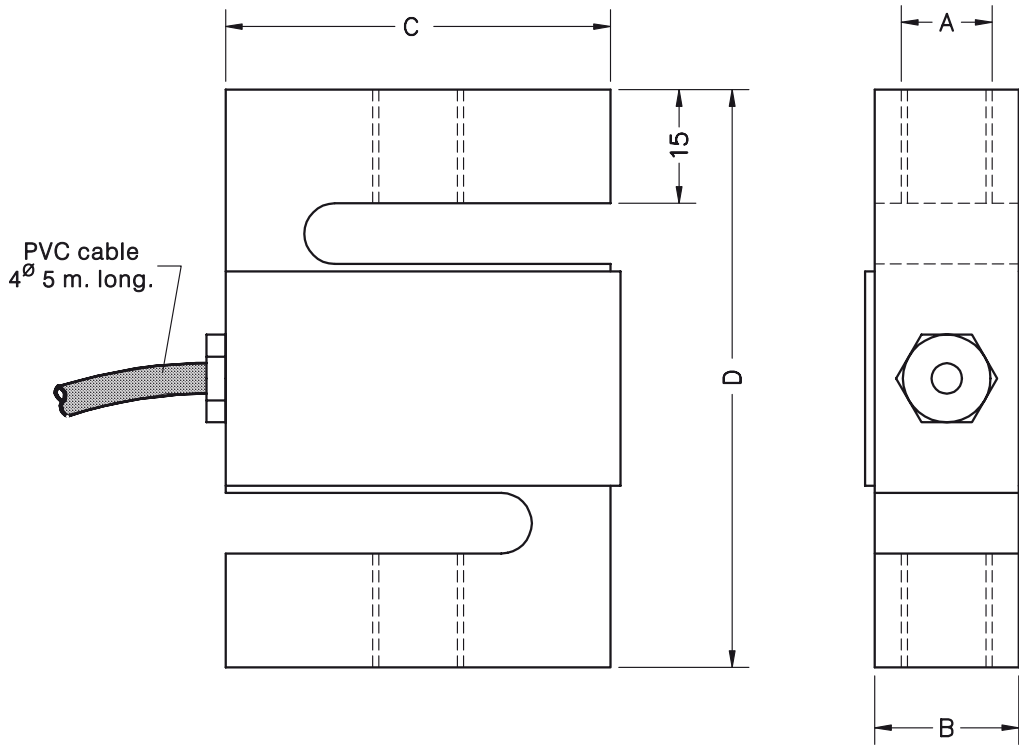

Carga nominal Nominal load	A	B	C	D	Peso transporte Transport weight
50-100 kg	M10x1.5	15	50.8	76.2	0.5 kg
250-500 kg	M12x1.75	19	50.8	76.2	0.6 kg
1000 kg	M12x1.75	25	49.5	75.0	0.7 kg

Dimensiones en mm. *Dimensions in mm.*

ESPECIFICACIONES			SPECIFICATIONS
Cargas nominales (Ln)	50-100-250-500-1000	kg	Nominal capacities (Ln)
Clase de precisión	3000	n. OIML	Accuracy class
Carga mínima	0	%Ln	Minimum dead load
Carga de servicio	150	%Ln (1)	Service load
Cargas límite	300	%Ln (2)	Safe load limit
Error combinado	< ±0.017	%Sn	Total error
Error repetibilidad	< ±0.015	%Sn	Repeatability error
Efecto de la temperatura: en el cero	< ±0.01	%Sn/5°K	Temperature effect: on zero
en la sensibilidad	< ±0.006	%Sn/5°K	on sensitivity
Error de fluencia (30 minutos)	< ±0.016	%Sn	Creep error (30 minutes)
Compensación de temperatura	-10...+40	°C	Temperature compensation
Límites de temperatura	-30...+70	°C	Temperature limits
Sensibilidad nominal (Sn)	3 ±0.25%	mV/V	Nominal sensitivity (Sn)
Tensión de alimentación nominal	10	V	Nominal input voltage
Tensión de alimentación máxima	15	V	Maximum input voltage
Resistencia de entrada	400 ±20	Ω	Input impedance
Resistencia de salida	350 ±3	Ω	Output impedance
Desequilibrio inicial	< ±2	%Sn	No load output
Resistencia de aislamiento	> 5000	MΩ	Insulation resistance
Deformación máxima (a Ln)	0.3-0.5	mm	Maximum deflection (at Ln)

CONEXION ELECTRICA ELECTRICAL CONNECTION:

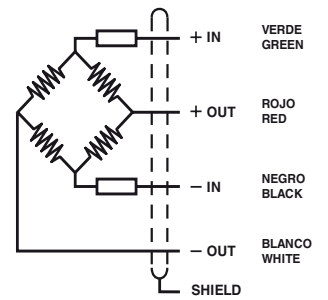

«CONVENIO SIGNOS SALIDA PARA TRACCIÓN»

«OUTPUT SIGNS FOR TENSION APPLICATION»

(1) Para 1000 kg: 120% / For 1000 kg: 120 %

(2) Para 1000 kg: 200 % / For 1000 kg: 200%

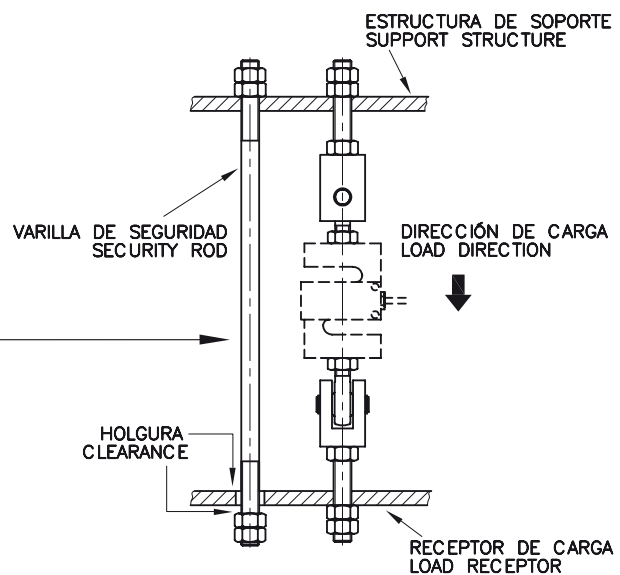
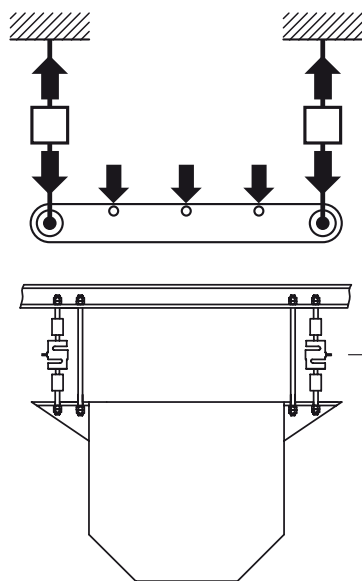
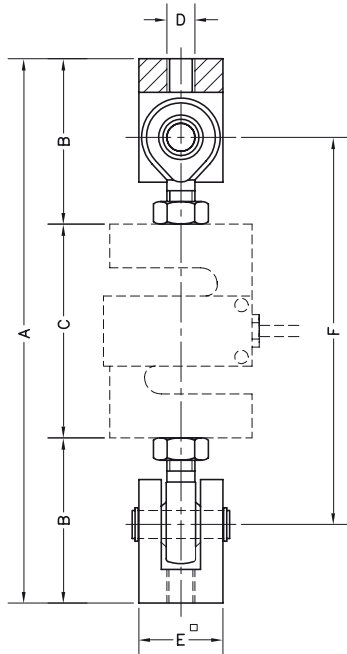
ACCESORIO TRACCION PARA MOD. 610
TENSION ACCESSORY FOR MODEL 610

Accesorio Accessory	Carga nominal Nominal load	A	B	C	D	E [□]	F	Carga límite Ultimate load	Peso transporte Transport weight	Material
TE10x1.5	50-100 kg	194	58.9	76.2	M10x1.5	30	138	400 kg	0.7 kg	Acero cincado
TE12x1.75	250...1000 kg	242.2	83	76.2	M12x1.75	35	154.2	2580 kg	1.4 kg	Steel zinc-plated

Dimensiones en mm. *Dimensions in mm.*

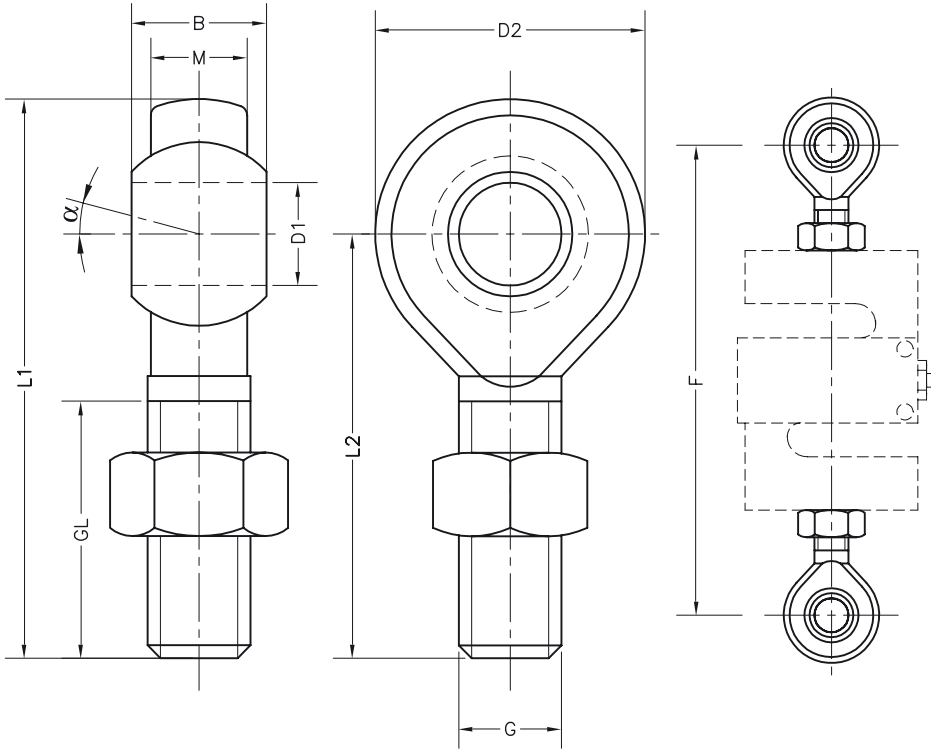
ROTULAS PARA EL MODELO 610
ROD ENDS FOR MODEL 610

- **Material: Acero cincado**
- **Cada accesorio RO contiene un juego de: 2 rótulas y 2 tuercas**

- **Material: Steel zinc-plated**
- **Each accessory RO includes a set of: 2 rod ends and 2 nuts**

Dimensiones Accesorios RO/ RO Accessories Dimensions												
Accesorio Accessory	Capacidad/ Capacity (kg)	D2	B	M	D1	L1	L2	GL	G	α	F	Peso transp. Trans. weight
RO10x1.5	50-100	28	14	10.5	Ø10	62	48	29	M10x1.5	13°	138	0.2 kg
RO12x1.75	250-500-1000	32	16	12.0	Ø12	70	54	33	M12x1.75	13°	154.2	0.2 kg

Dimensiones en mm. *Dimensions in mm.*