



## ULTRASONIC LEVEL METERS ULM-53

---



# CONTENT

---

- Safety ..... 3
- Measuring principle..... 3
- Range of application ..... 3
- Features of variants ..... 3
- Dimensional drawings ..... 4
- Installation instructions ..... 5
- Electrical connection ..... 8
- Set-up elements..... 8
- Status and failure signalization..... 9
- Operational modes ..... 9
- Setting up ..... 9
- Order code ..... 11
- Accessories ..... 11
- Safety, protection, compatibility and explosion proof..... 11
- Use, manipulation and maintenance ..... 11
- Marking of labels..... 12
- Technical specifications..... 16
- Area classification..... 17

## SAFETY

All operations described in this instruction manual have to be carried out by trained personnel or by an accredited person only. Installation, commissioning, operation and maintenance of the ultrasonic level meters has to be carried out in accordance with this instruction manual; the provisions of regulations in force regarding the installation of electrical equipment have to be adhered to.

Improper use, installation or set-up of the sensor can lead to crashes in the application, (overfilling of the tank or damage of system components).

The manufacturer is not responsible for improper use, loss of work caused by either direct or indirect damage, and for expenses incurred at the time of installation or during the period of use of the sensor.

Customer service must be carried out by the manufacturer exclusively.

---

## MEASURING PRINCIPLE

The ULM<sup>®</sup> ultrasonic level meters are compact measurement devices containing an ultrasonic transmitter and an electronic module. Using an transmitter, level meters transmit the series of ultrasonic pulses that spread towards the level surface. The transmitter recuperates reflected acoustic waves that are subsequently processed in the electronic module. Based on the period during which the individual pulses spread towards the level and back, this period is averaged by the electronics that performs temperature compensation and subsequently a conversion to an output current (voltage).

---

## RANGE OF APPLICATION

For continuous non-contact level measurement of liquids (water solutions, sewerage water, etc.), mash and paste materials (sediments, sticks, resins etc.) in closed or open vessels, sumps, reservoirs and open channels. In case the level of bulk-solid materials is measured, the measurement range is reduced.

All setting-up is done using two buttons positioned in the upper part of the sensor. The level meter is equipped with optical state indication (STATE) and with a setting-up process (MENU). The level meter can output current or voltage signals. They are manufactured in model versions for non-explosive areas (N) and explosive areas (Xi).

---

## FEATURES OF VARIANTS

- ULM-53\_-02\_-** *measuring range from 0.25 m to 2 m*, plastic PVDF transmitter and plastic body (PP+HDPE), process connection with thread G 1".
- ULM-53\_-06\_-** *measuring range from 0.25 m to 6 m*, plastic PVDF transmitter and plastic body (PP+HDPE), process connection with thread G 1 ½".
- ULM-53\_-10\_-** *measuring range from 0.5 m to 10 m*, plastic PVDF transmitter and plastic body (PP+HDPE), aluminium alloy ("Xi" version) or HDPE ("N" version) flange.
- ULM-53\_-20\_-** *measuring range from 0.5 m to 20 m*, with plastic PVDF transmitter and plastic body (PP+HDPE), aluminium alloy flange.

# DIMENSIONAL DRAWINGS

ULM-53\_-02-\_

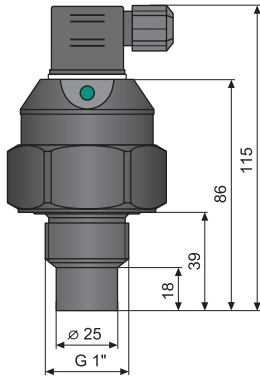

ULM-53\_-06-\_

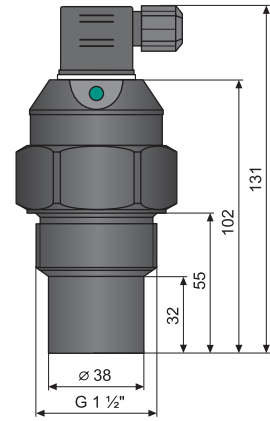

ULM-53N-10-\_

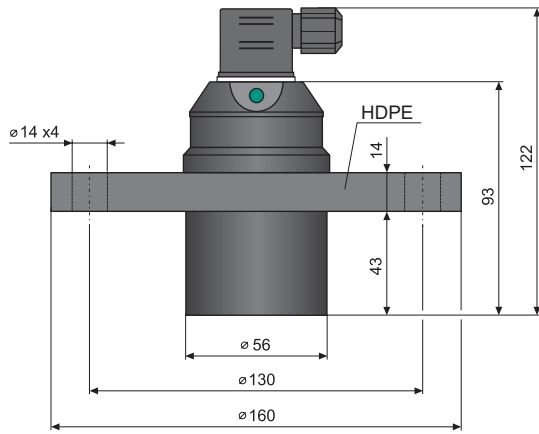

ULM-53Xi-10-I

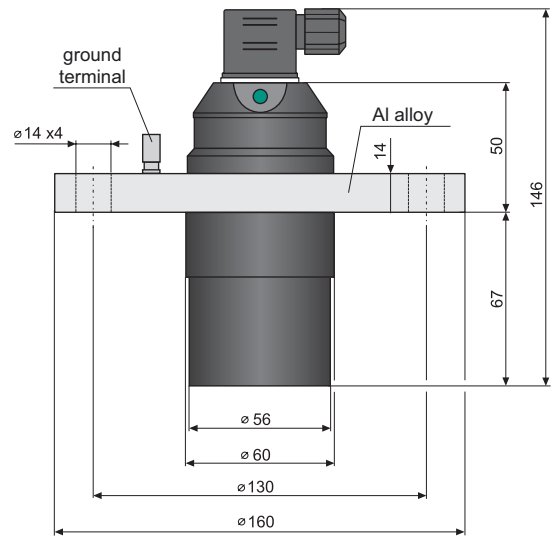

ULM-53\_-20-\_

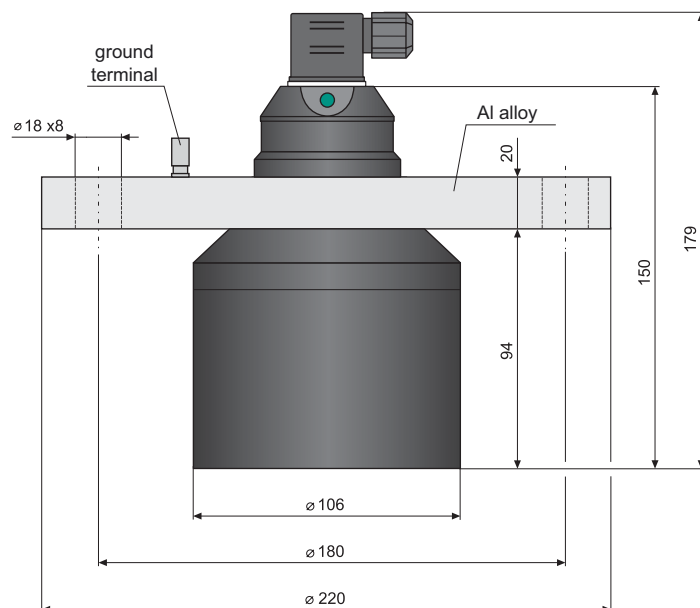

# INSTALLATION INSTRUCTIONS

- Install the level meter in a **vertical position** into the upper lid of the tank (vessel) or reservoir using a lug, a fastening nut or a flange in such a way that the ULM axis is perpendicular to the level of the measured liquid (Fig. 1).
- Minimum **dimension parameters** when installing into a lid or a ceiling of a tank are listed in Fig. 3.
- When installing in an **open channel** (reservoir, drain and the like), install the level meter onto a console to the expected maximum level as close as possible.
- In compliance with the measurement principle, no signals **reflected** in the area directly below the level meter (the so-called dead zone) can be evaluated. **The dead zone** (Fig. 2) determines the minimum distance possible between the level meter and the highest surface level. Medium minimum distance parameters are listed in chapter on "Technical specifications".
- It is necessary to install the level meter in such a way that the bin level does not **interfere** with the dead zone when filled up to the maximum. If measured level interferes with the dead zone, the level meter will not work properly.

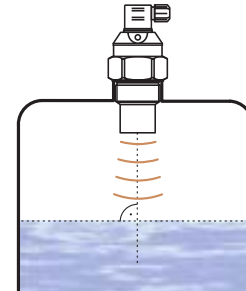

Fig. 1: Recommended installation in the tank

ULM-53-02 ; 10	$d > 1/12 c$ (min. 200 mm)
ULM-53-06	$d > 1/8 c$ (min. 200 mm)
ULM-53-20	$d > 1/10 c$ (min. 200 mm)

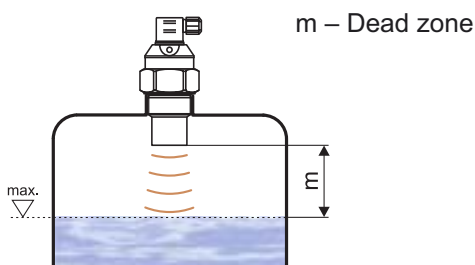

Fig. 2: Level meter dead zone

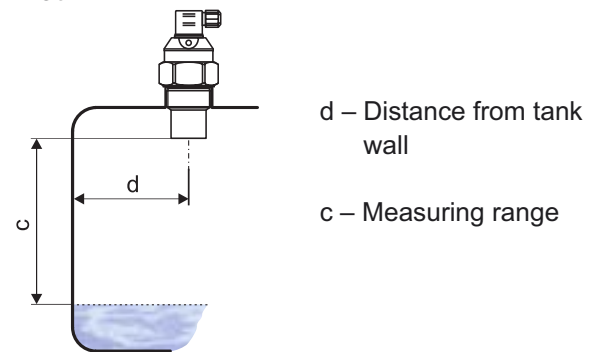

Fig. 3: Installation distance from the tank wall

- In case the maximum surface level in the tank interferes with the dead zone, the level meter has to be mounted into a higher **installation neck**. Subsequently, the tank can be filled nearly up to the maximum volume. The neck's inner surface has to be even and smooth (without edges and welded joints), the inner edge should be rounded in the position point where the ultrasonic waves leave the pipe. Choose the largest possible neck's diameter, but keep the neck's height as low as possible. Recommended dimensions of the neck are listed in Fig. 4.

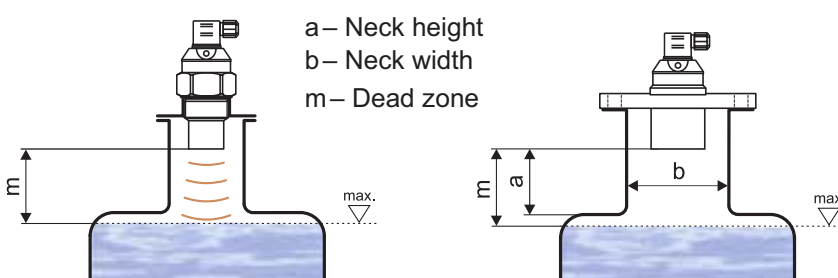

Fig. 4: Possible installation of the installation neck

ULM-53-02 ; 06	$a < 3b$ $b > 100 \text{ mm}$
ULM-53-10	$a < 1,5b$ $b > 100 \text{ mm}$
ULM-53-20	$a < 1,5b$ $b > 150 \text{ mm}$

- **Foam** on the level absorbs the acoustic wave reflection which might cause malfunction of the level meter. For mounting find the location where the foaming is as low as possible (Fig. 5).
- Emitted acoustic signal must not be affected by **near objects** (ladders, mixers, propellers, etc.), stream of filling, air flow, etc. (Fig. 6).

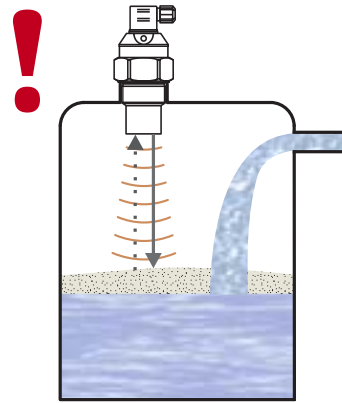

Fig. 5: Thick foam on the surface

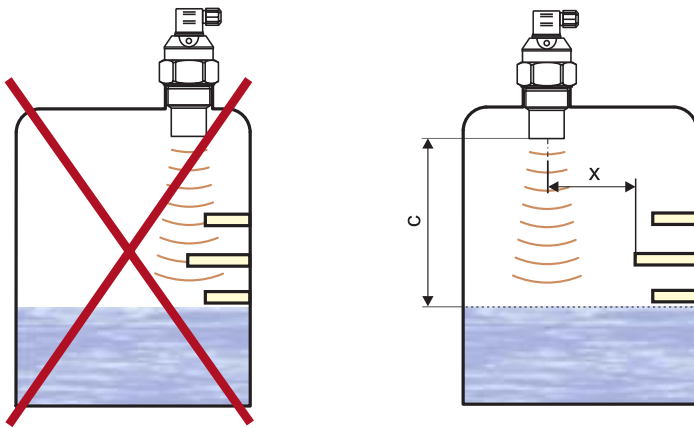

Fig. 6: Minimum distance of the level meter to nearby objects in the tank

ULM-53-02; 10	$x > 1/12 c$ (min. 200 mm)
ULM-53-06	$x > 1/8 c$ (min. 200 mm)
ULM-53-20	$x > 1/10 c$ (min. 200 mm)

x – distance to the edge of the longest object

c – measurement range of the level gauge

- Do not install the level meter in or above the **filling point**. (Fig. 7).

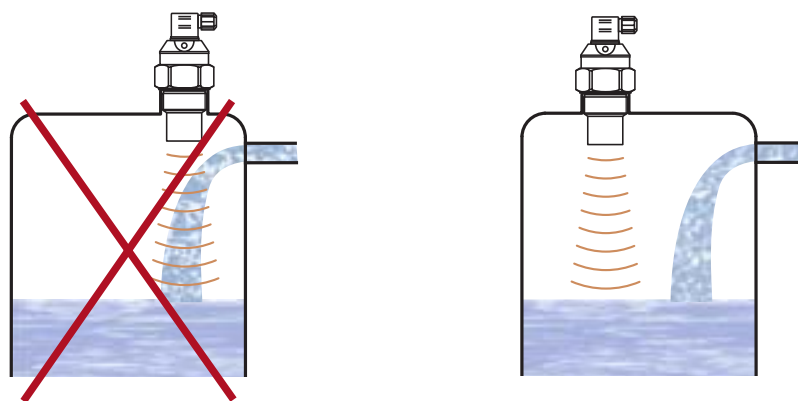

Fig. 7: Level meter installation outside the influence of filling circulation

- In case the level of **bulk-solid materials** is measured, the measurement range is reduced. We recommend to consult the use with the manufacturer.

- The level meter must not be installed in places with direct **solar radiation** and must be protected against weather conditions.
- In case the installation at places with direct solar radiation is inevitable, it is necessary to mount a **shielding cover** above the level meter (Fig. 8).
- If possible, insert the cable from above and let a draining loop in order to avoid intrusion of humidity (Fig. 9).
- The cable bushing as well as the connector have to be **tightened sufficiently** to prevent penetration of moisture.
- To lower the minimum distance to the medium measured, a **reflection board** made from solid, even and smooth material can be installed together with the level gauge (Fig. 10). Subsequently, the tank can be filled nearly up to the maximum volume. The solution is suitable for open tanks and reservoirs.
- Scattering or attenuation of the ultrasonic signal can result if the surface level has been **moderately stirred** or **rippled** as a consequence a stirrer's operation, inflow of liquid and the like. Consequently, measuring range or unreliable level meter's functioning might follow (Fig. 11).
- False surface reflections of the ultrasonic signal might result as a consequence of rotating mixer's blades that ripple the surface level and thus cause unreliable level meter's functioning (Fig. 12).
- The level meter should not be installed at places where ultrasonic signal **false reflections** caused by stirrer blades might occur (Fig. 13).

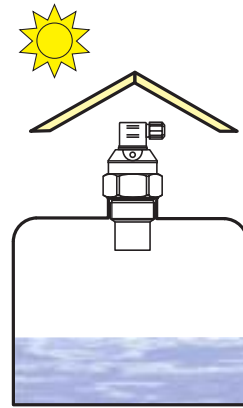

Fig. 8: Direct solar radiation shielding cover

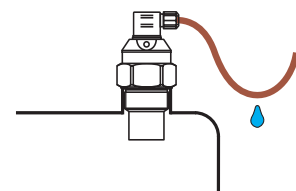

Fig. 9: Prevention to avoid intrusion of humidity

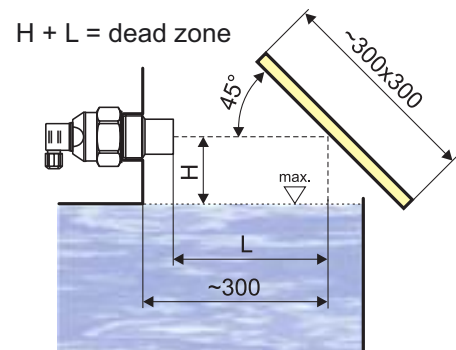

Fig. 10: Reflection board

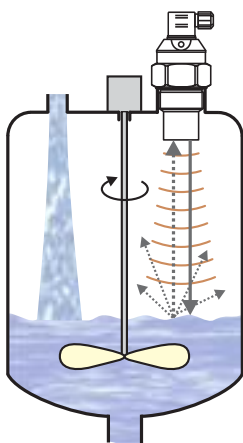

Fig. 11: Moderately stirred surface

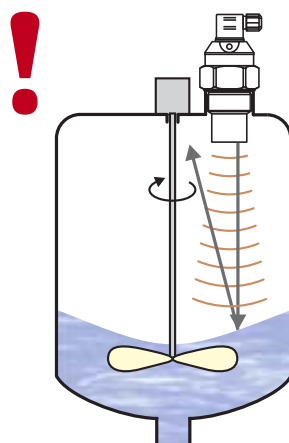

Fig. 12: Intensely stirred surface

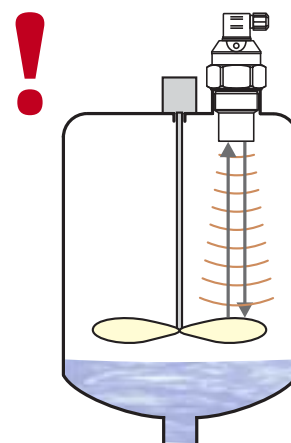

Fig. 13: False reflection caused by mixer blade



## ELECTRICAL CONNECTION

The ultrasonic level meter is designed to be connected to supply unit or to controller through two or three-wire cable with outer diameter  $6 \div 8$  mm (recommended cross section of cores  $0.5 \text{ mm}^2$  to  $0.75 \text{ mm}^2$ ) by means of connector which is included in delivery. Connection diagram and inner view of the connector as shown in Fig. 14 and 15.

Make the electric connection in **voltage-free state**.

Note: In case of strong electromagnetic interferences (EMI), parallel cable ducting with power lines, or when cable length exceeds 30m we recommended to use **shielded cable**.

### WARNING:

With regard to possible occurrence of **electrostatic charge** on non-conductive parts of the level meter, metallic flanges of the ULM-53Xi-10 and 20 (for explosive areas) level meters must be grounded with **ground terminal!**

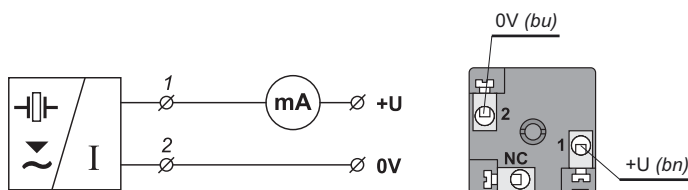

Fig. 14: Level meter connection diagram ("I" version) and the inside of the connector socket

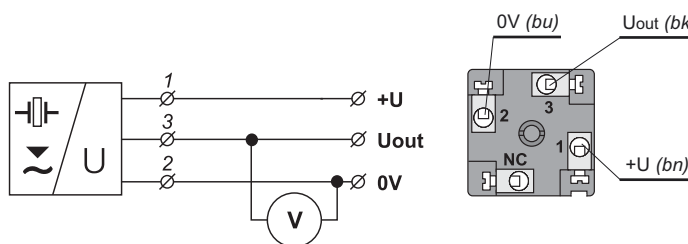

Fig. 15: Level meter connection diagram ("U" version) and the inside of the connector socket

**comments:** bk – black    bn – brown  
bu – blue    NC – not connected

## SET-UP ELEMENTS

### button "DOWN"

- set-up mode access
- direct set-up to value 4 mA (0V)
- decreasing of values by predefined pitch

### button "UP"

- set-up mode access
- direct set-up to value 20 mA (10V)
- increasing of values by predefined pitch

### LED indicator "STATE"

- signalling of measuring mode

### LED indicator "MENU"

- signalling of set-up mode access



Fig. 16: Full view of ultrasonic level meter

## STATUS AND FAILURE SIGNALIZATION

LED indicators	color	function
"STATE"	green	<p><b>Slow flashing</b> (1–2 sec., depends on the measuring interval) – reception of reflected signal (echo) from the measured level. Correct function.</p> <p><b>Fast blinks</b> – the measured value is in "dead zone" of the level meter, or the ultrasonic transmitter is polluted.</p> <p><b>Dark</b> – the measured value is in "dead zone" of the level meter, or the ultrasonic transmitter is polluted. Incorrect installation or malfunction.</p>
"MENU"	yellow	<p><b>Slow blinks</b> – signalization setting limit 4 mA (0V).</p> <p><b>Fast blinks</b> – signalization setting limit 20 mA (10V).</p>

## OPERATIONAL MODES

The level meters can either work in the "basic" mode that measures the level height (Fig. 17), or in the "inverse mode" that measures distances (Fig. 18).

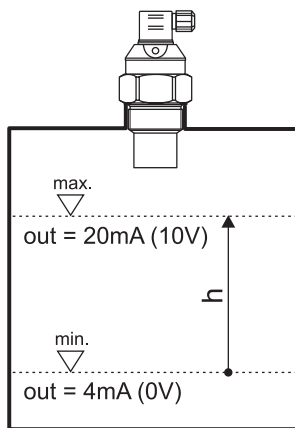

Fig. 17: Basic mode  
(measurement of level height)

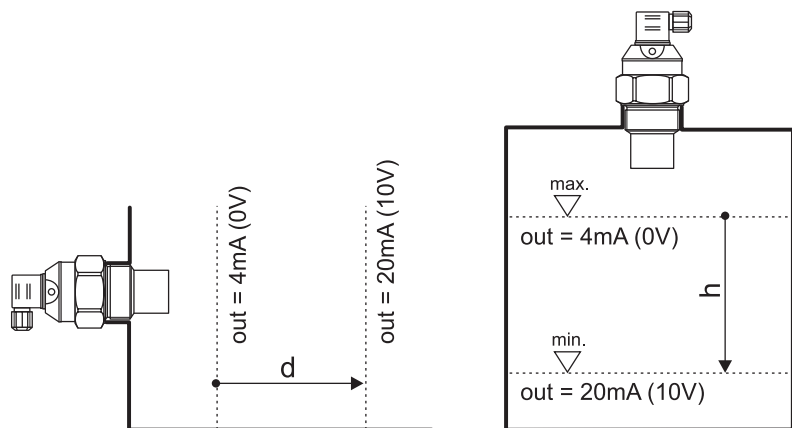

Fig. 18: Inverse mode  
(distance measurement)

## SETTING UP

After the level meter has been installed, set it up using the "DOWN" and "UP" buttons (see fig. 16). The LED indicator "MENU" indicates the on-going set-up procedure of the level meter. You can set up the "basic mode", which measures the level height (Fig. 17) and set up the "inverse mode" to measure distances (Fig. 18).

BASIC MODE :

### Low margin (4 mA or 0V) setting up

1. The tank fills up to the level required
2. Press the "DOWN" button for at least 2 seconds to activate the set-up mode (the LED indicator "MENU" blinks slowly). Keep the "DOWN" button pressed for another 3 seconds to directly set the value to 4 mA (0V). In this case, item 3 can be omitted.

3. Press the "DOWN" and "UP" buttons to accurately set-up an arbitrary value stepwise (hold the relevant button to increase the adjustment step gradually).
4. Press both buttons simultaneously for at least 1 second to confirm the values set.
5. Further adjustment cannot be performed sooner than 2 seconds after both of the buttons have been released.

#### **High margin (20 mA or 10 V) setting up**

1. The tank fills up to the level required
2. Press the "UP" button for at least 2 seconds to activate the setting-up mode (the LED indicator "MENU" blinks fast). Keep the "UP" button pressed for another 3 seconds to directly set the value to 20 mA (10 V). In this case, item 3 can be omitted.
3. Press the "DOWN" and "UP" buttons to accurately set-up an arbitrary value stepwise (hold the relevant button to increase the adjustment step gradually).
4. Press both buttons simultaneously for at least 1 second to confirm the values set.
5. Further adjustment cannot be performed sooner than 2 seconds after both of the buttons have been released.

INVERSE MODE:

#### **Low margin (20 mA or 10 V) setting up**

1. The tank fills up to the level required
2. Press the "UP" button for at least 2 seconds to activate the setting-up mode (the LED indicator "MENU" blinks fast). Keep the "UP" button pressed for another 3 seconds to directly set the value to 20 mA (10 V).
3. Press the "DOWN" and "UP" buttons to accurately set-up an arbitrary value stepwise (hold the relevant button to increase the adjustment step gradually).
4. Press both buttons simultaneously for at least 1 second to confirm the values set.
5. Further adjustment cannot be performed sooner than 2 seconds after both of the buttons have been released.

#### **High margin (4 mA or 0 V) setting up**

1. The tank fills up to the level required
2. Press the "DOWN" button for at least 2 seconds to activate the setting-up mode (the LED indicator "MENU" blinks slowly). Keep the "DOWN" button pressed for another 3 seconds to directly set the value to 4 mA (0 V).
3. Press the "DOWN" and "UP" buttons to accurately set-up an arbitrary value stepwise (hold the relevant button to increase the adjustment step gradually).
4. Press both buttons simultaneously for at least 1 second to confirm the values set.
5. Further adjustment cannot be performed sooner than 2 seconds after both of the buttons have been released.

*Note 1: In case the level appears in the dead zone (the LED indicator "STATE" blinks fast), the setting-up mode terminates instantly and is inaccessible as long as the level stays within the dead zone.*

*Note 2: In case no button is pressed during the "setting-up mode" for as long as 20 seconds, the level meter returns to the measuring mode. Newly adjusted values will not be saved.*

## ORDER CODE

ULM-53 □ - □ □ - □

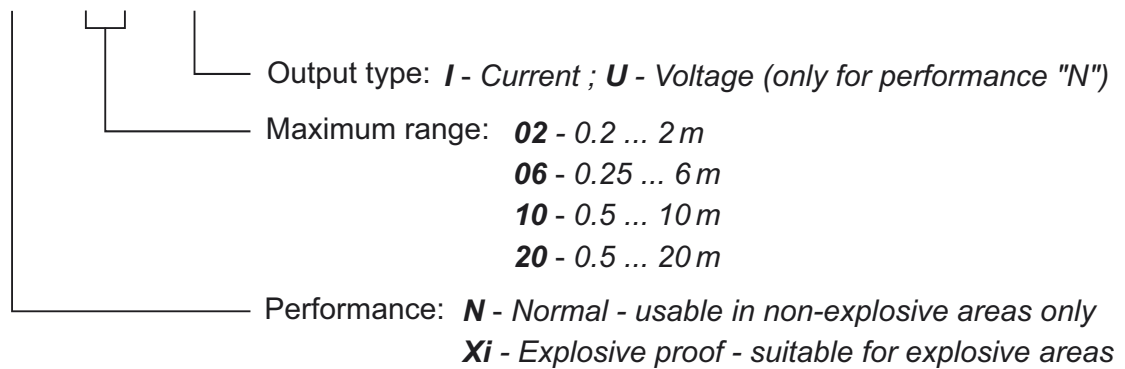

---

## ACCESSORIES

### *standard – included in the price*

- 1x Seal (only for ULM-53\_02, 06)
- 1x Connector socket with the IP67 protection class

### *optional – for extra charge*

- Stainless fixing nut UM-G1" (for ULM-53\_02\_06)
- Stainless fixing nut UM-G1 ½" (for ULM-53\_06\_06)

---

## SAFETY, PROTECTION, COMPATIBILITY AND EXPLOSION PROOF

The level meter ULM-53 is equipped with protection against reverse polarity and output current overload.

Protection against dangerous contact is secured by low safety voltage that complies with EN 33 2000-4-41.

Electromagnetic compatibility according to EN 55022/B, EN 61326/Z1 and EN 61000-4-2 to 6.

Explosion proof of ULM-53Xi type complies with the following standards: EN 60079-0 : 2007; EN 60079-11 : 2007 ; EN 60079-26 : 2007 and examined by FTZÚ-AO 210 Ostrava - Radvanice certificate No.: FTZÚ 09 ATEX 0119X.

---

## USE, MANIPULATION AND MAINTENANCE

The level meter does not require any personnel for its operation. Follow-up displaying device is used to inform the technological entity operating personnel on the measured substance level height during the operation.

Maintenance of this equipment consists in verification of integrity of the level meter and of the supply cable. Depending on the character of the substance measured, we recommend to verify at least once per year the clarity of the ultrasound transducer emitting field and to clean it, respectively. In case any visible defects are discovered, the manufacturer or reseller of this equipment must be contacted immediately.

It is forbidden to perform any modifications or interventions into the ULM-53 level meter without manufacturer's approval. Potential repairs must be carried out by the manufacturer or by a manufacturer authorized service organization only.

Installation, commissioning, operation and maintenance of the ULM-53 level meter has to be carried out in accordance with this instruction manual; the provisions of regulations in force regarding the installation of electrical equipment have to be adhered to.

## MARKING OF LABELS

Level meters label data **ULM-53N-02-I** and **ULM-53N-06-I**:

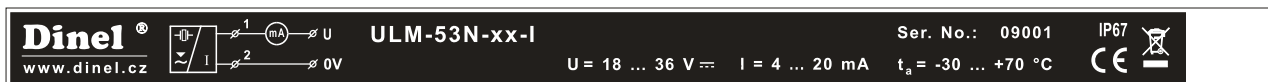

- Symbol of producer: Dinel logo®
- Internet address: www.dinel.cz
- Connection scheme and labelling of wires: U<sub>i</sub> ; 0V
- Level meter type: ULM-53N-02-I, ULM-53N-06-I
- Serial number: Ser. No.: xxxxx - (from the left: production year, serial production number)
- Supply voltage: U<sub>i</sub> = 18 ... 36 V ~
- Output current range: I<sub>o</sub> = 4 ... 20 mA
- Ambient temperature range: t<sub>a</sub> = -30 ... +70 °C
- Protection class: IP67
- Compliance mark: CE
- Electro-waste take-back system mark:

Level meters label data **ULM-53N-10-I** and **ULM-53N-20-I**:



- Symbol of producer: Dinel logo®
- Internet address: www.dinel.cz
- Connection scheme and labelling of wires: U<sub>i</sub> ; 0V
- Level meter type: ULM-53N-10-I, ULM-53N-20-I
- Serial number: Ser. No.: xxxxx - (from the left: production year, serial production number)
- Supply voltage: U<sub>i</sub> = 18 ... 36 V ~
- Output current range: I<sub>o</sub> = 4 ... 20 mA
- Ambient temperature range: t<sub>a</sub> = -30 ... +60 °C
- Protection class: IP67
- Compliance mark: CE
- Electro-waste take-back system mark:



Level meters label data **ULM-53Xi-02-I** a **ULM-53Xi-06-I**:

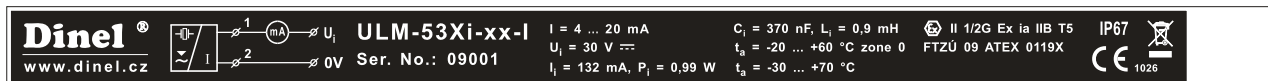

- Symbol of producer: Dinel logo®
- Internet address: www.dinel.cz
- Connection scheme and labelling of wires:  $U_i$  ; 0V
- Level meter type: ULM-53Xi-02-I, ULM-53Xi-06-I
- Serial number: Ser. No.: xxxxx - (from the left: production year, serial production number)
- Output current range:  $I_o = 4 \dots 20$  mA
- Limit operating parameters:  $U_i = 30$  V,  $I_i = 132$  mA;  $P_i = 0,99$  W;  $C_i = 370$  nF;  $L_i = 0,9$  mH
- Ambient temperature range for the zone 0:  $t_a = -20 \dots +60$  °C
- Ambient temperature range:  $t_a = -30 \dots +70$  °C
- Label of non-explosive device:
- Performance: II 1/2G Ex ia IIB T5
- Number of certificate of intrinsically safety: FTZÚ 09 ATEX 0119X
- Protection class: IP67
- Compliance mark:
- Number of authorized person examining control of system quality: 1026
- Electro-waste take-back system mark:

Level meters label data **ULM-53Xi-10-I**

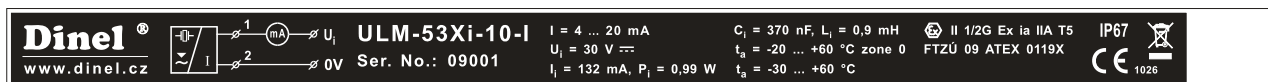

- Symbol of producer: Dinel logo®
- Internet address: www.dinel.cz
- Connection scheme and labelling of wire:  $U_i$  ; 0V
- Level meter type: ULM-53Xi-10-I
- Serial number: Ser. No.: xxxxx - (from the left: production year, serial production number)
- Output current range:  $I_o = 4 \dots 20$  mA
- Limit operating parameters:  $U_i = 30$  V,  $I_i = 132$  mA;  $P_i = 0,99$  W;  $C_i = 370$  nF;  $L_i = 0,9$  mH
- Ambient temperature range for the zone 0:  $t_a = -20 \dots +60$  °C
- Ambient temperature range:  $t_a = -30 \dots +60$  °C
- Label of non-explosive device:
- Performance: II 1/2G Ex ia IIA T5
- Number of certificate of intrinsically safety: FTZÚ 09 ATEX 0119X
- Protection class: IP67
- Compliance mark:
- Number of authorized person examining control of system quality: 1026
- Electro-waste take-back system mark:

Note: Real label size is 175x11mm.

## Level meters label data ULM-53Xi-20-I

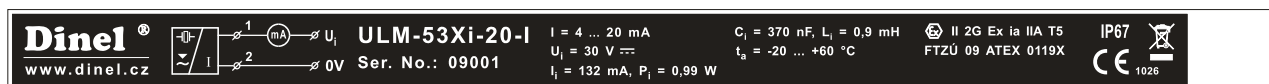

- Symbol of producer: Dinel logo®
- Internet address: [www.dinel.cz](http://www.dinel.cz)
- Connection scheme and labelling of wire:  $U_i$  ; 0V
- Level meter type: ULM-53Xi-20-I
- Serial number: Ser. No.: xxxxx - (from the left: production year, serial production number)
- Output current range:  $I_o = 4 \dots 20 \text{ mA}$
- Limit operating parameters:  $U_i = 30 \text{ V}$ ;  $I_i = 132 \text{ mA}$ ;  $P_i = 0,99 \text{ W}$ ;  $C_i = 370 \text{ nF}$ ;  $L_i = 0,9 \text{ mH}$
- Ambient temperature range for the zone 0:  $t_a = -20 \dots +60 \text{ }^\circ\text{C}$
- Ambient temperature range:  $t_a = -30 \dots +60 \text{ }^\circ\text{C}$
- Label of non-explosive device:  $\text{Ex}$
- Performance: II 2G Ex ia IIA T5
- Number of certificate of intrinsically safety: FTZÚ 09 ATEX 0119X
- Protection class: IP67
- Compliance mark: CE
- Number of authorized person examining control of system quality: 1026
- Electro-waste take-back system mark:  $\text{X}$



## TECHNICAL SPECIFICATIONS

Measuring range <sup>1)</sup>	ULM-53_-02-_	0.25 ... 2 m
	ULM-53_-06-_	0.25 ... 6 m
	ULM-53_-10-_	0.5 ... 10 m
	ULM-53_-20-_	0.5 ... 20 m
Supply voltage	ULM-53N-__-__	18 ... 36 V DC
	ULM-53Xi-__-I	18 ... 30 V DC
Current output ULM-53_-__-I Voltage output ULM-53N-__-U		4 ... 20 mA (limit values 3.9 ... 20.5 mA) 0 ... 10 V (limit values 0 ... 10.2 V)
Resolution		< 1 mm
Accuracy (within the total range)	ULM-53_-06-_; 10-_; 20-_	0.2%
	ULM-53_-02-_	0.3%
Temperature error		max. 0.04% / K
Beamwidth (-3 dB)	ULM-53_-02-_; 10-_	10°
	ULM-53_-06-_	14°
	ULM-53_-20-_	12°
Ambient temperature range	ULM-53_-02-_; 06-_	-30 ... +70°C
	ULM-53_-10-_; 20-_	-30 ... +60°C
Measuring period	ULM-53_-02-_	0.6 sec.
	ULM-53_-06-_	1.4 sec.
	ULM-53_-10-_	1.8 sec.
	ULM-53_-20-_	5.0 sec.
Averaging (can be modified according to agreement)		8 measuring
Short time temperature stress resistance		+90°C / 1 hour
Max. operation overpressure (on transmission surface)		0.1 MPa
Limit operating parameters <sup>2)</sup> (for the Xi version only)		U <sub>i</sub> =30V DC; I <sub>i</sub> =132mA; P <sub>i</sub> =0.99W; C <sub>i</sub> =370nF; L <sub>i</sub> =0.9mH
Failure indication	echo failure – basic mode	3.75 mA (0 V)
	echo failure – inverse mode	22 mA (10.5 V)
	level in dead zone – basic mode	22 mA (10.5 V)
	level in dead zone – inverse mode	3.75 mA (0 V)
Protection class		IP67
Recommended cable		PVC 2 x 0.75 mm <sup>2</sup> (3 x 0.5 mm <sup>2</sup> )
Current output load resistance (at U = 24 V DC)		R <sub>max</sub> = 270 Ω
Voltage output load resistance		R > 1 kΩ
Delay between supply power rise time and first measurement	ULM-53_-02-_; 06-_; 10-_	3 sec.
	ULM-53_-20-_	5 sec.
Delay between power supply rise time and full emission output	ULM-53_-02-_; 06-_; 10-_	30 sec.
	ULM-53_-20-_	45 sec.
Weight	ULM-53_-02-_	0.20 kg
	ULM-53_-06-_	0.25 kg
	ULM-53_-10-_	0.65 kg
	ULM-53_-20-_	2.80 kg

<sup>1)</sup> In case the level of bulk-solid materials is measured, the measurement range is reduced.

<sup>2)</sup> Allowed temperature range in the zone 0: -20°C ... +60°C; allowed pressure range in the zone 0: 80 ... 110 kPa.

**AREA CLASSIFICATION** (according to EN 60079-10 and EN 60079-14)

ULM-53N-__-__	Performance for non-explosive areas
ULM-53Xi-02-I ULM-53Xi-06-I	Explosive proof – suitable for explosive areas (combustible gases or vapours) ⊕ II 1/2G Ex ia IIB T5 with isolating repeater (IRU-420), the whole level meter – zone 1, front head part – zone 0
ULM-53Xi-10-I	Explosive proof – suitable for explosive areas (combustible gases or vapours) ⊕ II 1/2G Ex ia IIA T5 with isolating repeater (IRU-420), the whole level meter – zone 1, front head part – zone 0
ULM-53Xi-20-I	Explosive proof – suitable for explosive areas (combustible gases or vapours) ⊕ II 2G Ex ia IIA T5 with isolating repeater (IRU-420), the whole level meter – zone 1



# **Dinel**<sup>®</sup>

industrial electronics

**Dinel, s.r.o.**  
U Tescomy 249  
760 01 Zlín  
Czech Republic

Phone: +420 577 002 003  
Fax: +420 577 002 007

E-mail: [sale@dinel.cz](mailto:sale@dinel.cz)  
[www.dinel.cz](http://www.dinel.cz)

The latest version of this instruction manual can be found at [www.dinel.cz](http://www.dinel.cz)  
(version 02/2010)



QMS  
ISO 9001

