

871EC Series Electrodeless Conductivity Sensors and Accessories



Foxboro 871EC Electrodeless Conductivity Sensors, in conjunction with a variety of supporting sensor accessories, provide fouling-resistant measurements in all types of process liquids. Because of the electrodeless technique and innovative sensor design, years of continuous operation and meaningful indication of solution conductivity will be realized.

INTRODUCTION

The electrodeless conductivity sensors measure an induced current in a loop of solution. Two or three⁽¹⁾ toroidally wound coils are encapsulated in close proximity within the sensor which is immersed in the solution. An ac signal, applied to one toroidal coil, induces a current in the second coil, which is directly proportional to the conductance of the solution. This current is the input to a Foxboro 875EC Intelligent Analyzer, an 870ITEC Intelligent Transmitter, an 870EC Analog Transmitter, or an 873EC and 873AEC Electrochemical Analyzer, all used for electrodeless conductivity measurement.

HIGH SENSITIVITY

Through the use of innovative design technology⁽¹⁾, Invensys Foxboro has extended the range of electrodeless conductivity measurement capability. Whereas previous sensors were limited to ranges of 1000 $\mu\text{S}/\text{cm}$ minimum full scale, Foxboro large bore PEEK sensors can be ranged as low as 0 to 50 $\mu\text{S}/\text{cm}$, with sensitivities as low as approximately 8 $\mu\text{S}/\text{cm}$. This permits measurements in low conductivity applications such as boiler feedwater or steam condensate, where heretofore the electrodeless technique was not sufficiently sensitive.

(1) Refer to the back page of this document for a list of approved patents, and patents pending, relating to this product.

PEEK MATERIAL SOLVES APPLICATION PROBLEMS

PEEK (Polyetheretherketone) is a thermoplastic material with superb strength and chemical resistance properties over a wide range of process temperatures and pressures. PEEK sensors are available in both small and large bore configurations; each type is capable of measuring conductivity at temperatures up to 200°C (392°F).

WIDE APPLICATION FLEXIBILITY

The 871EC Electrodeless Conductivity Sensors are available in a number of configurations and materials suitable for a variety of conditions that may be present in highly corrosive process solutions. These process conditions may include fouling by oil, algae or suspended impurities, abrasive slurry erosion, or metallic corrosion in highly active chemical solutions (e.g., caustics, saline solutions, and acids). Refer to Table 1 for approximate conductivity values of many common solutions.

VERY RELIABLE DESIGN

Foxboro PEEK sensors utilize a proprietary sensor head sealing technique which obviates the need for physical seals such as O-rings or epoxies. This results in a sensor of extraordinary integrity and virtually impervious to leakage from process fluids.

EASY MAINTENANCE

All sensors incorporate short passages and sufficiently large bores to virtually eliminate the difficulties caused by the buildup of process material and electrode polarization that is experienced with direct contact electrodes. Because of the materials of construction and innovative design, sensor maintenance is typically negligible.

VERSATILE SENSOR MOUNTINGS

Modular sensor design offers a choice of several different mounting methods. In-line installations are achieved via threaded bushings, flanges, and ball valve assemblies. A process seal is achieved by the sensor O-ring sealing against the bushing or flange inside diameter. All sensors may also be submersed by using a standpipe and coupling. Refer to Sensor Mounting Arrangements section further in this document for typical sensor mountings.

INTEGRAL TEMPERATURE SENSING

Sensors have an integral temperature element (either a thermistor or an RTD) for the monitoring of process solution temperature. Encapsulating the thermistor or RTD (resistance temperature detector) ensures that it is located in intimate thermal contact with the process solution being monitored, thereby providing an accurate response.

OPERATING CONDITIONS

See Functional Specifications, Sensor Applications, and Accessories Sections that follow.

SYSTEM PERFORMANCE SPECIFICATIONS

Refer to the PSSs listed below for System Performance Specifications when the 871EC Sensors are used with the following transmitters or analyzers.

PSS Number	Description
PSS 6-3C3 A	870EC Electrochemical Transmitter
PSS 6-3N2 A	870ITEC Intelligent Electrochemical Transmitter
PSS 6-1C1 E	873EC Electrochemical Analyzer
PSS 6-1C1 F	873AEC Analog Electrochemical Analyzer
PSS 6-3N1 C	875EC Intelligent Electrochemical Analyzer

FUNCTIONAL SPECIFICATIONS

Sensor Span Limits, Materials, Temperature Limits, Pressure Limits, and Temperature Compensator

Sensor Body Code(a)	Full Scale Measurement	Wetted Parts	Temperature Limits	Pressure Limits	Temperature Compensator (Integral)
Standard Temperature PEEK – up to 120°C (250°F)					
-SP	1.0 mS/cm (1000 µS/cm) Minimum(b) and 2000 mS/cm Maximum	Glass-filled PEEK; EPDM, Viton™, Kalrez, or Chemraz O-rings, as specified	-5 and +120°C (20 and 250°F)	-0.1 and +1.75 MPa (-15 and +250 psi)	100 K Ω thermistor for use with 873EC, 873AEC, and 875EC Analyzers, or 870ITEC and 870EC Transmitters.
-RE	1.0 mS/cm (1000 µS/cm) Minimum(b) and 1000 mS/cm Maximum	Glass-filled PEEK; EPDM, Viton, Kalrez, or Chemraz O-rings, as specified		-0.1 and +2.41 MPa (-15 and +350 psi)	
-LB	0.05 mS/cm (50 µS/cm) Minimum(b) and 50 mS/cm Maximum	Glass-filled PEEK; EPDM, Viton, Kalrez, or Chemraz O-rings, as specified			
High Temperature PEEK – up to 200°C (390°F)					
-HP	1.0 mS/cm (1000 µS/cm) Minimum(b) and 2000 mS/cm Maximum	Glass-filled PEEK; EPDM, Viton, Kalrez, or Chemraz O-rings, as specified	-5 and +200°C (20 and 390°F)	-0.1 and +1.75 MPa (-15 and +250 psi)	100 Ω platinum RTD for use with 873EC, 873AEC, and 875EC Analyzers, and 870ITEC Transmitter. See Note (c) for 870EC Transmitters.
-BW	1.0 mS/cm (1000 µS/cm) Minimum(b) and 1000 mS/cm Maximum	Glass-filled PEEK; EPDM, Viton, Kalrez, or Chemraz O-rings, as specified		-0.1 and +2.41 MPa (-15 and +350 psi)	
-UT	0.05 mS/cm (50 µS/cm) Minimum(b) and 50 mS/cm Maximum	Glass-filled PEEK; EPDM, Viton, Kalrez, or Chemraz O-rings, as specified			

See next page for non-PEEK versions.

FUNCTIONAL SPECIFICATIONS (Cont.)

Sensor Span Limits, Materials, Temperature Limits, Pressure Limits, and Temperature Compensator (Cont.)

Sensor Body Code(a)	Full Scale Measurement	Wetted Parts	Temperature Limits	Pressure Limits	Temperature Compensator (Integral)
Non-PEEK Versions					
-PP	1.0 mS/cm (1000 μ S/cm) Minimum (b) and 2000 mS/cm Maximum	Virgin Polypropylene; EPDM, Viton, Kalrez, or Chemraz O-rings, as specified	1.4 MPa at 80°C (200 psi at 176°F) is linearly derated to 1.05 MPa at 120°C (150 psi at 250°F)		100 Ω platinum RTD for use with 873EC, 873AEC, and 875EC Analyzers, and 870ITEC Transmitter.
-PT	1.0 mS/cm (1000 μ S/cm) Minimum (b) and 2000 mS/cm Maximum	Virgin Polypropylene; EPDM, Viton, Kalrez, or Chemraz O-ring, as specified			100 k Ω thermistor for use with 873EC, 873AEC, and 875EC Analyzers, or 870ITEC and 870EC Transmitters.
-NL	1.0 mS/cm (1000 μ S/cm) Minimum(b) and 2000 mS/cm Maximum	Glass-filled Noryl™; EPDM O-rings	-5 and +65°C (20 and 150°F)	-0.1 and +1.4 MPa (-15 and +200 psi)	See Note (c) for 870EC Transmitters.
-TF		Fluorocarbon head; 316 ss or Carpenter™ 20 Cb(d) extension as specified; EPDM or Viton(e), Kalrez, or Chemraz O-rings, as specified	-5 and +105°C (20 and 225°F)		
-EV	0.2 mS/cm (200 μ S/cm) Minimum(b) and 2000 mS/cm Maximum	Epoxy head; 316 ss extension; EPDM O-rings		-0.1 and +0.7 MPa (-15 and +100 psi)	
-AB	2.0 mS/cm (2000 μ S/cm) Minimum and 500 mS/cm Maximum	Linatex (natural rubber); 316 ss extension; EPDM or Viton O-rings, as specified	-5 and +65°C (20 and 150°F)		
-PN	1.0 mS/cm (1000 μ S/cm) Minimum and 2000 mS/cm Maximum	Glass-filled Noryl; 316 ss extension; EPDM O-rings	-5 and +105°C (20 and 225°F)	-0.1 and +1.4 MPa (-15 and +200 psi)	
-PX	1.0 mS/cm (1000 μ S/cm) Minimum and 2000 mS/cm Maximum	Glass-filled Noryl; Glass filled Noryl extension; EPDM O-rings			

(a) In process fluids operating at electrical potentials above 30 V rms or 60 V dc, refer to Invensys Foxboro for applicable sensor.

(b) These minimum spans are for sensors used with 873EC, 873AEC, and 875EC Analyzers and 870ITEC Transmitters. For minimum spans for sensors used with 870EC Transmitters, refer to ranges given in PSS 6-3C3 A.

(c) If -HP, -PT, -BW, or -UT sensor is to be used with 870EC Transmitter, then no temperature compensation can be applied, so 870EC must have Model Code Suffix A for temperature compensation selection.

(d) For sulfuric acid (99.5 to 93%) and oleum ranges, use optional Carpenter 20 Cb mounting extension.

(e) For sulfuric acid (99.5 to 93%), oleum ranges, and petroleum applications, use optional Viton O-rings.

FUNCTIONAL SPECIFICATIONS (Cont.)

Table 1. Approximate Conductivity Values of Common Solutions

Standard Curves(b)	Typical Conductivity Values at Reference Temperature and at Various Percent Concentrations Values Listed in this Table are in mS/cm(a)													
	1%	5%	10%	15%	18%	20%	25%	35%	42%	93%	96%	99.50%	99.90%	99.99%
NaCl (25°C) 0 to 25%	20	80	140	188	212	225	248							
H ₃ PO ₄ (25°C) 0 to 35%	10	32	64	92	112	123	153	208						
HCl (25°C) 0 to 15%	112	430	700	820										
H ₂ SO ₄ (25°C) 0 to 25%	50	221	440	595	670	721	790							
H ₂ SO ₄ (50°C) 99.5 to 93%										230	205	63	46	42
H ₂ SO ₄ (30°C) 96 to 93%										158	130			
Oleum (65°C) 42 to 18%					76	74	64	34	15					
Oleum (65°C) 0 to 10%	39	67	79											
HNO ₃ (25°C) 0 to 10%	63	281	500											
NaOH (25°C) 0 to 15%	60	220	355	410										
NaOH (50°C) 0 to 15%	76	320	530	650										
NaOH (100°C) 0 to 20%	100	495	850	1110	1230	1310								
KOH (25°C) 0 to 6%	38.5	178												
KCl (20°C) 0 to 16%	15.7	71.9	143	208										
CH ₃ COOH (25°C) 0 to 8%	0.64	1.43												
HF (25°C) 0 to 30%	11.7	59	120.5	189.5	236	260	325							
HF (0°C) 90 to 99.9%											224	39.9	12.6	2.089
Na ₂ CO ₃ (85°C) Green Liquor	Typically some combination of sodium hydroxide, sodium carbonate, and sodium sulfite; 1000 mS/cm most commonly used for Full Scale Range.													
Na ₂ O (160°C) Black Liquor	Can be, for example, some combination of the following: sodium hydroxide and sodium carbonate, and could include sodium thiosulfate, sodium sulfide, and sodium sulfate; 1000 mS/cm typically used for Full Scale Range.													

(a) The conductivity values listed have been taken from data published by numerous sources and are to be considered estimations only.

Therefore, this table is provided for reference only, and precise conductivity values should be determined independently.

(b) The standard curves listed are resident in the following transmitter and analyzer memories:

- 870ITEC Intelligent Electrochemical Transmitter
- 875EC Intelligent Electrochemical Analyzer.

ELECTRICAL SAFETY SPECIFICATIONS

Testing Laboratory, Type of Protection, and Area Classification	Application Conditions	Electrical Safety Design Code
ATEX Certifications - 871EC Sensors with ATEX Certified Instruments		
ATEX Type ia, intrinsically safe for II 1 GD, EEx ia IIC, Zone 0.	Temperature Class T3-T6; T110°C - T260°C.	CS-E/AAA
ATEX Type n, energy limited for II 1 GD, EEx nL IIC, Zone 2.	Temperature Class T3-T6; T110°C - T260°C.	CS-E/ANN
CSA Certifications - 871EC Sensors with CSA Approved Instruments		
CSA ordinary locations.	Connect 871EC Sensor to approved instrument per installation instructions.	CS-E/CAA CS-E/CNN
CSA intrinsically safe, Class I, II, III, Division 1, Groups A, B, C, D, E, F, G.	Connect 871EC Sensor to approved instrument per installation instructions.	CS-E/CAA
CSA nonincendive, Class I, Division 2, Groups A, B, C, D; suitable for Class II, Div. 2, Groups E, F, G; and Class III, Div. 2.	Connect 871EC Sensor to approved instrument per installation instructions.	CS-F/CNN
CSA Certifications - 873EC and 873AEC Analyzers with 871EC Sensors		
CSA ordinary locations.	Connect to 873EC and 873AEC Analyzer per installation instructions.	873EC-...CGZ- 873EC-...CNZ-
CSA nonincendive, Class I, Division 2, Groups A, B, C, D; suitable for Class II, Div. 2, Groups F, G; and Class III, Div. 2.	Connect to 873EC and 873AEC Analyzer per installation instructions.	873EC-...CNZ-
CSA Certifications - 870EC Transmitter with 871EC Sensors		
CSA ordinary locations.	Connect to 870EC Transmitter per installation instructions.	CS-E/CBA CS-E/CNA
CSA intrinsically safe, Class I, II, III, Division 1, Groups A, B, C, D, E, F, G.	Connect to 870EC Transmitter per installation instructions.	CS-E/CBA
CSA nonincendive, Class I, Division 2, Groups A, B, C, D; suitable for Class II, Div. 2, Groups F, G; and Class III, Div. 2.	Connect to 870EC Transmitter per installation instructions.	CS-E/CNA
CSA Certifications - 870ITEC Transmitter with 871EC Sensors		
CSA ordinary locations.	Temperature Class T4, Ta = 85°C maximum ambient. Connect to 870ITEC Transmitter per installation instructions.	CS-E/CAA CS-E/CNZ
CSA intrinsically safe, Class I, II, III, Division 1, Groups A, B, C, D, E, F, G.	Temperature Class T4, Ta = 85°C maximum ambient. Connect to 870ITEC Transmitter per installation instructions.	CS-E/CAA
CSA nonincendive, Class I, Division 2, Groups A, B, C, D; suitable for Class II, Div. 2, Groups F, G; and Class III, Div. 2.	Temperature Class T4, Ta = 85°C maximum ambient. Connect to 870ITEC Transmitter per installation instructions.	CS-E/CNZ
CSA Certifications - 875EC Analyzer with 871EC Sensors		
CSA ordinary locations.	Temperature Class T4A, Ta = 85°C maximum ambient. Connect to 875EC Transmitter per installation instructions.	875EC-..C-
CSA nonincendive, Class I, Division 2, Groups A, B, C, D; suitable for Class II, Div. 2, Groups E, F, G; and Class III, Div. 2.	Temperature Class T4A, Ta = 85°C maximum ambient. Connect to 875EC Transmitter per installation instructions.	875EC-..C-

See next page for FM approvals.

Testing Laboratory, Type of Protection, and Area Classification	Application Conditions	Electrical Safety Design Code
FM Approvals - 871EC Sensors with FM Approved Instruments		
FM ordinary locations.	Connect 871EC Sensor to approved instrument per installation instructions.	CS-E/FAA CS-E/FNN
FM intrinsically safe, Class I, II, III, Division 1, Groups A, B, C, D, E, F, G.	Connect 871EC Sensor to approved instrument per installation instructions.	CS-E/FAA
FM nonincendive, Class I, Division 2, Groups A, B, C, D; suitable for Class II, Div. 2, Groups F, G; and Class III, Div. 2.	Connect 871EC Sensor to approved instrument per installation instructions.	CS-F/FNN
FM Approvals - 873EC Analyzer with 871EC Sensors		
FM ordinary locations.	Connect to 873EC Analyzer per installation instructions.	873EC-...FGZ-. 873EC-...FNZ-.
FM nonincendive, Class I, Division 2, Groups A, B, C, D; suitable for Class II, Div. 2, Groups F, G; and Class III, Div. 2.	Connect to 873EC Analyzer per installation instructions.	873EC-...FNZ-.
FM Approvals - 870EC Transmitter with 871EC Sensors		
FM ordinary locations.	Connect to 870EC Transmitter per installation instructions.	CS-E/FBA CS-E/FNA
FM intrinsically safe, Class I, II, III, Division 1, Groups A, B, C, D, E, F, G.	Connect to 870EC Transmitter per installation instructions.	CS-E/FBA
FM nonincendive, Class I, Division 2, Groups A, B, C, D; suitable for Class II, Div. 2, Groups F, G; and Class III, Div. 2.	Connect to 870EC Transmitter per installation instructions.	CS-E/FNA
FM Approvals - 870ITEC Transmitter with 871EC Sensors		
FM ordinary locations.	Temperature Class T4, Ta = 85°C maximum ambient. Connect to 870ITEC Transmitter per installation instructions.	CS-E/FAA CS-E/FNZ
FM intrinsically safe, Class I, II, III, Division 1, Groups A, B, C, D, E, F, G.	Temperature Class T4, Ta = 85°C maximum ambient. Connect to 870ITEC Transmitter per installation instructions.	CS-E/FAA
FM nonincendive, Class I, Division 2, Groups A, B, C, D; suitable for Class II, Div. 2, Groups F, G; and Class III, Div. 2.	Temperature Class T4, Ta = 85°C maximum ambient. Connect to 870ITEC Transmitter per installation instructions.	CS-E/FNZ
FM Approvals - 875EC Analyzer with 871EC Sensors		
FM ordinary locations.	Temperature Class T4A, Ta = 75°C maximum ambient. Connect to 875EC Transmitter per installation instructions.	875EC-..F-.
FM nonincendive, Class I, Division 2, Groups A, B, C, D; suitable for Class II, Div. 2, Groups F, G; and Class III, Div. 2.	Temperature Class T4A, Ta = 75°C maximum ambient. Connect to 875EC Transmitter per installation instructions.	875EC-..F-.

PHYSICAL SPECIFICATIONS
Cable (See Note below)

Integral, 6 m (20 ft) standard length, multi-screened (multi-shielded) cable with the following jacket material:

IRRADIATED POLYOLEFIN JACKET

Used with Sensors -SP, -PP, -PT, -RE, -NL, -TF, -EV, and -LB

ptfe JACKET

Used with Sensors -HP, -BW, and -UT

NOTE

Integral cables with optional lengths between 3 and 30 m (10 and 100 ft) are offered. See Model Code section.

Sensor Mounting

All sensors contain an O-ring and 3/4-14 NPT pipe thread (pipe thread is full 3/4 NPT) for sensor types -RE, -LB, -BW, -UT, -PN, and -PX; and 3/4-14 NPSM (truncated 3/4 NPT) for sensor types -SP, -HP, -PP, -PT, -NL, -TF, -EV, and -AB). See Accessories, Sensor Mounting Arrangements, and Dimensions-Nominal sections that follow.

INSERTION MOUNTING

Sensors are used with threaded bushings or flanges that form a process seal against sensor O-ring.

IN SITU MOUNTING

Mate to a user-supplied 3/4 in coupling and a length of DN 20 or 3/4 in pipe.

Ball Valve Mounting

Sensors are used with ball valve assemblies that contain connections for mating to the sensor, as shown in the Accessories and Dimensions-Nominal sections that follow.

NOTE

If insertion lengths greater than the standard lengths shown in the Dimensions-Nominal section are required, contact Invensys Foxboro.

In-Line Mounting

When mounted in-line, the sensors must be installed (centered) in either DN 80 or 3 in, or DN 150 or 6 in minimum pipe sizes to avoid pipe wall effects, as indicated below. Also see Note below.

- Use DN 80 or 3 in Minimum Pipe Size for Sensors -NL, -SP, -HP, -PP, -PT, and -TF;
- Use DN 150 or 6 in Minimum Pipe Size for Sensors -RE, -LB, -BW, -UT, and -EV.
- Use DN 230 or 9 in Minimum Pipe Size for Sensor -AB

NOTE

If insertion lengths greater than the standard lengths shown in the Dimensions-Nominal section are required, contact Invensys Foxboro.

Wetted Parts

See table in the previous Functional Specifications section for a listing of the wetted parts materials applicable to each sensor type.

NOTE

See Table 2 for Wetted Material Compatibility of Nonmetals with Process Solutions; and to Table 3 for Wetted Material Compatibility of Metals with Process Solutions.

Table 2. Wetted Material Compatibility of **Nonmetals** with Process Solutions

Standard Curves (Ref. Temp.) (a)	Temperature Compensation Range	Wetted Materials Compatibility of Nonmetals(b)									
		VPEEK	PCTFE	GFPEEK	PVDF	EPDM	Viton	Chemraz	GF Noryl	Boro-Silicate Glass	Virgin Polypropylene
NaCl (25°C) 0 to 25%	32 to 392°F	A 212°F	R 347°F	A 212°F	R 270°F	R 130°F	R 190°F	R 400°F	R 100°F	R 250°F	R 200°F
H ₃ PO ₄ (25°C) 0 to 35%	40 to 200°F	A 392°F	R 347°F	A 392°F	R 250°F	R 140°F	R 190°F	R 400°F	R 130°F	R 280°F	R 180°F
HCl (25°C) 0 to 15%	14 to 252°F	A 212°F	R @ the BP	A 212°F	R 280°F	R 100°F	R 350°F	R 400°F	R 150°F	R 230°F	R 190°F
H ₂ SO ₄ (50°C) 99.5 to 93% (@98%)	14 to 249°F	NO	NO DATA	NO	R 120°F	NO	R 350°F	R 400°F	R 170°F	R 380°F	R 100°F
H ₂ SO ₄ (50°C) 99.5 to 93% (@95%)	14 to 249°F	NO	R 300°F	NO	R 190°F	NO	R 330°F	R 400°F	R 70°F	R 380°F	NO
H ₂ SO ₄ (30°C) 96 to 93%(@90%)	50 to 194°F	NO	R 200°F	NO	R 180°F	NO	R 330°F	R 380°F	NO	R 380°F	R 150°F
H ₂ SO ₄ (25°C) 0 to 25%	14 to 249°F	A 212°F	R 77°F	A 212°F	R 220°F	R 140°F	R 350°F	R 400°F	R 80°F	R 390°F	R 170°F
H ₂ SO ₄ 100%	No Curve Support to 100%	NO	No Data	NO	NO	NO	R 160°F	R 400°F	NO	R 380°F	NO
H ₂ SO ₄ 80%	Custom	NO	Not Rated	NO	R 190°F	NO	R 340°F	R 380°F	R 80°F	R 380°F	R 140°F
H ₂ SO ₄ 70%	Custom	NO	Not Rated	NO	R 210°F	NO	R 340°F	R 380°F	R 80°F	R 380°F	R 160°F
H ₂ SO ₄ 60%	Custom	NO	Not Rated	NO	R 220°F	R 130°F	R 320°F	R 380°F	R 80°F	R 380°F	R 180°F
Oleum (65°C) 42 to 18%	89 to 249°F	NO	R @100% 77°F	NO	NO	NO	R 190°F	R 390°F	NO	R 380°F	NO
Oleum (65°C) 0 to 10%	89 to 249°F	NO	R @100% 77°F	NO	NO	NO	R 190°F	R 390°F	NO	R 380°F	NO
HNO ₃ (25°C) 0 to 10%	14 to 249°F	A 212°F	R 158°F	A 212°F	R 200°F	NO	R 400°F	R 400°F	R 130°F	R 380°F	R 170°F
NaOH (25°C) 0 to 15%	31 to 250°F	A 392°F	R >302°F	A 392°F	R 210°F	R 210°F	NO	R 400°F	R 130°F	NO	R 180°F
NaOH (50°C) 0 to 15%	32 to 212°F	A 392°F	R >302°F	A 392°F	R 210°F	R 210°F	NO	R 400°F	R 130°F	NO	R 180°F
NaOH (100°C) 0 to 20%	12 to 252°F	A 392°F	R >302°F	A 392°F	R 210°F	R 210°F	NO	R 400°F	NO	NO	R 180°F
KOH (25°C) 0 to 6%	50 to 104°F	A 77°F	R 176°F	A 77°F	R 210°F	R 250°F	NO	R 400°F	R 130°F	NO	R 150°F
KCl (20°C) 0 to 16%	32 to 77°F	A 212°F	No Data	A 212°F	R 280°F	R 300°F	R 400°F	R 400°F	R 130°F	R 240°F	R 180°F
CH ₃ COOH (25°C) 0 to 8%	40 to 250°F	A 212°F	R 347°F	A 212°F	R 300°F	R 140°F	R 190°F	R 400°F	R 130°F	R 380°F	R 190°F
HF (25°C) 0 to 30%	94 to 204°F	NO	R 77°F	NO	R 260°F	NO	R 210°F	R 300°F	NO	NO	R 150°F
HF (0°C) 90 to 99.9%	-4 to +406°F	NO	R 77°F	NO	R 200°F	NO	NO	R 400°F	NO	NO	R 160°F
Na ₂ CO ₃ (85°C) Green Liquor	94 to 204°F	A	No Data	A 212°F	R 280°F	R 300°F	R 190°F	R 400°F	NO	NO	R 160°F
Na ₂ O (160°C) Black Liquor	115 to 411°F	A	No Data	A	—	—	—	—	—	—	—
White/Brown Liq.	—	A	NO	A	—	—	—	—	—	—	—

(a) The standard curves of the solutions listed are resident in the 870ITEC Intelligent Transmitter and 875EC Intelligent Analyzer memories.

(b) The wetted materials compatibility for the solutions listed at a specified temperature are rated as follows:

A = No attack, little or no absorption; R = Recommended - Resistant to Solution; NO = Not Recommended

NOTES

1. Data relating to the compatibility of PCTFE material is based on information available from 3M.
2. The material compatibility data provided in the table above has been taken from data published by recognized experts, and can vary depending on the expert source. Therefore, the table is provided as a reference only, and the ultimate material selection is the responsibility of the user.
3. For material compatibility/solution concentrations other than those in the table above, contact Foxboro.

Table 3. Wetted Material Compatibility of **Metals** with Process Solutions

Standard Curves (Ref. Temp.)(a)	Temperature Compensation Range	Wetted Materials Compatibility of Metals(b)			
		316 ss	Carpenter 20	Hastelloy C	Titanium
NaCl (25°C) 0 to 25%	32 to 392°F	G 350°F	G 210°F	G 210°F	E 210°F
H ₃ PO ₄ (25°C) 0 to 35%	40 to 200°F	G 200°F	E 160°F G 210°F	E 150°F G 210°F	S 120°F
HCl (25°C) 0 to 15%	14 to 252°F	NO	NO	E 90 G 150°F	NO
H ₂ SO ₄ (50°C) 99.5 to 93% (@98%)	14 to 249°F	NO	E 100°F G 210°F	E 140°F G 240°F	NO
H ₂ SO ₄ (50°C) 99.5 to 93% (@95%)	14 to 249°F	G 200°F	E 110°F G 280°F	E 140°F G 280°F	NO
H ₂ SO ₄ (30°C) 96 to 93% (@90%)	50 to 194°F	NO	E 100°F G 210°F	E 140°F G 240°F	NO
H ₂ SO ₄ (25°C) 0 to 25%	14 to 249°F	NO	E 110°F G 210°F	E 130°F G 190°F	NO
H ₂ SO ₄ 100%	No Curve Support to 100%	G 200°F	E 100°F G 280°F	E 100°F G 190°F	NO
H ₂ SO ₄ 80%	Custom	NO	E 110°F S 150°F	E 240°F	NO
H ₂ SO ₄ 70%	Custom	NO	E 110°F S 150°F	G 190°F	NO
H ₂ SO ₄ 60%	Custom	NO	E 130°F S 160°F	E 130°F G 230°F	NO
Oleum (65°C) 42 to 18%	89 to 249°F	G 250°F	G 110°F	E 140°F	NO
Oleum (65°C) 0 to 10%	89 to 249°F	G 250°F	G 110°F	E 140°F	NO
HNO ₃ (25°C) 0 to 10%	14 to 249°F	E 210°F	E 210°F	E 210°F	E 240°F G 400°F
NaOH (25°C) 0 to 15%	31 to 250°F	E 150°F G 300°F	E 170°F G 300°F	G 210°F	E 210°F
NaOH (50°C) 0 to 15%	32 to 212°F	E 150°F G 300°F	E 170°F G 300°F	G 210°F	E 210°F
NaOH (100°C) 0 to 20%	12 to 252°F	E 170°F G 210°F	E 110°F G 300°F	G 210°F	E 210°F
KOH (25°C) 0 to 6%	50 to 104°F	G 350°F	G 210°F	G 210°F	E 200°F
KCl (20°C) 0 to 16%	32 to 77°F	G 350°F	G 210°F	G 210°F	E 210°F
CH ₃ COOH (25°C) 0 to 8%	40 to 250°F	E 400°F	E 220°F	E 300°F	E 260°F
HF (25°C) 0 to 30%	94 to 204°F	NO	G 190°F	G 210°F	NO
HF (0°C) 90 to 99.9%	-4 to +406°F	G 80°F	G 80°F	G 210°F	NO
Na ₂ CO ₃ (85°C) Green Liquor	94 to 204°F	G 350°F	E 200°F G >450°F	G 210°F	E 210°F
Na ₂ O (160°C) Black Liquor	115 to 411°F	-	-	-	-
White/Brown Liq.	-	-	-	-	-

(a) The standard curves of the solutions listed are resident in the 870ITEC Intelligent Transmitter and 875EC Intelligent Analyzer memories.

(b) The wetted materials compatibility for the solutions listed at a specified temperature are rated as follows:

E = Excellent, <2 mils per year; G = Good, <20 mils per year;
S = Satisfactory, <50 mils per year; NO = Not Recommended

NOTES



1. The material compatibility data provided in the table above has been taken from data published by recognized experts, and can vary depending on the expert source. Therefore, the table is provided as a reference only, and the ultimate material selection is the responsibility of the user.
2. For material compatibility/solution concentrations other than those in the table above, contact Foxboro.

SENSOR APPLICATIONS

NOTES

1. PEEK is a thermoplastic material with excellent strength and chemical resistance properties over a wide range of process temperatures and pressures. **Invensys Foxboro recommends using PEEK** preferentially for all applications that qualify.
2. PEEK material displays excellent chemical resistance to most aqueous solutions of acids, bases, and salts. It is also excellent for organic solvents such as toluene, ethyl acetate, acetone, gasoline, and carbon tetrachloride. It is not recommended for hydrofluoric acid applications, nor for sulfuric or nitric acid solutions above 40%, nor is it recommended for Oleum applications.

Sensor Applications – Standard Temperature PEEK – up to 120°C (250°F)



Sensor Code(a)	Application(a)	Sensor
-SP	This small bore sensor is suitable for the majority of all electrodeless conductivity applications. Its compact size enables it to be mounted in a multitude of methods, including insertion (flange, bushing), retractable, and in situ. Typical applications include salinity and brine measurements, steel pickling, scrubbing towers, ion exchange regeneration, plating baths, rinse water, caustic metal cleaning, and textile measurements in scouring, mercerizing and carbonizing baths.	
-RE	This large bore sensor is recommended as a substitute for 871EC-EV Series sensors, both for new and existing installations. Its large bore makes it particularly suitable for measurements with very high levels of fouling materials, such as limestone. Pulp and paper applications include brown stock washing (filtrate) and paper machine (white water). Additional applications include lye peeling of fruits and vegetables, oil well drilling (mudlogging), waste stream monitoring, and spill detection.	
-LB	This large bore sensor is used for low conductivity measurements where a sensitive range is required. It is often used in place of a conventional contacting conductivity measurement system to reduce maintenance, since fouling from oil, water treatment chemicals, particulates, etc. renders a contacting sensor inoperative. Typical applications involve water quality measurements such as boiler feedwater, steam condensate, rinse water, boiler blowdown, heat exchanger leakage, stream pollution, cooling towers and evaporators.	

(a) In process fluids operating at electrical potentials above 30 V rms or 60 V dc, contact Invensys Foxboro for applicable sensor.

NOTE



For High Temperature PEEK, and Non-PEEK versions, refer to the tables that follow.

Sensor Applications – High Temperature PEEK – up to 200°C (390°F)

Sensor Code(a)	Application(a)	Sensor
-HP	This small bore sensor is identical in physical size and appearance to the -SP sensor above, and may be applied to any of the -SP applications identified which have intermittent or continuously high temperatures. Additional high temperature applications for which this sensor is suited include alumina-to-caustic ratio in Bayer plants, boiler blowdown, and Clean-In-Place (CIP) measurements in food and related industries.	
-BW	This highly specialized, large bore sensor is intended for use in applications with a combination of both high temperatures and very high levels of fouling materials. Application areas overlap with those listed above for the type -HP sensor. Additional applications include pulp and paper measurements in green liquor (dissolving tank), first and second causticizer, and white and black liquor (digester).	
-UT	This large bore sensor is identical in physical size and appearance to the -LB sensor above. Applications for this sensor are generically the same as those identified for the -LB unit (e.g., low conductivity), except that the -UT sensor should be specified for situations where high temperatures may be present, either intermittently or continuously.	







(a) In process fluids operating at electrical potentials above 30 V rms or 60 V dc, contact Foxboro for applicable sensor.

Sensor Applications – Non-PEEK Versions

Sensor Code(a)	Application(a)	Sensor
-PP	This small bore sensor is suitable for many of the applications typically addressed by the -SP sensor; and also for those applications for which it is uniquely suited, e.g., HF, KCl, KOH, etc.	
-PT	This small bore sensor, similar to the -PP sensor, is suitable for many of the applications typically addressed by the -SP sensor; and also for those applications for which it is uniquely suited, e.g., HF, KCl, KOH, etc.	

Non-PEEK versions continued on next page

Sensor Applications – Non-PEEK Versions (Continued)

Sensor Code(a)	Application(a)	Sensor
-NL	This general purpose, small bore sensor may be used for most routine applications involving low (< 5%) concentrations of inorganic acids (hydrochloric, nitric, sulfuric, etc.), bases (caustic, calcium hydroxide, etc.), and salts (sodium chloride, calcium chloride, sodium sulfate, etc.). Not recommended where organic solvents are present. Not recommended in caustic applications above 50°C (122°F). When doubtful about the effect of high levels of chemicals, temperatures, or abrasion on the -NL sensor, specify a type -SP PEEK sensor as a preferred alternative.	
-TF	When used in oleum and concentrated (> 93%) sulfuric acid applications, select Carpenter 20 Cb (wetted material Code 2) and Viton O-ring (Option -V).	
-EV	This large bore sensor has been superseded by PEEK sensor type -RE. However, it should still be specified in beet sugar carbonation applications and in mining applications such as copper flotation, where highly abrasive slurries are present.	
-AB	This specialized large bore sensor is similar to sensor type -EV. It has a highly abrasion-resistant coating which is suitable for use in slurry and other abrasive applications.	
-PN	The -PN sensor is used for most general purpose and acidic applications where a 316 ss mounting extension is acceptable. It is not, however, recommended for use in caustic installations, and also not recommended for applications with concentrations greater than 5%.	
-PX	The -PX sensor is similar to the -PN sensor in that it is also used for most general purpose and acidic applications, however, where a glass-filled Noryl extension is acceptable. The -PX is also not recommended for use in caustic installations, and also not recommended for applications with concentrations greater than 5%.	

(a) In process fluids operating at electrical potentials above 30 V rms or 60 V dc, contact Invensys Foxboro for applicable sensor.

ACCESSORIES

Accessory Selection (For additional data, see accessories descriptions and specifications that follow)

Description	Select Foxboro Part
Bushing, AISI Type 316 ss 1 1/4 NPT 1 1/2 NPT 2 NPT R 1 1/2 Metric R 2 Metric	0051191 0051192 0051193 BS805JJ BS805JC
Bushing, Carpenter 20 Cb 1 1/4 NPT 1 1/2 NPT 2 NPT R 1 1/2 Metric R 2 Metric	0051176 0051177 0051178 BS805JK BS805JD
Bushing, Kynar 1 1/2 NPT 2 NPT R 1 1/2 Metric R 2 Metric	BS805JF BS805HZ BS805JH BS805JB
Bushing, Noryl 1 1/2 NPT 2 NPT R 1 1/2 Metric R 2 Metric	BS805JE BS805HY BS805JG BS805JA
Flange, 316 ss 2-in, MSS-SP-51 Class 150LW 2-in, ANSI Class 300 2 1/2-in, MSS-SP-51 Class 150LW 3-in, MSS-SP-51 Class 150LW 3-in, ANSI Class 300 4-in, MSS-SP-51 Class 150LW 4-in, MSS-SP-51 Class 150LW (Used with large bore PEEK sensors) 4-in, ANSI Class 300 4-in, ANSI Class 300 (Used with large bore PEEK sensors) DN 50, 10 bar DN 100, 10 bar	0051199 BS805PL 0051196 0051197 BS805PM 0051198 BS805XQ BS805PN BS805XS BS805JL BS805JM
Ball Valve Assemblies Purgeable Housing - 316 ss, 2-inch full port Nonpurgeable Housing - 316 ss, 2-inch full port Purgeable Housing - polypropylene, 2-inch full port Purgeable Housing - 316 ss, 3-inch full port	BS805JV BS805JU BS805HX BS806GE
Tri-Clamp™ Mounting Kits (For use with sensors -SP, -HP, -PP, and -PT only) 2-inch Adapter/Tri-Clamp and locknut 2 1/2-inch Adapter/Tri-Clamp and locknut 3-inch Adapter/Tri-Clamp and locknut 4-inch Adapter/Tri-Clamp and locknut	BS811QR BS811QS BS811QT BS811QU
Junction Box IEC IP65 and NEMA 4 specifications, watertight fittings	0051052
Extension Cable Assembly (With No. 6 spade lugs, both ends): Specify length up to 30 m (100 ft)	0060901
Extension Cable (Not terminated with spade lugs/not dressed): Specify length up to 300 m (1000 ft)	6000130

ACCESSORIES (Cont.)

Ball Valve Assemblies

Ball valve assemblies permit specified sensors to be removed from a process stream or tank under rated temperature and pressure without draining the system, or resorting to a bypass arrangement. The ball valve assembly comprises a ball valve, a housing, and an insertion shaft assembly, which allows the insertion of a sensor in a process stream. The housing, with or without purge ports, threads into the ball valve and accommodates the insertion shaft and sensor. For shaft insertion lengths longer than shown in the "DIMENSIONS-NOMINAL" section, contact Invensys Foxboro. Standard flexible conduit (user provided) can be used for cable protection. See table below, Figure 1, and Dimensions-Nominal section.

NOTE

When using an 871EC-HP Sensor for digester liquor measurements in the Pulp and Paper Industry, a ball valve installation is not recommended. Instead, use a metal bushing or an ANSI Class 300 Flange, or an 871FT Industrial Flow Through Sensor.

Table of Ball Valve Assembly Specifications and Part Numbers

Foxboro Part		Material of Processed Wetted Parts				Rated Pressure Note (c)		Maximum Temperature At Rated Pressure Note (c)		Used With 871EC Sensor Body Codes
Purgeable Housing	Non-Purgeable Housing	Process Line Connection and Housing	Ball Seat	Ball Valve	O-Ring Seal	MPa	psi	°C	°F	
BS805JV	BS805JU	316 ss Note (a)	ptfe	316 ss	EPDM	1.4	200	150	300	-TF, -SP -NL, -HP -PP, -PT
BS805HX	–	316 ss Note (a)	ptfe	poly-propylene	EPR	0.7 0.4 0.27	100 60 40	20 65 95	70 150 200	-TF, -SP -NL, -HP -PP, -PT
BS806GE	–	316 ss Note (b)	ptfe	316 ss	EPDM	2.1 0.7	300 100	177 200	350 390	-RE, -LB -BW, -UT

(a) Process line connection is 2-inch NPT (full port).

(b) Process line connection is 3-inch NPT (full port).

(c) Actual application rating may be reduced by Sensor Pressure-Temperature rating. See Functional Specifications section for sensor pressure-temperature ratings.

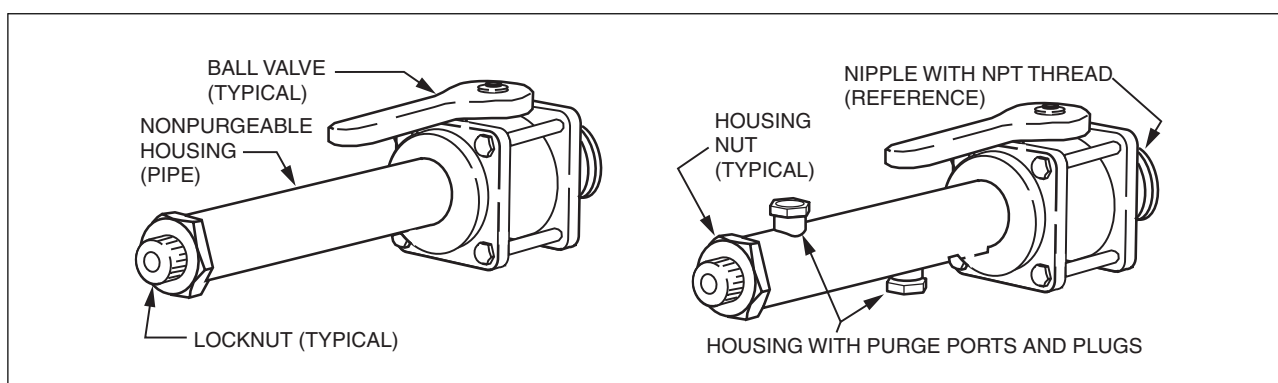

Figure 1. Typical Ball Valve Assemblies

ACCESSORIES (Cont.)

Flange Assemblies

Foxboro raised-face flange assemblies are used for permanent installations in pipelines and tanks. Flange assemblies are provided complete with a locknut and spacer(s) as shown in the table below and Figure 2.

Table of Flange Assembly Specifications and Part Numbers

Flange Description (a)	Flange Material	Flange Assembly Part No.(b)	Flange Assembly Parts(b)		Used With Sensor Body Codes
			Locknut Part No.	Spacer(s) Part No.(c)	
2-in ANSI Class 150(d)	316 ss	0051199	2800006 3/4 NPT	2705003(1) 2705004(2)	-TF, -NL, -SP, -HP, -PN, -PX, -PP, -PT
2-in ANSI Class 300	316 ss	BS805PL	2800006 (3/4 NPT)	2705004 (1)	-TF, -NL, -SP, -HP, -PN, -PX, -PP, -PT
2 1/2-in ANSI Class 150(d)	316 ss	0051196	2800006 3/4 NPT	2705003(1) 2705004(2)	-TF, -NL, -SP, -HP, -PN, -PX, -GL, -PP, -PT
3-in ANSI Class 150(d)	316 ss	0051197	2800006 3/4 NPT	2705003(2) 2705004(1)	-TF, -NL, -SP, -HP, -PN, -PX, -GL, -PP, -PT
3-in ANSI Class 300	316 ss	BS805PM	2800006 (3/4 NPT)	2705003 (1)	-TF, -NL, -SP, -HP, -PN, -PX, -GL, -PP, -PT
4-in ANSI Class 150(d)	316 ss	0051198	2800006 (3/4 NPT)	2705003 (2) 2705004 (1)	-EV, -TF, -NL, -SP, -HP, -PN, -PX, -GL, -AB, -PP, -PT
4-in ANSI Class 150(d)	316 ss	BS805XQ	2800006 (3/4 NPT)	BS805YX (1)	-RE, -LB, -BW, -UT
4-in ANSI Class 300	316 ss	BS805PN	2800006 (3/4 NPT)	2705003 (1)	-EV, -TF, -NL, -SP, -HP, -PN, -PX, -GL, -AB, -PP, -PT
4-in ANSI Class 300	316 ss	BS805XS	2800006 (3/4 NPT)	BS805YY (1)	-RE, -LB, -BW, -UT
DN 50 DIN 2501, 10 bar	316 ss	BS805JL	2800006 (3/4 NPT)	2705003 (2) 2705004 (1)	-TF, -NL, -SP, -HP, -PN, -PX, -PP, -PT
DN 100 DIN 2501, 10 bar	316 ss	BS805JM	2800006 (3/4 NPT)	2705003 (2) 2705004 (1)	-EV, -TF, -NL, -SP, -HP, -PN, -PX, -GL, -AB, -PP, -PT

- (a) Do not exceed the pressure-temperature ratings of the ANSI and DIN flanges listed.
- (b) The flange assembly part numbers listed include the flange itself, the locknut, and spacer(s).
- (c) The quantity in parentheses after the spacer part number represents how many spacers are provided.
- (d) MSS-SP-51 Class 150 LW.

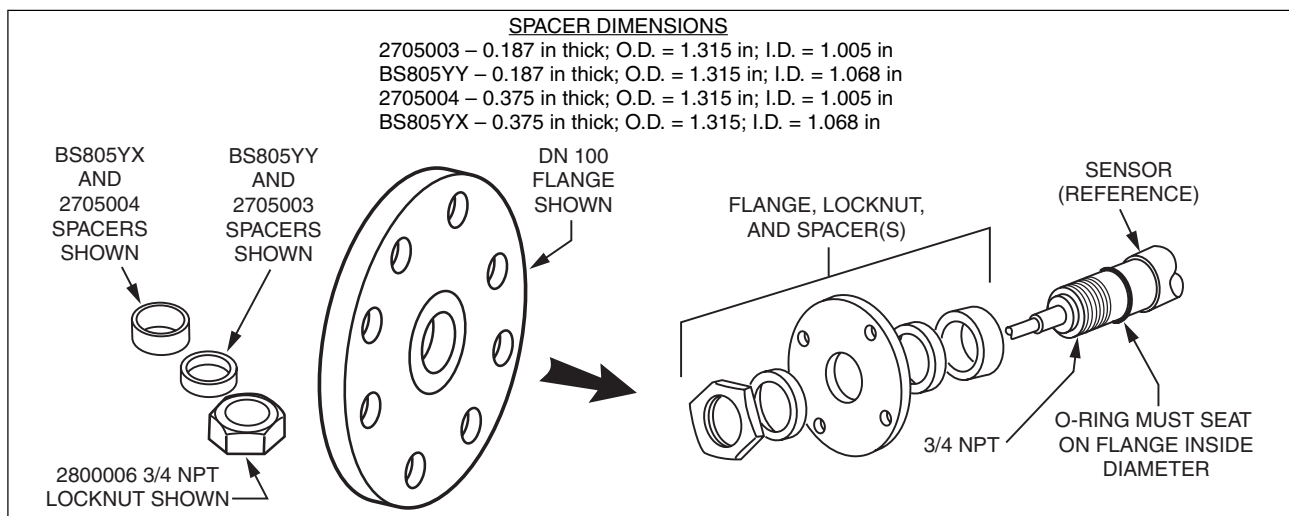

Figure 2. Typical Flange Assemblies

ACCESSORIES (Cont.)

Bushing Assemblies

Foxboro bushing assemblies are used for permanent installations in pipelines and tanks. Bushing assemblies are provided complete with a hexagonal head bushing and a locknut as shown in the table below and Figure 3.

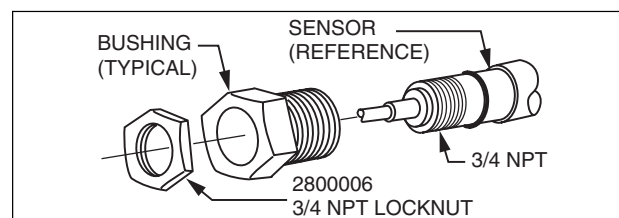

Figure 3. Typical Bushing Assembly

Table of Hexagonal-head Bushing Assembly Specifications and Part Numbers

Bushing Thread Size	Bushing Material	Bushing Assembly Part No. (a)	Locknut Part No. (b)	Rated Pressure		Maximum Temperature at Rated Pressure		Used With Sensor Body Codes (c)
				MPa	psi	°C	°F	
1 1/2 NPT R 1 1/2 metric 2 NPT R 2 metric	316 ss	0051192 BS805JJ 0051193 BS805JC	2800006 2800006 2800006 2800006	1.75	250	200	390	-TF, -NL, -SP, -HP, -PN, -PX, -GL, -PP, -PT
1 1/2 NPT R 1 1/2 metric 2 NPT R 2 metric	Carpenter 20 Cb	0051177 BS805JK 0051178 BS805JD	2800006 2800006 2800006 2800006	1.75	250	200	390	-TF, -NL, -SP, -HP, -PN, -PX, -GL, -PP, -PT
1 1/2 NPT R 1 1/2 metric 2 NPT R 2 metric	Kynar™ (PVDF)	BS805JF BS805JH BS805HZ BS805JB	2800006 2800006 2800006 2800006	1.0 0.4 0.2	150 60 30	25 80 120	75 180 250	-TF, -NL, -SP, -HP, -PN, -PX, -PP, -PT -GL
1 1/2 NPT R 1 1/2 metric 2 NPT R 2 metric	Noryl	BS805JE BS805JG BS805HY BS805JA	2800006 2800006 2800006 2800006	1.4 0.7 0.3	200 100 50	25 80 95	75 180 200	-TF, -NL, -SP, -HP, -PN, -PX, -PP, -PT -GL

(a) Bushing assembly part number shown includes both a bushing and locknut.

(b) Although the locknut is provided with the bushing assembly part number, its part number is also shown as additional information.

(c) Use the pressure-temperature limits of the bushing assembly, or the pressure-temperature limits of the sensor assembly, whichever is less. Refer to Functional Specifications section for sensor pressure-temperature ratings.

ACCESSORIES (Cont.)

Installation of Sensor Using a Tee

For in-line applications within a metal or plastic pipe, a tee installation is recommended. The minimum pipe (and tee) diameters must either be DN 80 or 3 in, or DN 150 or 6 in, depending on the 871EC Sensor used, as shown in Table 4. The sensor, whether horizontally or vertically installed, should be aligned as closely as possible with the centerline of the pipe to avoid pipe wall effects. See Table 4 and Figure 4.

NOTE

Larger pipe diameters than the minimums listed in Table 4 are preferred whenever possible. Refer to Table 1 for common solution conductivity values.

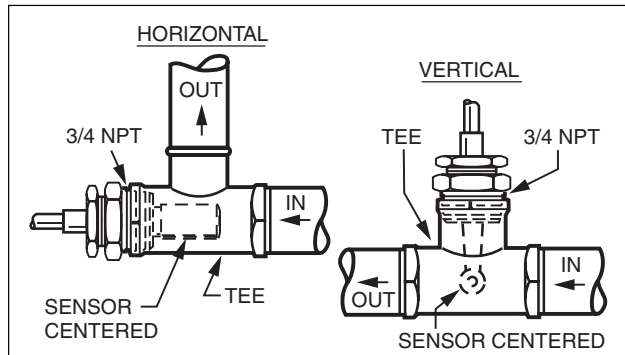

Figure 4. Tee Installations

Table 4. Minimum Pipe Diameter for In-Line Installations Using a Tee

Sensor Body Code	Minimum Pipe Dia.
-HP, -NL, -SP, -TF, -PP, -PT, PN, and PX	3 in (80 mm)
-BW, -EV, -LB, -RE, -UT	6 in (150 mm)
-AB	9 in (225 mm)

Tri-Clamp Mounting Kits

These kits are for use with the -SP, -HP, -PP, and -PT sensors. The Tri-Clamps are offered for users who require a sanitary or quick-disconnect mounting arrangement. The mating Tri-Clamp and connection, O-ring, and clamp are provided by the user. The kits are available in 2-, 2 1/2-, 3-, and 4-inch sizes. Refer to Table 5 and Figure 5.

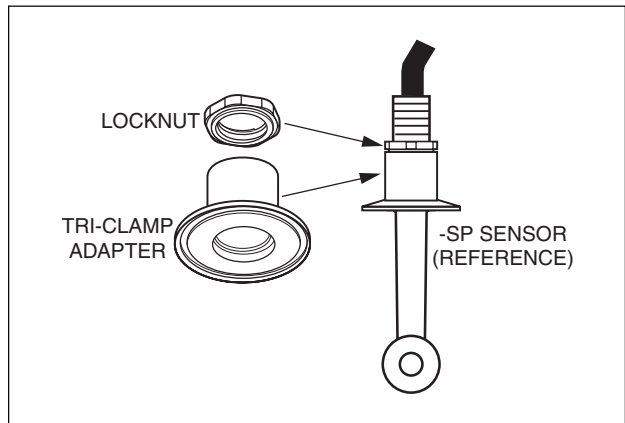

Figure 5. Tri-Clamp Mounting Kit

Table 5. Tri-Clamp Mounting Kits

Tri-Clamp Kit Size	Tri-Clamp Part No. (a)	Tri-Clamp Adapter Material	Locknut Part No. (b)	Tri-Clamp O.D.	O-Ring Groove Diameter (c)	Used with Sensor Codes
2-inch	BS811QL	316 ss or 316L ss	X0174CW (303 ss) (3/4 NPT)	2.510 in	2.216 in	-SP, -HP, -PP, and -PT
2 1/2-inch	BS811QM			3.047 in	2.781 in	
3-inch	BS811QN	3.579 in		3.281 in		
4-inch	BS811QP	4.685 in		4.331 in		

(a) The kit includes a Tri-Clamp adapter, locknut, grease, and a cotton swab.
 (b) Although the locknut is part of the kit, it is identified here for general information.
 (c) The O-ring groove diameter is to the centerline of the groove.

NOTES

1. Sensors -SP, -HP, -PP, and -PT can be ordered with a 2-in Tri-Clamp adapter and bushing by specifying -SP7, -HP7, -PP7, and -PT7 in the Model Code. The adapter and locknut are assembled to the sensor and are easily removed or replaced.
2. The -TF Sensor can also be ordered with a 2-in Tri-Clamp by specifying -TF7 (see Model Code). The -TF7, however, has an integral Tri-Clamp and the Tri-Clamp is not removable.
3. Use the pressure-temperature limits of the Tri-Clamp, or the pressure-temperature limits of the sensor assembly, whichever is less. Refer to Functional Specifications section for sensor pressure-temperature limits.

ACCESSORIES (Cont.)

Junction Box

The junction box, Foxboro Part 0051052 (Figure 6), provides interface for connecting the sensor assembly cable to the extension cable (see Extension Cable Assembly section below). A maximum 30 m (100 ft) separation of an 871EC Sensor and either an 870ITEC or an 870EC Transmitter, or an 873EC, 873AEC, or 875EC Intelligent Analyzer is recommended. The surface-mounted junction box is weatherproof and dusttight as defined by IEC IP65 and provides the watertight protection of NEMA Type 4.

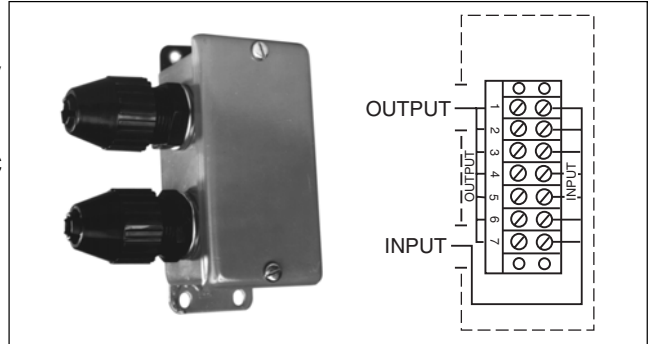

Figure 6. Junction Box and Terminal Connections (Foxboro Part 0051052)

Extension Cable Assembly

The extension cable assembly, Foxboro Part 0060901 (see Figure 7), is a PVC jacketed multi-conductor cable that provides intra-system connections up to 30 m (100 ft). Numbered leads, terminated in spade terminals, allow the extension cable assembly to be connected to the terminals in the junction box shown in Figure 6 above.

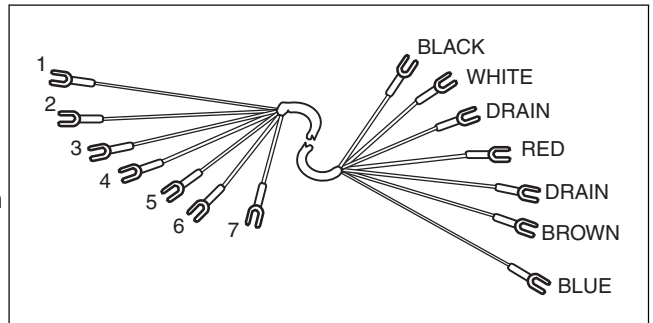

Figure 7. Extension Cable Assembly (Foxboro Part 0060901)

Extension Cable

The extension cable is a PVC jacketed multi-conductor cable without any spade terminals attached. It is available in lengths up to 300 m (1000 ft). Refer to Figure 8.

NOTE

Although the extension cable is available in lengths up to 300 m (1000 ft), a maximum separation of 30 m (100 ft) between the sensor and analyzer or the sensor and transmitter is recommended.

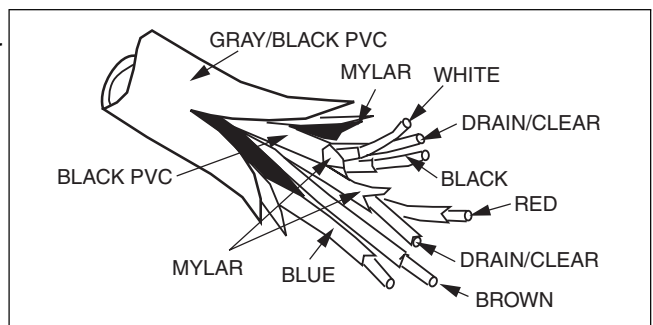

Figure 8. Extension Cable (Foxboro Part 6000130)

MODEL CODE

871EC Series Electrodeless Conductivity Sensors

Description	Model		
Electrodeless Conductivity Sensor	871EC		
Sensor Body Material, Temperature Limits, and Thermistor or RTD			
Sensor Body Material	Temperature Limits	Temp. Element	
PEEK, Small Bore	-5 and +120°C (20 and 250°F)	100 kΩ Thermistor	-SP
PEEK, Large Bore (Wide Range)	-5 and +120°C (20 and 250°F)	100 kΩ Thermistor	-RE
PEEK, Large Bore (High Sensitivity)	-5 and +120°C (20 and 250°F)	100 kΩ Thermistor	-LB
PEEK, Small Bore	-5 and +200°C (20 and 390°F)	100 Ω RTD	-HP
PEEK, Large Bore (Wide Range)	-5 and +200°C (20 and 390°F)	100 Ω RTD	-BW
PEEK, Large Bore (High Sensitivity)	-5 and +200°C (20 and 390°F)	100 Ω RTD	-UT
Noryl	-5 and +65°C (20 and 150°F)	100 kΩ Thermistor	-NL
Linatex (Natural Rubber)	-5 and +65°C (20 and 150°F)	100 kΩ Thermistor	-AB
Fluorocarbon	-5 and +105°C (20 and 225°F)	100 kΩ Thermistor	-TF
Epoxy	-5 and +105°C (20 and 225°F)	100 kΩ Thermistor	-EV
Virgin Polypropylene, Small Bore	-5 and +120°C (20 and 250°F)(a)	100 Ω RTD	-PP
Virgin Polypropylene, Small Bore	-5 and +120°C (20 and 250°F)(a)	100 kΩ Thermistor	-PT
Sensor Wetted Metallic and Mounting Parts			
None - Universal Mount			0
Used with Sensor Codes -SP, -HP, -LB, -UT, -RE, -BW, -NL, -PX, -PP, and -PT only			
Carpenter 20 Cb - Universal Mount			2
Used with Sensor Code -TF only			
316 ss - Universal Mount			3
Used with Sensor Codes -AB, -EV, -TF, and -PN only			
316 ss Sanitary Mounting Fitting, 2-inch Tri-Clamp (b)			7
Used with Sensor Codes -SP, -HP, -PP, -PT, and -TF only			
Optional Selections			
Cable Options			
Nonstandard Integral Cable; specify length from 1 to 30 m (3 to 100 ft) (c)			-3
Standard cable length is 6 m (20 ft)			
Not available with Option -5			
Pin Lug cable termination (d)			-4
Not available with Options -5, -6, and -7			
Nonstandard Integral Cable terminated in a connector plug (c)(e)(f)			-5
Specify length from 1 to 30 m (3 to 100 ft)			
Not available with Options -3, -4, -6, and -7			
Connector Integral to Sensor (b)(d)(f)			-6
Not available with Options -3, -4, -5, and -7			
Standard length, 6 m (20 ft), integral cable terminated in a connector plug (c)(e)(f)			-7
Not available with Options -3, -4, -5, and -6			
Integral Low Smoke Cable; specify length from 1 to 30 m (3 to 100 ft) (c)(d)(f)			-N

MODEL CODE (Continued)

871EC Series Electrodeless Conductivity Sensors (Continued)

<p>Optional Selections (Cont.) O-Ring Options (Available with Sensor Codes -SP, -HP, -LB, -UT, -RE, -BW, -TF, -PP, and -PT only) Chemraz O-rings Kalrez O-rings Viton O-rings Example: 871EC-SP0-34V</p>	<p>-C -K -V</p>
---	-------------------------

- (a) The -PP and -PT sensor temperatures are listed at 1.05 MPa (150 psi). The temperatures are linearly derated to 80°C (176°F) at a higher pressure of 1.4 MPa (200 psi). See Functional Specifications section.
- (b) TriClamp: Removable adapter for Sensor Codes -SP7, -HP7, -PP7, and -PT7; integral mounting fitting for Sensor Code -TF7. For 2-, 2 1/2-, 3-, and 4-in Tri-Clamp adapter kits, specify -SP, -HP, -PP, or -PT. Refer to Accessories section.
- (c) Include the patch cable and integral cable lengths when calculating the overall cable length for Options -5, -6, and -7.
- (d) All cables, not terminated with connectors or spade lugs, do have leads terminated with straight pin lugs and are compatible with all Foxboro Analyzers and Transmitters.
- (e) A patch cable is required with Options -5, -6, and -7. For these options, use:
- For Sensors -AB, -EV, -PN, -PX, -TF, -NL, -SP, -LB, -RE, -PP, and -PT, and low temperature applications up to 125°C (257°F)
 - Patch Cable Part No. BS811RL: Standard length of 6 m (20 ft)
 - Patch Cable Part No. BS811RM: Length per Sales Order up to 30 m (100 ft).
 - For Sensors -HP, -UT, -BW, and high temperature applications up to 200°C (390°F)
 - Patch Cable Part No. BS811RJ: Standard length of 6 m (20 ft)
 - Patch Cable Part No. BS811RK: Length per Sales Order up to 30 m (100 ft).
 - For applications requiring Low Smoke Cable and temperatures up to 90°C (194°F)
 - Patch Cable Part No. BS811RN: Standard length of 6 m (20 ft)
 - Patch Cable Part No. BS811RP: Length per Sales Order up to 30 m (100 ft).
- (f) Contact Invensys Foxboro.

DIMENSIONS—NOMINAL

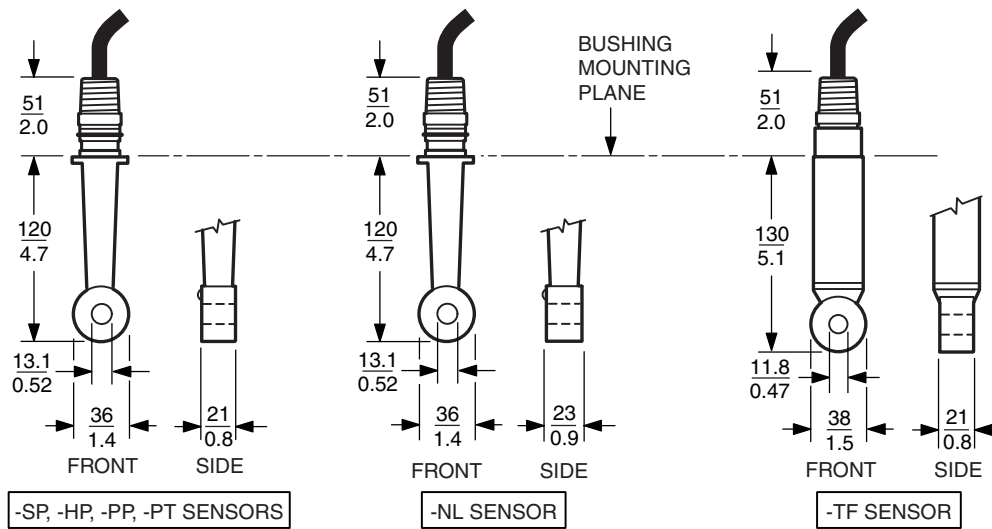
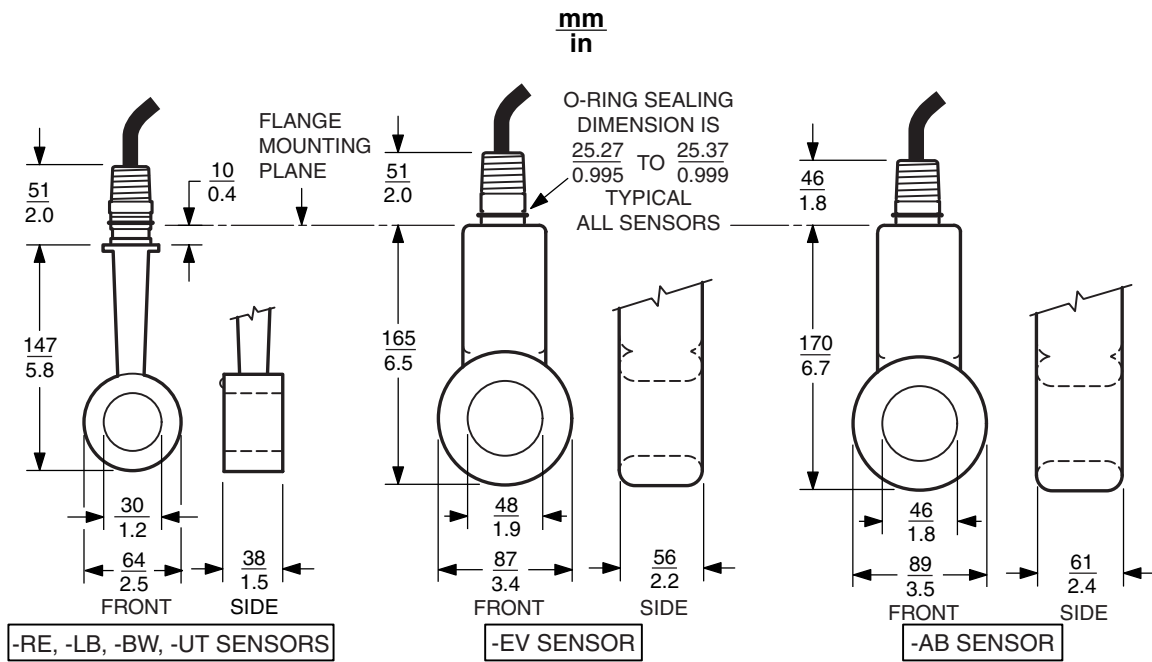

NOTES

1. The -HP, -SP, -PP, and -PT Sensors are also offered with 2 1/2-, 3-, and 4-inch Tri-Clamp adapter kits. Refer to Accessories section.
2. See next page for other 871EC Sensors and typical sensor mounting arrangements.

DIMENSIONS - NOMINAL (Cont.)

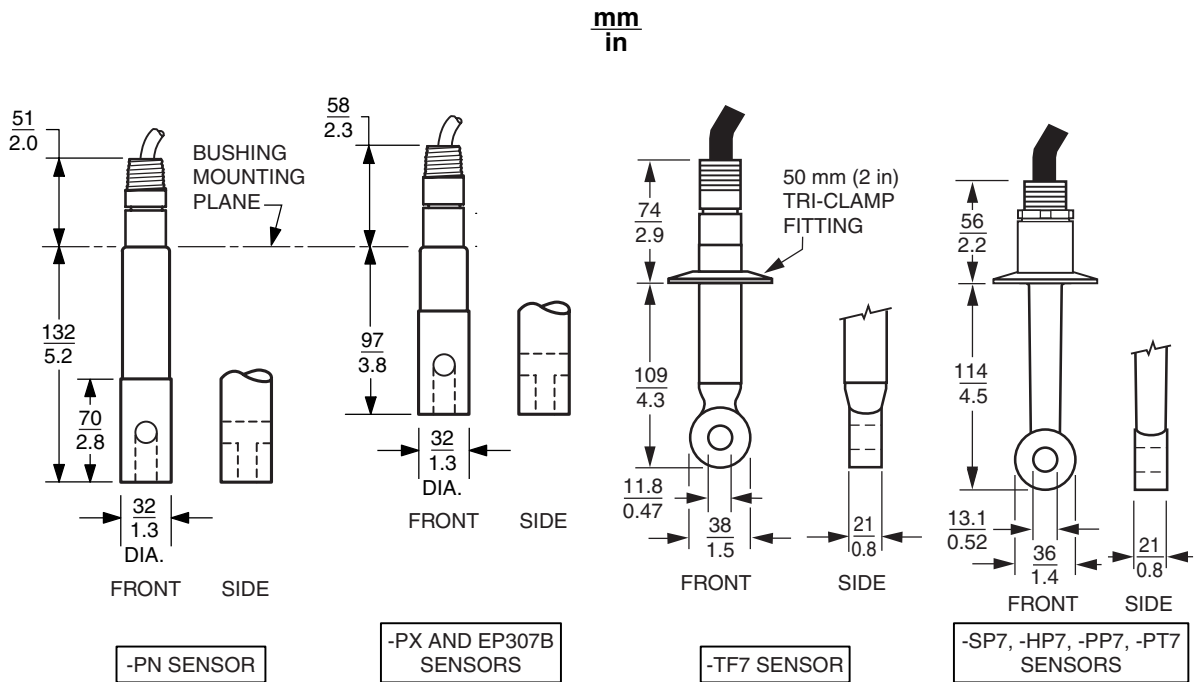

SENSOR MOUNTING ARRANGEMENTS

TYPICAL
IN SITU USE

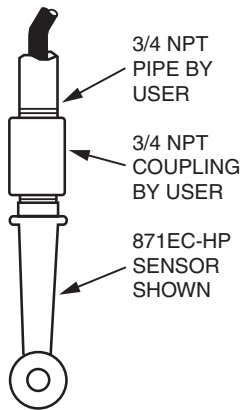

TYPICAL USE WITH BUSHING
AND CONDUIT CONNECTION

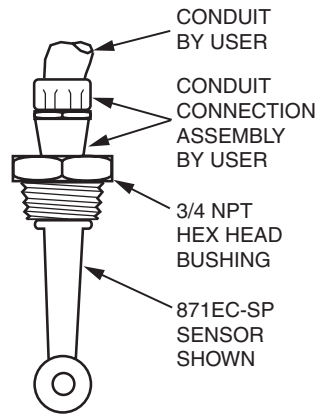

TYPICAL FLANGE
MOUNTING CONFIGURATION

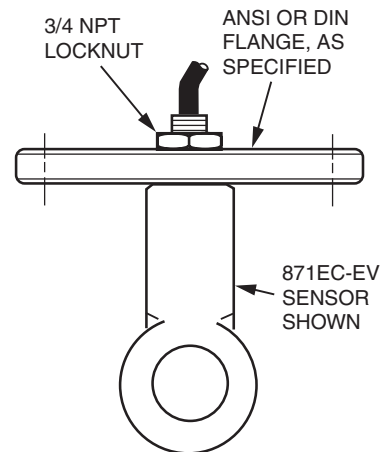

NOTE

Also refer to Dimensional Print DP 611-011 for 871EC Sensors and Sensor Mounting Arrangements.

DIMENSIONS—NOMINAL (Cont.)

**mm
in**

BALL VALVE ASSEMBLY FOR 871EC-NL, -HP, -SP, -TF, -PP, OR -PT SENSORS

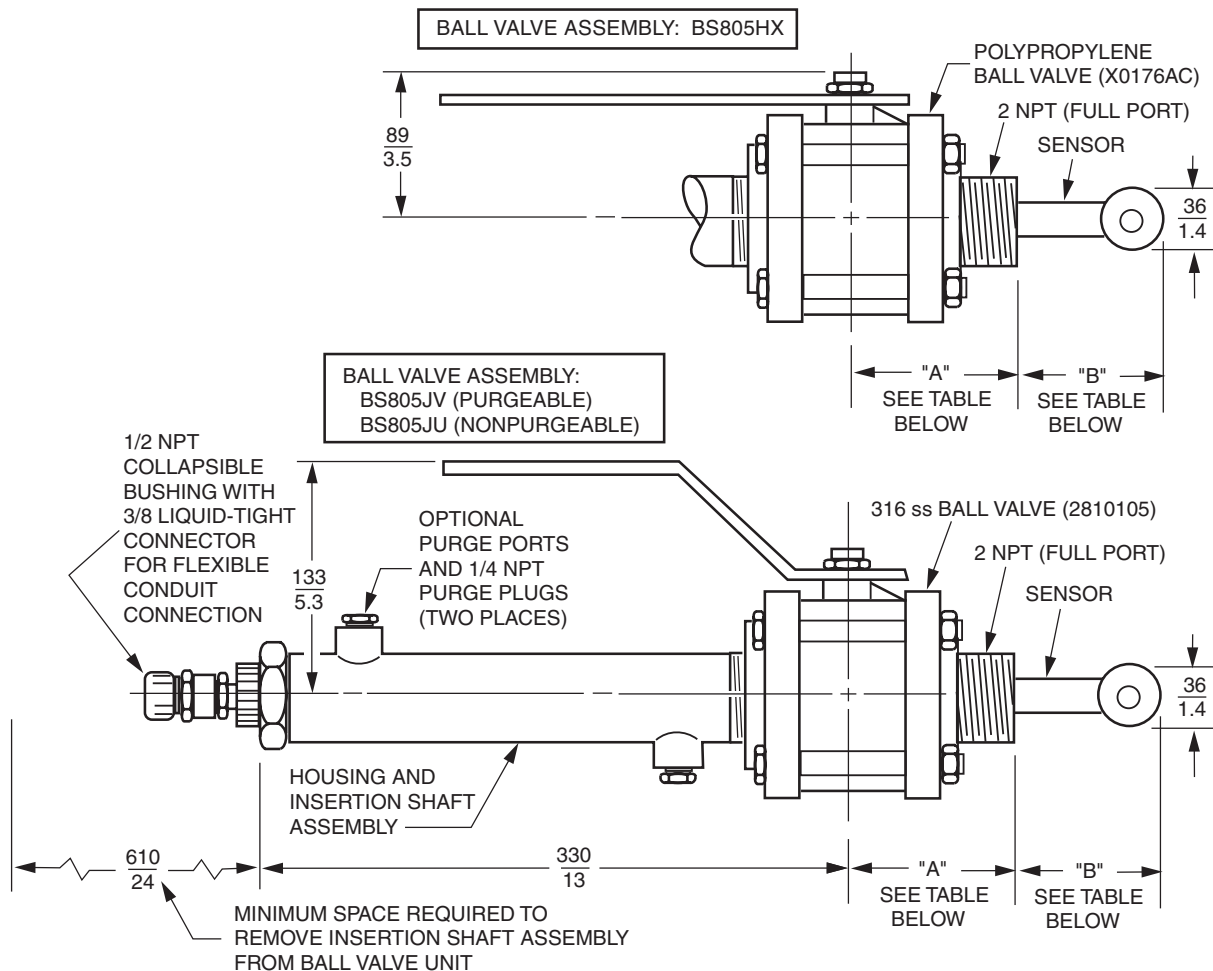

Ball Valve Assembly Part No.(a)	Housing Assembly 316 ss	Purge Plug Part No.	Valve Material			Insertion Shaft		Dimensions			
			Body	Seat	O-Ring Seal	Mat'l	O-Ring Seal	"A"	"B-1" (d)	"B-2" (d)	Insertion Shaft (c)
BS805JV	Purgeable	2700245 (316 ss)	316 ss	Reinforced ptfe(b)		316 ss	EPR (e)	$\frac{110}{4.3}$	$\frac{66}{2.5}$	$\frac{77}{3.0}$	$\frac{348.2}{13.7}$
BS805JU	Non-Purgeable	N/A	316 ss	Reinforced ptfe		316 ss	EPR (e)	$\frac{110}{4.3}$	$\frac{66}{2.5}$	$\frac{77}{3.0}$	$\frac{348.2}{13.7}$
BS805HX	Purgeable	2700245 (316 ss)	Polypropylene	ptfe	Viton	316 ss	EPR (e)	$\frac{107}{4.2}$	$\frac{69}{2.7}$	$\frac{79}{3.1}$	$\frac{348.2}{13.7}$

(a) Ball Valve Assembly includes ball valve, housing, and insertion shaft assemblies. See figures above for ball valve part numbers.

(b) ptfe = polytetrafluoroethylene (such as Teflon).

(c) Longer insertion lengths ("B") are available by using longer insertion shafts; contact Invensys Foxboro.

(d) Dimension "B-1" is for the 871EC-NL, -HP, -SP, -PP, and -PT Sensors.

Dimension "B-2" is for the 871EC-TF Sensor.

(e) Contact Invensys Foxboro.

DIMENSIONS—NOMINAL (Cont.)

**mm
in**

BALL VALVE ASSEMBLY FOR 871EC-RE, -LB, -BW, OR -UT SENSORS

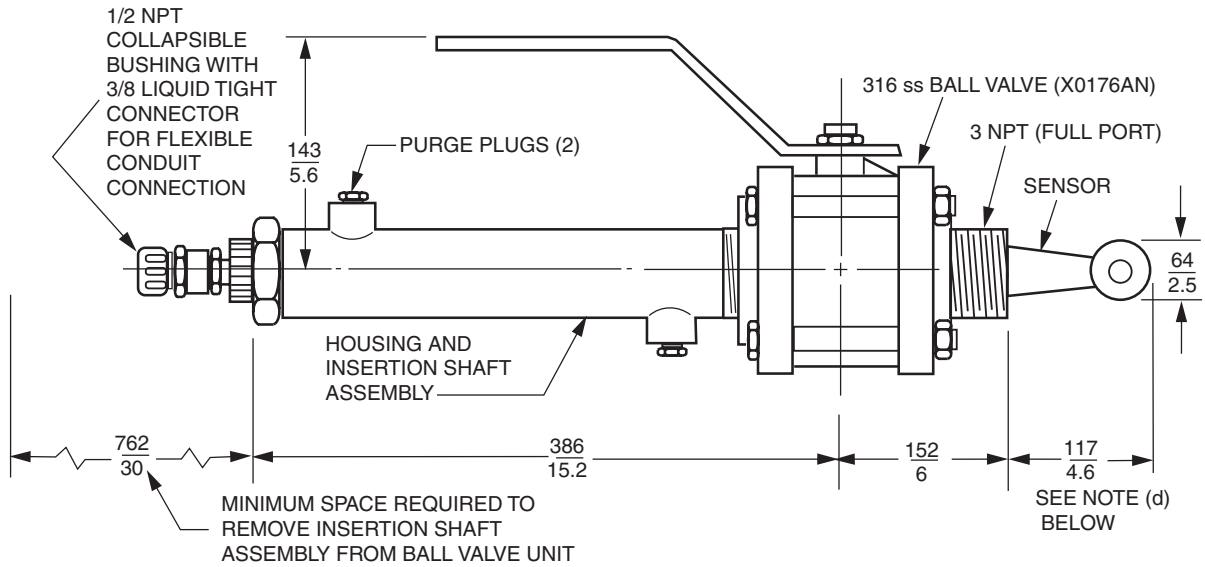

Ball Valve Assembly Part No.(a)	Housing Assembly 316 ss (b)	Purge Plug Part No. (316 ss)	Valve Material		Insertion Shaft(d)		
			Body	Seat and O-Ring Seal (c)	Mat'l	O-Ring Seals	Length
BS806GE	Purgeable (b)	D0116KZ (316 ss)	316 ss	Reinforced ptfe (c)	316 ss	EPDM	$\frac{461}{18.2}$

- (a) Ball Valve Assembly includes ball valve, housing, and insertion shaft assemblies. See figure above for ball valve part number.
- (b) Nonpurgeable housing assembly is not offered with the 3-inch ball valve assembly.
- (c) ptfe = polytetrafluoroethylene (such as Teflon™).
- (d) Longer insertion lengths ("B") are available by using longer insertion shafts; contact Foxboro.

ORDERING INSTRUCTIONS

1. Sensor Model Number - include optional nonstandard cable lengths and optional O-ring materials. See Items 3 and 4 below.
2. Electrical Safety Design Code
3. Cable Length:
 - Standard cable length is 6 m (20 ft)
 - For nonstandard cable length from 1 to 30 m (3 to 100 ft), specify the applicable cable optional selection in Model Code.
4. O-ring Material:
 - EPDM is standard
 - Chemraz, Kalrez, and Viton are optional selection with certain sensors. Refer to Model Code.
5. Accessories: Refer to Accessories section. Specify mounting hardware, flanges, Tri-clamp kits, ball valve assemblies, junction box, or extension cable (with or without spade lug terminals), as applicable.
6. Customer tag data

PRODUCT PATENT INFORMATION

Patents – High Temperature PEEK Sensors

This product and its components are protected by U.S. Patents 3, 806, 798; 4, 220, 920; 5,157,332; and others pending. Corresponding patents have been issued or are pending in other countries.

Patents – All sensors other than High Temperature PEEK Sensors

This product and its components are protected by the following U.S. Patents: 3, 806, 798; 4, 220, 920; and 5,157,332.

OTHER M&I PRODUCTS

Invensys Foxboro provides a broad range of measurement and instrument products, including solutions for pressure, flow, analytical, positioners, temperature, controlling and recording. For a listing of these offerings, visit the Invensys Foxboro web site at:

www.foxboro.com/instrumentation

33 Commercial Street
Foxboro, MA 02035-2099
United States of America
www.foxboro.com
Inside U.S.: 1-866-746-6477
Outside U.S.: 1-508-549-2424
or contact your local Foxboro
representative.
Facsimile: 1-508-549-4999

Invensys and Foxboro are trademarks of Invensys plc, its subsidiaries, and affiliates.
All other brand names may be trademarks of their respective owners.

Copyright 1992-2005 Invensys Systems, Inc.
All rights reserved

MB 010, 012

Printed in U.S.A.

0305