

# Diaphragm seal with sterile connection For sanitary applications Model 990.17, DRD connection

WIKA data sheet DS 99.39



for further approvals  
see page 3

## Applications

- Food and beverage production
- Dairies, dairy products
- Breweries
- Soft drink production
- For storage vessels

## Special features

- Quick cleaning of measuring point, without residue
- Suitable for SIP and CIP
- 3-A compliant

## Description

Diaphragm seals are used to protect the pressure measuring instrument from aggressive, adhesive, crystallising, corrosive, highly viscous, environmentally hazardous or toxic media. A diaphragm made of the appropriate material provides for the separation from the medium to be measured. Thus even the most difficult measuring requirements can be met by combining measuring instruments with diaphragm seals.

A fluid inside the system, which can be chosen to suit the particular application, hydraulically transmits the pressure to the measuring instrument.

Almost limitless application possibilities exist due to the large number of available variants, such as diaphragm seal designs or materials. The type of process connection (flange, threaded and sterile connection) and the basic method of manufacture are important design differentiation criteria.

For further technical information on diaphragm seals and diaphragm seal systems see IN 00.06 "Application, operating principle, designs".



**Fig. top: Diaphragm seal with sterile connection, model 990.17**

**Fig. bottom: Welding flange with DRD connection for diaphragm seal model 990.17**

The model 990.17 diaphragm seal with DRD connection fulfils the high standard requirements of sanitary applications. It can be integrated into tanks and storage vessels via a welding flange. The diaphragm seal systems can withstand the cleaning vapour temperatures occurring in the SIP processes and thus ensure a sterile connection between the medium to be measured and the diaphragm seal.

Assembly of the diaphragm seal and measuring instrument is made via a direct assembly as standard or optionally via a cooling element or a flexible capillary.

For the material selection WIKA offers a variety of solutions, in which the upper body and the diaphragm are made of identical materials. Stainless steel 316L (1.4435) is used as standard material, other special materials are available on request.

Measuring systems with the model 990.17 WIKA diaphragm seal are successfully used primarily for hydrostatic level measurement.

## Standard version

### Type of process connection

For welding flanges with DRD connection

### Nominal pressure

PN 40

### Measuring ranges

min. 0 ... 1 bar, max. 0 ... 40 bar

(also vacuum and +/- measuring ranges)

### Material of upper body

Stainless steel 1.4435 (316L)

### Material of wetted parts

Diaphragm: Stainless steel 1.4435 (316L)

### Assembly parts

Retainer flange stainless steel 1.4435 (316L)

Hexagon bolts stainless steel M10 x 20

### Surface roughness of wetted parts

$R_a \leq 0.76 \mu\text{m}$  per ASME BPE SF3 (except for weld seam)

### Level of cleanliness of wetted parts

Oil and grease free per ASTM G93-03 level E (WIKA standard) and ISO 15001 ( $< 550 \text{ mg/m}^2$ )

### Connection to the measuring instrument

Axial weld-in connection

## Options

- Surface roughness of wetted parts  
 $R_a \leq 0.38 \mu\text{m}$  per ASME BPE SF4, only with electropolished surface (except for weld seam)
- Sealing from EPDM or PTFE
- DRD welding flange with weld contour from stainless steel 1.4435 (316L)
- Connection to the measuring instrument  
G 1/2, G 1/4, 1/2 NPT or 1/4 NPT (female)
- Origin of wetted parts (EU, CH, USA)
- Marking of the diaphragm seal with 3-A standard 74-05

## Installation example

Diaphragm seal, sterile connection, model 990.17 with directly assembled pressure gauge on a pipe socket

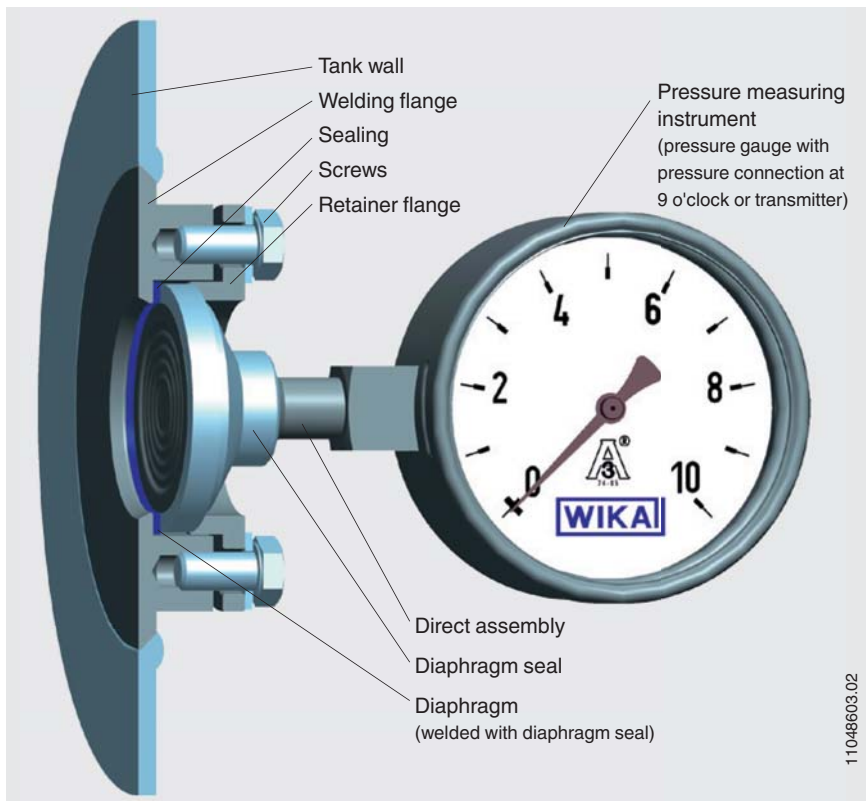

The graph shows the installation with welding flange in a vertical tank wall.

The measuring assembly is self-draining, with a recommended mounting position in accordance with 3-A standard 74-05.

## Additional information for diaphragm seal systems

See Technical information IN 00.06 “Diaphragm seals - Diaphragm seal systems, application, operating principle, designs”

- Pressure measuring instrument model
- Connection to the measuring instrument: Direct assembly (calibrated in vertical mounting position, process connection facing downwards)
- Process temperature
- Ambient temperature
- System fill fluid
  - Recommendation for the food and beverage production: Neobee® KN 59 (FDA 21 CFR 172.856, 21 CFR 174.5)
  - Recommendation for pharmaceutical and cosmetics applications: Medicinal white mineral oil KN 92 (FDA 21 CFR 172.878, 21 CFR 178.3620(a); USP, EP)

## Options for diaphragm seal systems

- Connection to the measuring instrument via cooling element or capillary
- Vacuum service (suitable for vacuum operation)
- Higher level of cleanliness of wetted parts  
Oil and grease free per ASTM G93-03 level C and ISO 15001 (< 66 mg/m<sup>2</sup>)
- Height difference between measuring point and pressure measuring instrument with capillary in metre increments (max. 7 m with silicone oils/edible oils)
- Mounting bracket (required for connection to the measuring instrument via capillary, model 910.16, data sheet AC 09.07)
  - Form H per DIN 16281, 100 mm, aluminium, black
  - Form H per DIN 16281, 100 mm, stainless steel
  - Bracket for pipe mounting, for pipe Ø 20 ... 80 mm, steel

## Materials

Upper body	Wetted part Diaphragm
Standard	
Stainless steel 1.4435 (316L)	Stainless steel 1.4435 (316L)

Further material combinations on request

## Approvals

- **GOST-R**, import certificate, Russia
- **CRN**, safety (e.g. electr. safety, overpressure, ...), Canada

## Certificates <sup>1)</sup>

- 2.2 test report per EN 10204 (e.g. state-of-the-art manufacturing, material proof, indication accuracy for diaphragm seal systems)
- 3.1 inspection certificate per EN 10204 (e.g. material proof for wetted metallic parts, indication accuracy for diaphragm seal systems)
- FDA conformity of the system fill fluid
- 3-A conformity of the diaphragm seal, based on a third party verification, in accordance with 3-A standard 74-05
- Manufacturer's declaration regarding EU regulation 1935/2004 EC
- Others on request

<sup>1)</sup> Option

Approvals and certificates, see website

## Dimensions in mm

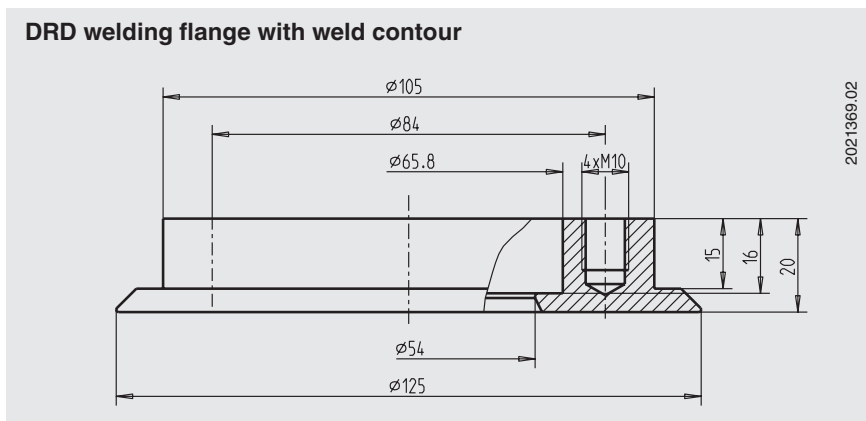
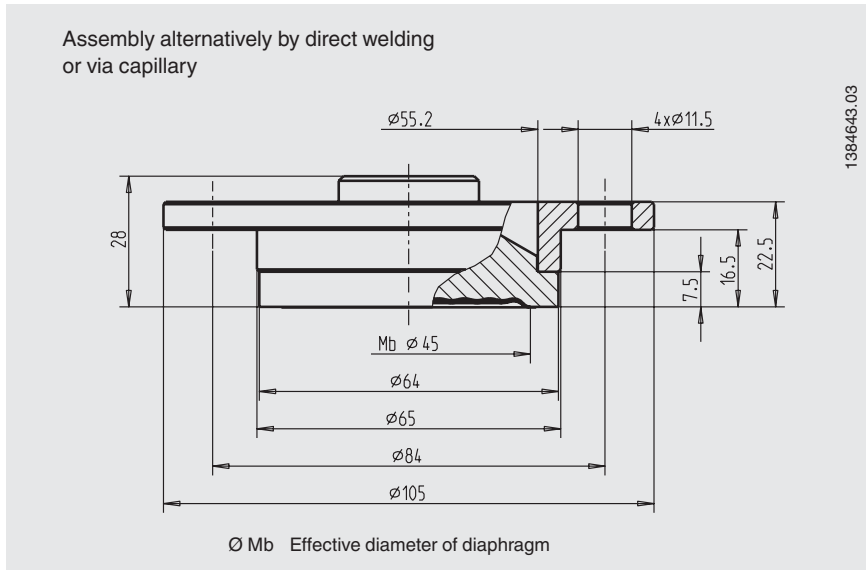

### Ordering information

Diaphragm seal:

Diaphragm seal model / Process connection (specification of process connection) / Material (upper body, diaphragm) / Surface roughness of wetted parts / Sealing / Welding flange / Connection to the measuring instrument / Level of cleanliness of wetted parts / Origin of wetted parts / Certificates

Diaphragm seal system:

Diaphragm seal model / Process connection (specification of process connection) / Material (upper body, diaphragm) / Surface roughness of wetted parts / Sealing / Welding flange / Pressure measuring instrument model (per data sheet) / Assembly (direct assembly, cooling element, capillary) / min. and max. process temperature / min. and max. ambient temperature / Vacuum service / System fill fluid / Certificates / Height difference / Level of cleanliness of wetted parts / Origin of wetted parts / Mounting bracket

© 2006 WIKA Alexander Wiegand SE & Co. KG, all rights reserved.  
The specifications given in this document represent the state of engineering at the time of publishing.  
We reserve the right to make modifications to the specifications and materials.

