

# Sterile Process Connection, Diaphragm Seals For Aseptic, Chemical and Pharmaceutical Industry

## Aseptic connection per DIN 11 864, Model 990.51

WIKA Data Sheet DS 99.51



### Applications

- Food and beverage industry
- Biochemical and pharmaceutical industry, production of active ingredients
- Aseptic raw element production in the chemical industry

### Special Features

- Quick measuring point cleaning without residues
- Suitable for SIP and CIP
- 3A certified and FDA approved
- Flush welded diaphragm



Diaphragm Seal, Aseptic Threaded Connection Model 990.51  
left with Pressure Gauge and right with Transmitter

### Description

#### Process connection

Aseptic threaded pipe connection per DIN 11 864-1  
Aseptic flanged connection per DIN 11 864-2  
Aseptic clamp connection per DIN 11 864-3  
Nominal sizes (DN) see dimensions starting page 3

#### Pressure rating

see dimensions starting page 3

#### Suitable pressure ranges

0 ... 0.6 bar to 0 ... 25 or 40 bar

#### Material of wetted parts

Stainless steel 1.4435 (316L)

#### Instrument connection

Gauges directly welded, transmitter with threaded adaptor

#### System fill fluid

KN 62 Liquid Paraffin (medical white oil), pharmaceutical compatible, FDA approved, according to standard USP XXIII, EP (1993), JP XII and NSF (H1)



Fig. left: Model 990.51, Aseptic Flanged Connection  
Fig. right: Model 990.51, Aseptic Clamp Connection with Pressure Gauge Model 232.50 NS 160

## Optional extras

### Process connection

- Other nominal sizes (DN) and further aseptic process connections on inquiry

### Pressure rating

- Higher pressure ratings on inquiry

### Material of wetted parts

- Stainless steel 1.4435 electropolished
- Stainless steel 1.4439
- Special materials on inquiry

### Surface roughness and design

- Hygienic standard H4 per DIN 11864, surface roughness of wetted parts  $Ra < 0.4 \mu m$

### Pressure instrument assembly

- Assembly via cooling tower
- Assembly via capillary, when ordering please specify: length of capillary

### System fill fluid

- KN 7 Glycerine, FDA approved
- KN 12 Glycerine/water, FDA approved
- KN 59 Neobee® M-20, FDA approved

### Documentation

- Material certificate per 2.2 or 3.1 per DIN 10 204
- Test and calibration certificates
- Pressure and stability tests
- Confirmation of FDA approval
- 3-A symbol and approval certificate

Further certificates and documents on request

## Aseptic threaded pipe connection per DIN 11 864-1

Example for mounting at a pipe socket of a diaphragm seal model 990.51 union nut for threaded pipe connection DIN 11 864-1 form A (O-ring) directly connected on pressure gauge

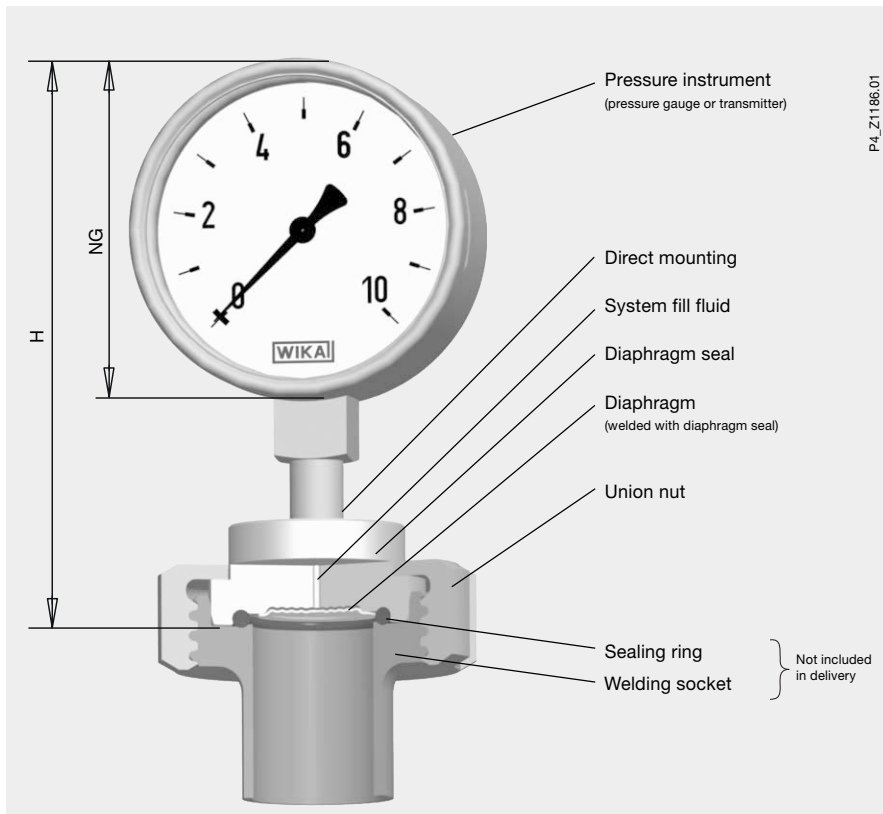

| Pressure instrument<br>Nominal size | Dimensions in mm<br>Installation height H |
|-------------------------------------|---|
| NS 63                               | approx. 105                               |
| NS 100                              | approx. 156                               |

## Dimensions in mm

### Model 990.51 for aseptic threaded pipe connection DIN 11 864-1 form A (O-ring)

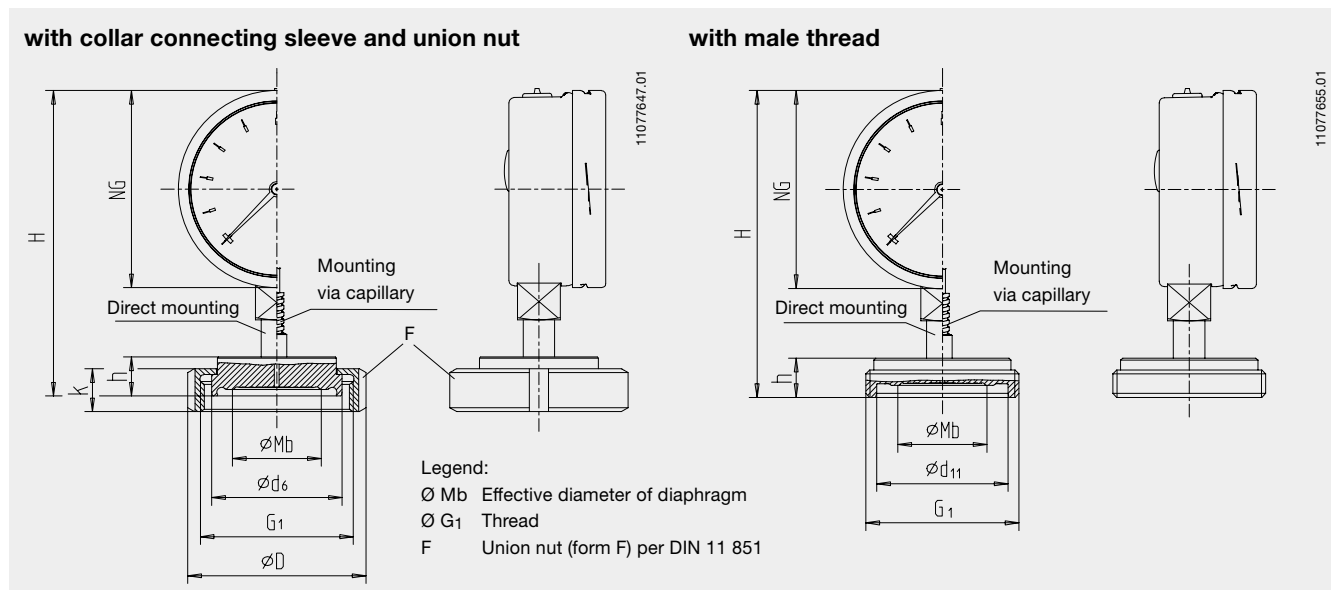

Dimensions for corresponding pipes per DIN 11 866 - column A (pipe dimensions per DIN 11 850)

| DN  | For pipe<br>Outside $\varnothing$ x 1)<br>thickness | PN | Dimensions in mm |                |                 |                |    |        |     | Weight in kg |                   |                      |                |
|-----|---|----|------------------|----------------|-----------------|----------------|----|--------|-----|--------------|-------------------|----------------------|----------------|
|     |   |    | Mb               | d <sub>6</sub> | d <sub>11</sub> | G <sub>1</sub> | h  | F      | D   | k            | Aseptic<br>O-ring | Connecting<br>sleeve | Male<br>thread |
| 25  | 29 x 1.5  | 40 | 22               | 42.9           | 43              | RD 52 x 1/6    | 20 | DN 25  | 63  | 21           | 28 x 3.5          | 1.0                  | 0.9            |
| 32  | 35 x 1.5  | 40 | 25               | 48.9           | 49              | RD 58 x 1/6    | 20 | DN 32  | 70  | 21           | 34 x 5            | 1.2                  | 1.2            |
| 40  | 41 x 1.5  | 40 | 35               | 54.9           | 55              | RD 65 x 1/6    | 20 | DN 40  | 78  | 21           | 40 x 5            | 1.5                  | 1.5            |
| 50  | 53 x 1.5  | 25 | 45               | 66.9           | 67              | RD 78 x 1/6    | 20 | DN 50  | 92  | 22           | 52 x 5            | 2.2                  | 2.3            |
| 65  | 70 x 2.0  | 25 | 60               | 84.9           | 85              | RD 95 x 1/6    | 20 | DN 65  | 112 | 25           | 68 x 5            | 3.6                  | 3.6            |
| 80  | 85 x 2.0  | 25 | 72               | 98.9           | 99              | RD 110 x 1/4   | 20 | DN 80  | 127 | 29           | 83 x 5            | 5.0                  | 4.9            |
| 100 | 104 x 2.0   | 25 | 90               | 118.9          | 119             | RD 130 x 1/4   | 20 | DN 100 | 148 | 31           | 102 x 5           | 7.1                  | 7.1            |

Dimensions for corresponding pipes per DIN 11 866 - column B (pipe dimensions per DIN EN ISO 1127)

| DN   | For pipe<br>Outside $\varnothing$ x 1)<br>thickness | PN | Dimensions in mm |                |                 |                |    |        |     | Weight in kg |                   |                      |                |
|------|---|----|------------------|----------------|-----------------|----------------|----|--------|-----|--------------|-------------------|----------------------|----------------|
|      |   |    | Mb               | d <sub>6</sub> | d <sub>11</sub> | G <sub>1</sub> | h  | F      | D   | k            | Aseptic<br>O-ring | Connecting<br>sleeve | Male<br>thread |
| 26.9 | 26.9 x 1.6  | 40 | 22               | 42.9           | 43              | RD 52 x 1/6    | 20 | DN 25  | 63  | 21           | 26 x 3.5          | 1.0                  | 0.9            |
| 33.7 | 33.7 x 2.0  | 40 | 25               | 48.9           | 49              | RD 58 x 1/6    | 20 | DN 32  | 70  | 21           | 32 x 5            | 1.2                  | 1.2            |
| 42.4 | 42.4 x 2.0  | 25 | 35               | 54.9           | 55              | RD 65 x 1/6    | 20 | DN 40  | 78  | 21           | 40.5 x 5          | 1.5                  | 1.5            |
| 48.3 | 48.3 x 2.0  | 25 | 45               | 66.9           | 67              | RD 78 x 1/6    | 20 | DN 50  | 92  | 22           | 46.5 x 5          | 2.2                  | 2.3            |
| 60.3 | 60.3 x 2.0  | 25 | 60               | 84.9           | 85              | RD 95 x 1/6    | 20 | DN 65  | 112 | 25           | 58.5 x 5          | 3.6                  | 3.6            |
| 76.1 | 76.1 x 2.0  | 25 | 72               | 98.9           | 99              | RD 110 x 1/4   | 20 | DN 80  | 127 | 29           | 73.5 x 5          | 5.0                  | 4.9            |
| 88.9 | 88.9 x 2.3  | 25 | 90               | 118.9          | 119             | RD 130 x 1/4   | 20 | DN 100 | 148 | 31           | 86.5 x 5          | 7.1                  | 7.1            |

Dimensions for corresponding pipes per DIN 11 866 - column C (pipe dimensions per ASME BPE 1997)

| DN     | For pipe<br>Outside $\varnothing$ x 1)<br>thickness | PN | Dimensions in mm |                |                 |                |    |        |     | Weight in kg |                   |                      |                |
|--------|---|----|------------------|----------------|-----------------|----------------|----|--------|-----|--------------|-------------------|----------------------|----------------|
|        |   |    | Mb               | d <sub>6</sub> | d <sub>11</sub> | G <sub>1</sub> | h  | F      | D   | k            | Aseptic<br>O-ring | Connecting<br>sleeve | Male<br>thread |
| 1"     | 25.4 x 1.65   | 40 | 22               | 42.9           | 43              | RD 52 x 1/6    | 20 | DN 25  | 63  | 21           | 24 x 3.5          | 1.0                  | 0.9            |
| 1 1/2" | 38.1 x 1.65   | 40 | 32               | 54.9           | 55              | RD 58 x 1/6    | 20 | DN 40  | 78  | 21           | 37 x 5            | 1.5                  | 1.5            |
| 2"     | 50.8 x 1.65   | 25 | 45               | 66.9           | 67              | RD 65 x 1/6    | 20 | DN 50  | 92  | 22           | 50 x 5            | 2.2                  | 2.3            |
| 2 1/2" | 63.5 x 1.65   | 25 | 52               | 84.9           | 85              | RD 78 x 1/6    | 20 | DN 65  | 112 | 25           | 62 x 5            | 3.6                  | 3.6            |
| 3"     | 76.2 x 1.65   | 25 | 60               | 98.9           | 99              | RD 95 x 1/6    | 20 | DN 80  | 127 | 29           | 75 x 5            | 5.0                  | 4.9            |
| 4"     | 101.6 x 2.11  | 25 | 90               | 118.9          | 119             | RD 130 x 1/4   | 20 | DN 100 | 148 | 31           | 100 x 5           | 7.1                  | 7.1            |

1) Permissible pressure in bar; pressure may only be applied together with use of the appropriate O-ring material up to temperatures of -10 ... +140°C

## Dimensions in mm

### Model 990.51 for aseptic flanged connection per DIN 11 864-2 form A (O-ring)

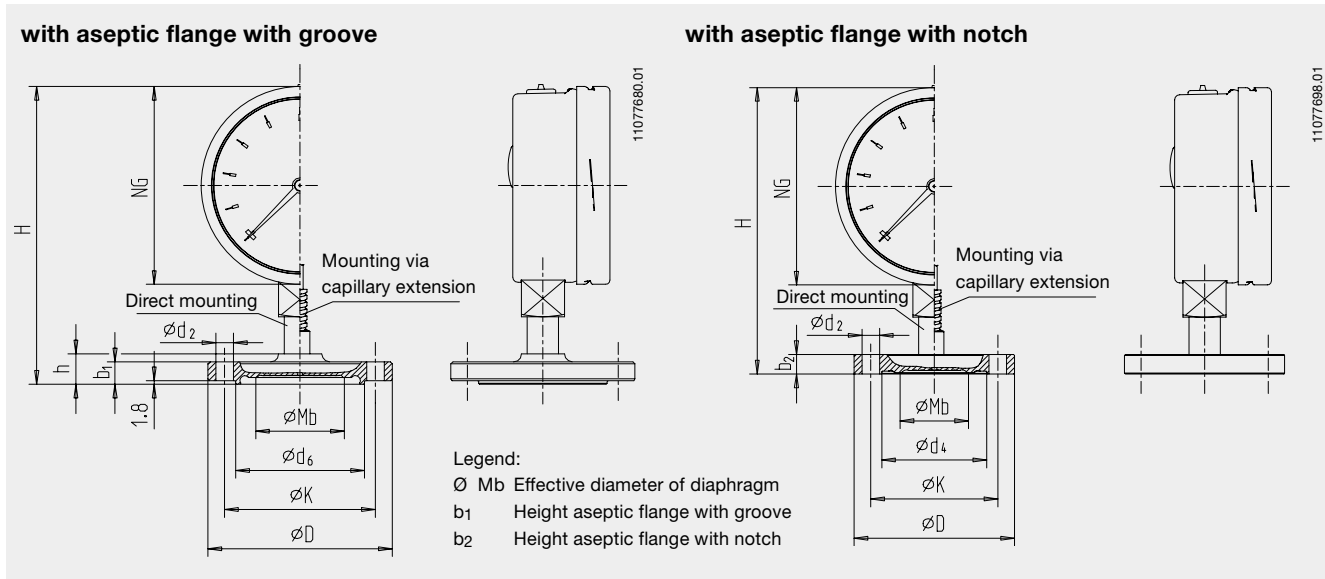

#### Dimensions for corresponding pipes per DIN 11 866 - column A (pipe dimensions per DIN 11 850)

| DN  | For pipe<br>Outside $\varnothing$ x 1)<br>thickness | PN | Dimensions in mm |                |                |     |     |      |                |                | Aseptic<br>O-ring    | Weight in kg   |                       |                      |
|-----|---|----|------------------|----------------|----------------|-----|-----|------|----------------|----------------|----------------------|----------------|-----------------------|----------------------|
|     |   |    | Mb               | d <sub>6</sub> | d <sub>4</sub> | K   | D   | h    | b <sub>1</sub> | b <sub>2</sub> |                      | d <sub>2</sub> | Flange<br>with groove | Flange<br>with notch |
| 25  | 29 x 1.5  | 25 | 22               | 38.3           | 38.4           | 53  | 70  | 15.5 | 11.5           | 10             | 4 x $\varnothing 9$  | 28 x 3.5       | 1.4                   | 1.2                  |
| 32  | 35 x 1.5  | 25 | 25               | 47.6           | 47.7           | 59  | 76  | 15.5 | 11.5           | 10             | 4 x $\varnothing 9$  | 34 x 5         | 1.7                   | 1.5                  |
| 40  | 41 x 1.5  | 25 | 35               | 53.6           | 53.7           | 65  | 82  | 15.5 | 11.5           | 10             | 4 x $\varnothing 9$  | 40 x 5         | 1.9                   | 1.7                  |
| 50  | 53 x 1.5  | 16 | 45               | 65.6           | 65.7           | 77  | 94  | 15.5 | 11.5           | 10             | 4 x $\varnothing 9$  | 52 x 5         | 2.6                   | 2.2                  |
| 65  | 70 x 2.0  | 16 | 60               | 81.6           | 81.7           | 95  | 113 | 15.5 | 11.5           | 10             | 8 x $\varnothing 9$  | 68 x 5         | 3.7                   | 3.2                  |
| 80  | 85 x 2.0  | 16 | 72               | 97.6           | 97.7           | 112 | 133 | 17.5 | 13.5           | 12             | 8 x $\varnothing 11$ | 83 x 5         | 6.0                   | 5.3                  |
| 100 | 104 x 2.0   | 16 | 90               | 116.6          | 116.7          | 137 | 159 | 19.5 | 15.5           | 14             | 8 x $\varnothing 11$ | 102 x 5        | 9.8                   | 8.9                  |

#### Dimensions for corresponding pipes per DIN 11 866 - column B (pipe dimensions per DIN EN ISO 1127)

| DN   | For pipe<br>Outside $\varnothing$ x 1)<br>thickness | PN | Dimensions in mm |                |                |     |     |      |                |                | Aseptic<br>O-ring    | Weight in kg   |                       |                      |
|------|---|----|------------------|----------------|----------------|-----|-----|------|----------------|----------------|----------------------|----------------|-----------------------|----------------------|
|      |   |    | Mb               | d <sub>6</sub> | d <sub>4</sub> | K   | D   | h    | b <sub>1</sub> | b <sub>2</sub> |                      | d <sub>2</sub> | Flange<br>with groove | Flange<br>with notch |
| 26.9 | 26 x 1.6  | 25 | 22               | 36.0           | 36.1           | 52  | 69  | 15.5 | 11.5           | 10             | 4 x $\varnothing 9$  | 26 x 3.5       | 1.4                   | 1.2                  |
| 33.7 | 33.7 x 2.0  | 25 | 25               | 45.3           | 45.4           | 57  | 74  | 15.5 | 11.5           | 10             | 4 x $\varnothing 9$  | 32 x 5         | 1.6                   | 1.4                  |
| 42.4 | 42.4 x 2.0  | 16 | 35               | 54.0           | 54.1           | 65  | 82  | 15.5 | 11.5           | 10             | 4 x $\varnothing 9$  | 40.5 x 5       | 1.9                   | 1.7                  |
| 48.3 | 48.3 x 2.0  | 16 | 40               | 59.9           | 60.0           | 71  | 88  | 15.5 | 11.5           | 10             | 4 x $\varnothing 9$  | 46.5 x 5       | 2.2                   | 1.9                  |
| 60.3 | 60.3 x 2.0  | 16 | 52               | 71.9           | 72.0           | 85  | 103 | 15.5 | 11.5           | 10             | 8 x $\varnothing 9$  | 58.5 x 5       | 3.1                   | 2.7                  |
| 76.1 | 76.1 x 2.0  | 16 | 60               | 88.1           | 88.1           | 104 | 125 | 17.5 | 13.5           | 12             | 8 x $\varnothing 11$ | 73.5 x 5       | 5.3                   | 4.7                  |
| 88.9 | 88.9 x 2.3  | 16 | 72               | 100.9          | 101.0          | 116 | 137 | 17.5 | 13.5           | 12             | 8 x $\varnothing 11$ | 86.5 x 5       | 6.4                   | 5.7                  |

#### Dimensions for corresponding pipes per DIN 11 866 - column C (pipe dimensions per ASME BPE 1997)

| DN     | For pipe<br>Outside $\varnothing$ x 1)<br>thickness | PN | Dimensions in mm |                |                |     |     |      |                |                | Aseptic<br>O-ring    | Weight in kg   |                       |                      |
|--------|---|----|------------------|----------------|----------------|-----|-----|------|----------------|----------------|----------------------|----------------|-----------------------|----------------------|
|        |   |    | Mb               | d <sub>6</sub> | d <sub>4</sub> | K   | D   | h    | b <sub>1</sub> | b <sub>2</sub> |                      | d <sub>2</sub> | Flange<br>with groove | Flange<br>with notch |
| 1"     | 25.4 x 1.65   | 25 | 22               | 34.3           | 34.4           | 49  | 66  | 15.5 | 11.5           | 10             | 4 x $\varnothing 9$  | 24 x 3.5       | 1.3                   | 1.1                  |
| 1 1/2" | 38.1 x 1.65   | 25 | 32               | 50.4           | 50.4           | 62  | 79  | 15.5 | 11.5           | 10             | 4 x $\varnothing 9$  | 37 x 5         | 1.8                   | 1.6                  |
| 2"     | 50.8 x 1.65   | 16 | 45               | 63.4           | 63.5           | 75  | 92  | 15.5 | 11.5           | 10             | 4 x $\varnothing 9$  | 50 x 5         | 2.4                   | 2.1                  |
| 2 1/2" | 63.5 x 1.65   | 16 | 52               | 75.8           | 75.9           | 89  | 107 | 15.5 | 11.5           | 10             | 4 x $\varnothing 9$  | 62 x 5         | 3.3                   | 2.9                  |
| 3"     | 76.2 x 1.65   | 16 | 60               | 89.5           | 89.6           | 104 | 125 | 17.5 | 13.5           | 12             | 8 x $\varnothing 11$ | 75 x 5         | 5.3                   | 4.7                  |
| 4"     | 101.6 x 2.11  | 16 | 90               | 114.2          | 114.3          | 135 | 157 | 19.5 | 15.5           | 14             | 8 x $\varnothing 11$ | 100 x 5        | 9.6                   | 8.7                  |

1) Permissible pressure in bar; pressure may only be applied together with use of the appropriate O-ring material up to temperatures of -10 ... +140°C

## Dimensions in mm

### Model 990.51 Aseptic clamp connection DIN 11 864-3 form A (O-ring)

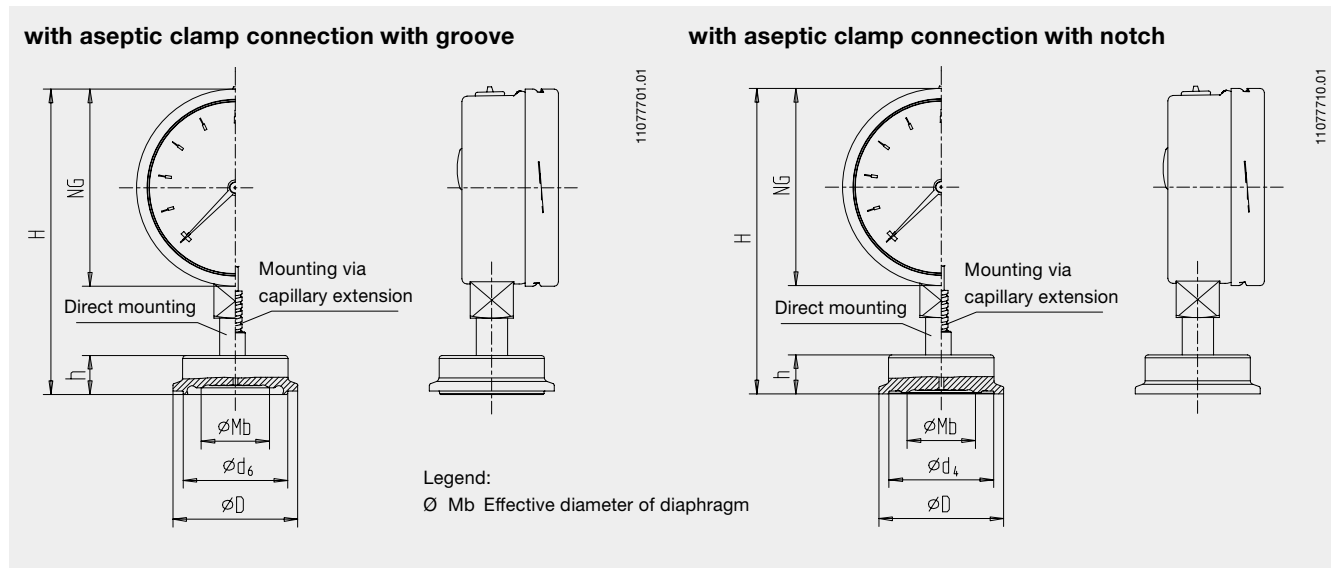

Dimensions for corresponding pipes per DIN 11 866 - column A (pipe dimensions per DIN 11 850)

| DN  | For pipe<br>Outside Ø x<br>thickness | PN<br>1) | Dimensions in mm |                |                |      |      | h        | Aseptic<br>O-ring | Weight in kg |
|-----|--------------------------------------|----------|------------------|----------------|----------------|------|------|----------|-------------------|--------------|
|     |                                      |          | Mb               | d <sub>6</sub> | d <sub>4</sub> | D    | D    |          |                   |              |
| 25  | 29 x 1.5                             | 40       | 22               | 38.3           | 38.4           | 50.5 | 20   | 28 x 3.5 | 0.7               |              |
| 32  | 35 x 1.5                             | 40       | 25               | 47.6           | 47.7           | 50.5 | 20   | 34 x 5   | 1.1               |              |
| 40  | 41 x 1.5                             | 40       | 35               | 53.6           | 53.7           | 64   | 20   | 40 x 5   | 1.4               |              |
| 50  | 53 x 1.5                             | 25       | 45               | 65.6           | 65.7           | 77.5 | 20   | 52 x 5   | 2.2               |              |
| 65  | 70 x 2.0                             | 25       | 60               | 81.6           | 81.7           | 91   | 20   | 68 x 5   | 3.3               |              |
| 80  | 85 x 2.0                             | 16       | 72               | 97.6           | 97.7           | 106  | 20   | 83 x 5   | 4.8               |              |
| 100 | 104 x 2.0                            | 16       | 90               | 116.6          | 116.7          | 130  | 21.5 | 102 x 5  | 7.3               |              |

Dimensions for corresponding pipes per DIN 11 866 - column B (pipe dimensions per DIN EN ISO 1127)

| DN   | For pipe<br>Outside Ø x<br>thickness | PN<br>1) | Dimensions in mm |                |                |      |      | h        | Aseptic<br>O-ring | Weight in kg |
|------|--------------------------------------|----------|------------------|----------------|----------------|------|------|----------|-------------------|--------------|
|      |                                      |          | Mb               | d <sub>6</sub> | d <sub>4</sub> | D    | D    |          |                   |              |
| 26.9 | 26.9 x 1.6                           | 40       | 22               | 36.0           | 36.1           | 50.5 | 20   | 26 x 3,5 | 0.7               |              |
| 33.7 | 33.7 x 2.0                           | 40       | 25               | 45.3           | 45.3           | 50.5 | 20   | 32 x 5   | 1.0               |              |
| 42.4 | 42.4 x 2.0                           | 25       | 35               | 54.0           | 54.1           | 64   | 20   | 40.5 x 5 | 1.5               |              |
| 48.3 | 48.3 x 2.0                           | 25       | 40               | 59.9           | 60.0           | 64   | 20   | 46.5 x 5 | 1.8               |              |
| 60.3 | 60.3 x 2.0                           | 25       | 52               | 71.9           | 72.0           | 91   | 20   | 58.5 x 5 | 2.6               |              |
| 76.1 | 76.1 x 2.0                           | 16       | 60               | 88.1           | 88.2           | 106  | 20   | 73.5 x 5 | 3.9               |              |
| 88.9 | 88.9 x 2.3                           | 16       | 72               | 100.9          | 101.0          | 119  | 22.5 | 86.5 x 5 | 5.8               |              |

Dimensions for corresponding pipes per DIN 11 866 - column C (pipe dimensions per ASME BPE 1997)

| DN     | For pipe<br>Outside Ø x<br>thickness | PN<br>1) | Dimensions in mm |                |                |      |    | h        | Aseptic<br>O-ring | Weight in kg |
|--------|--------------------------------------|----------|------------------|----------------|----------------|------|----|----------|-------------------|--------------|
|        |                                      |          | Mb               | d <sub>6</sub> | d <sub>4</sub> | D    | D  |          |                   |              |
| 1"     | 25.4 x 1.65                          | 40       | 22               | 34.3           | 34.4           | 50.5 | 20 | 24 x 3.5 | 0.6               |              |
| 1 1/2" | 38.1 x 1.65                          | 40       | 32               | 50.4           | 50.5           | 64   | 20 | 37 x 5   | 1.3               |              |
| 2"     | 50.8 x 1.65                          | 25       | 45               | 63.4           | 63.5           | 77.5 | 20 | 50 x 5   | 2.0               |              |
| 2 1/2" | 63.5 x 1.65                          | 25       | 52               | 75.8           | 75.9           | 91   | 20 | 62 x 5   | 2.9               |              |
| 3"     | 76.2 x 1.65                          | 16       | 60               | 89.5           | 89.6           | 106  | 20 | 75 x 5   | 4.0               |              |
| 4"     | 101.6 x 2.11                         | 16       | 90               | 114.2          | 114.3          | 130  | 21 | 100 x 5  | 6.9               |              |

1) Permissible pressure in bar; pressure may only be applied together with use of the appropriate O-ring material up to temperatures of -10 ... +140°C

## Pressure measurement

### Bourdon tube pressure gauges

Possibilities for combination with pressure gauge

- Stainless steel version  
Model 232.50/233.50,  
without/with liquid filling  
(see data sheet PM 02.02)



- Stainless steel, safety pattern version  
Model 232.30/233.30,  
without/with liquid filling  
(see data sheet PM 02.04)



if the following application conditions are taken into account:

- Pressure gauge directly combined with diaphragm seal
- Temperature range  
process: +10 ... +150 °C  
ambient: +10 ... +40 °C

| Choice  | Model | Process connection with DN  |                             |                               |                                 |
|---|-------|-----------------------------|-----------------------------|-------------------------------|---------------------------------|
|   |       | 25 ... 33,7 (1")            | 40 (1 1/2") ... 50 (2")     | 60,3 ... 76,1 (2 1/2")        | 80 (3") ...                     |
| Pressure gauge  |       | 23x.50.63<br>23x.50.100     | 23x.50.63<br>23x.50.100     | 23x.50.63<br>23x.50/30.100    | 23x.50.63<br>23x.50/30.100      |
| Lowest measuring range  |       | 0 ... 4 bar<br>-1 ... 3 bar | 0 ... 2 bar<br>-1 ... 3 bar | 0 ... 1 bar<br>-1 ... 1.5 bar | 0 ... 0.6 bar<br>-1 ... 1.5 bar |
| Overpressure safety (optional)  |       | -                           | 2 x full scale value        | 2 x full scale value          | 2 x full scale value            |
| Inductive alarm sensors (optional), suitable in zone 1 and zone 2 (Model 831) |       | -                           | possible                    | possible                      | possible                        |

### Pressure transmitters

For the combination with

- Pressure transmitter for general applications Model S-10, (see data sheet PE 81.01)



- Universal transmitter UniTrans, Model UT-10 / IUT-10, (see data sheet PE 86.01 / PE 86.02)



- or with Process pressure transmitter, Model IPT-10, (see data sheet PE 86.11)



The following lowest pressure ranges apply taking the above mentioned application conditions into account:

| Choice                 | Process connection with DN |                         |                        |                |
|------------------------|----------------------------|-------------------------|------------------------|----------------|
|                        | 25 ... 33,7 (1")           | 40 (1 1/2") ... 50 (2") | 60,3 ... 76,1 (2 1/2") | 80 (3") ...    |
| Lowest measuring range | 0 ... 2.5 bar              | 0 ... 1 bar             | 0 ... 600 mbar         | 0 ... 400 mbar |

Further gauge variants and lower pressure ranges can be supplied after technical verification and clarification by WIKA.

### Ordering information

Model / Connection design / Gasket form / corresponding pipe standard / Process connection / Material of wetted parts / Assembly, if necessary length of capillary / System fill fluid / Pressure gauge model / Process conditions as per questionnaire / Optional extras resp. special version required

Modifications may take place and materials specified may be replaced by others without prior notice. Specifications and dimensions given in this leaflet represent the state of engineering at the time of printing.

