

Hydraulic pressure balance Model CPB5800



WIKA data sheet CT 31.11

Applications

- Primary standard for defining the pressure scale in a range up to 1,400 bar hydraulic
- Reference instrument for factory and calibration laboratories for the testing, adjustment and calibration of pressure measuring instruments
- Complete, stand-alone system, also suitable for on-site use

Special features

- Total measurement uncertainty to 0.006 % of measured value
- Dual-range piston-cylinder system with fully automated changing between ranges
- Factory calibration includes traceability to national standards, as standard; with UKAS or DKD/DAkKS calibration possible as an option
- High long-term stability with recommended recalibration cycle every five years
- Fast and safe replacement of the piston-cylinder system via patented ConTect quick-release system as an option



Model CPB5800 pressure balance

Description

Proven primary standard

Pressure balances are the most accurate instruments available on the market for the calibration of electronic or mechanical pressure measuring instruments. The direct measurement of the pressure ($p = F/A$), as well as the use of high-quality materials enable a very small measurement uncertainty, in conjunction with an excellent long-term stability of five years (recommended in accordance with the German Calibration Service DKD/DAkKS).

The pressure balance has therefore been used for years in factory and calibration laboratories in industry, national institutes and research laboratories.

Stand-alone operation

Due to its integrated pressure generation and the pure mechanical measuring principle, the model CPB5800 is ideal for on-site use for maintenance and service.

Basic principle

Pressure is defined as the quotient of force and area. The core component of the CPB5800 is therefore a very precisely-manufactured piston-cylinder system, which is loaded with masses in order to generate the individual test points.

The masses applied are proportional to the target pressure and this is achieved through optimally graduated masses. As standard, these masses are manufactured to the standard gravity (9.80665 m/s^2), though they can be adjusted to a specific location and also UKAS or DKD/DAkKS calibrated.

The model CPB5800 instrument base

Easy operation

In the stable instrument base, the integrated priming pump and the 250 ml tank enable large test volumes to be easily filled and pressurised. For further pressure increases and fine adjustment, a very precisely-controllable spindle pump is fitted, which only runs within the pump body.

As soon as the measuring system reaches equilibrium, there is a balance of forces between the pressure and the mass load applied. The excellent quality of the system ensures that this pressure remains stable over several minutes, so that the pressure value for comparative measurements can be read without any problems, or also so that more complex adjustments can be carried out on the item under test.

High-performance instrument range

The CPB5800 instrument base is available in 2 variants:

- Standard hydraulic base
 - up to max. 1,200 bar/16,000 psi
 - with integrated pressure generation through priming pump and spindle pump
 - Standard pressure transmission medium: mineral oil, optional: Sebacate oil, brake fluid, Skydrol or Fomblin oil
- Hydraulic high-pressure base
 - up to max. 1,400 bar/20,000 psi
 - with integrated pressure generation through priming pump and spindle pump
 - Pressure transmission medium: mineral oil or Sebacate oil

As standard, both instruments bases are fitted with a connection for the piston-cylinder system with G ¾ male thread.

With the 1,200 bar instrument base, the patented ConTect quick-release mechanism is available as an option. This enables the piston-cylinder system to be changed quickly and safely without any tools.

The connection of the test item is made without tools using a quick-connection. Via the freely-rotating knurled nut, the test item can be oriented as required. As standard, a threaded insert with a G ½ female thread is provided. Other threaded inserts are available to connect the most common pressure measuring instruments.

Standard connection piston-cylinder system

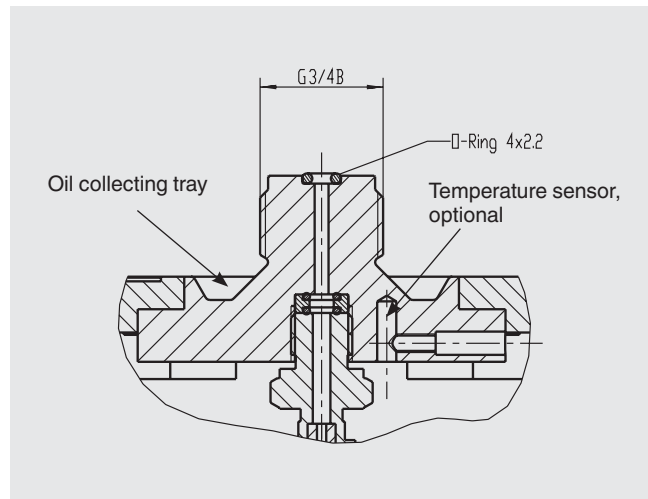

Test item connection

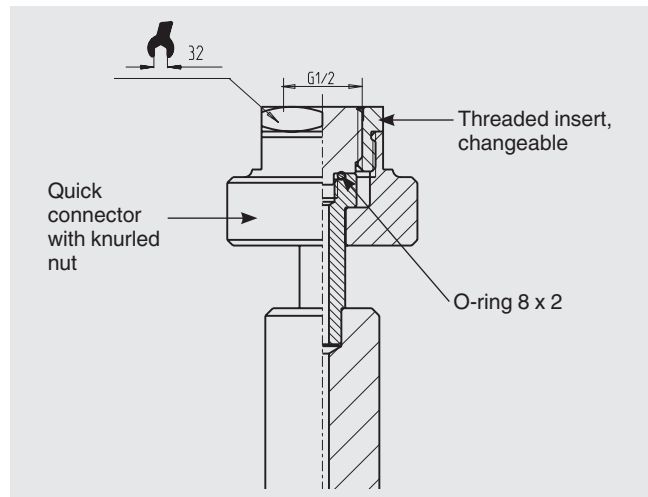

The model CPS5800 piston-cylinder system

The CPS5800 piston-cylinder systems are available in two fundamentally different designs, depending on measuring range.

- Single-range piston-cylinder system (for measuring ranges 120 bar and 300 bar)
- Dual-range piston-cylinder system (for measuring ranges 700 bar, 1,200 bar and 1,400 bar)

High accuracy over a wide measuring range

The dual-range piston-cylinder system offers two measuring ranges in one housing with automatic measuring range switching from low-pressure to high-pressure pistons. This provides the user with an extremely flexible measuring instrument that can cover a wide measuring range with high accuracy, with only one piston-cylinder unit and one set of weights. Additionally two test points can automatically be achieved by the operator loading masses once.

The piston and cylinder are manufactured from hardened steel and tungsten carbide, respectively. This pairing of materials has very low pressure and temperature coefficients of expansion, which results in a very good linearity for the cross-sectional area and a very high accuracy.

Piston and cylinder are very well protected, against contact, impacts or contamination from outside, in a solid stainless-steel/hardened tool steel housing. At the same time, overpressure protection is integrated, which prevents the piston from being forced out vertically and avoids damage to the piston-cylinder system in the event of mass removal under pressure.

The masses are stacked directly onto the piston-cylinder shaft. This makes it easier for the operator to place the masses on and thus enables a lower start value.

The overall design of the piston-cylinder unit and the very precise manufacturing of both the piston and the cylinder, ensure exceptionally low friction force, which results in excellent operating characteristics with long free-rotation time and low sink rates. Thus a high long-term stability is ensured. Therefore the recommended recalibration interval is 5 years depending on the conditions of usage.

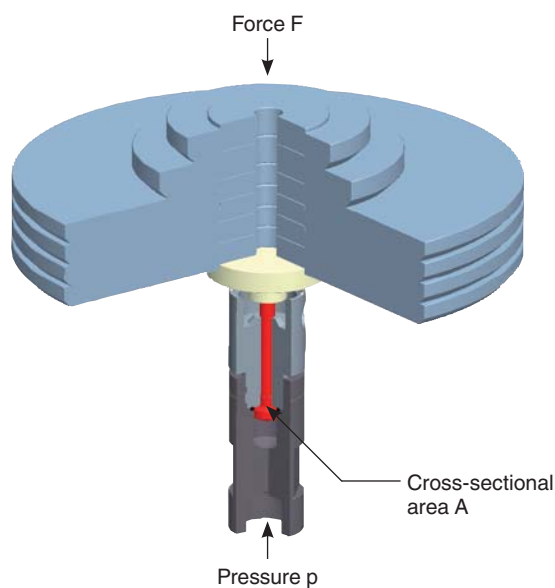

Model CPS5800 single-range piston-cylinder system

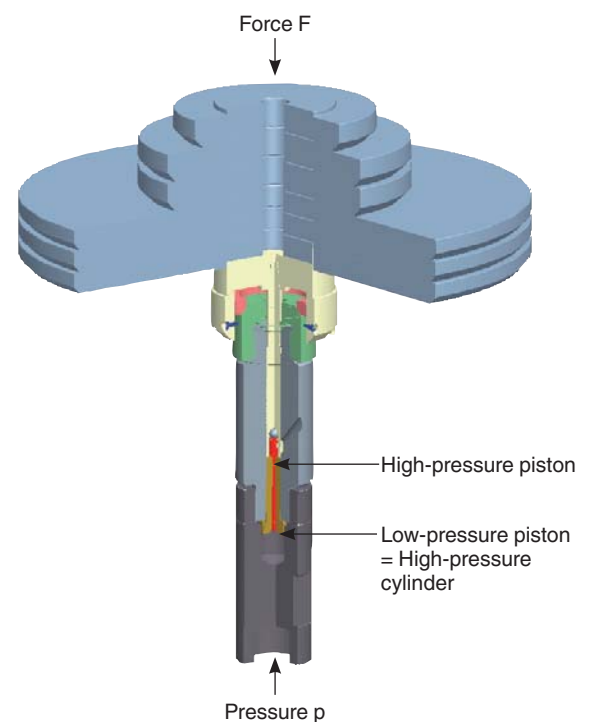

Model CPS5800 dual-range piston-cylinder system

The model CPM5800 mass set

The standard mass set is supplied in a wooden case with a foam insert. This includes the masses listed in the tables of masses below, made from non-magnetic stainless steel, and optimised for everyday use. For finer increments and for a higher resolution, as an option, the standard mass sets can be extended by a set of fine increment weights. If even smaller intermediate values need to be generated, using one of the class M1 or F1 trim-mass sets from the accessories is recommended.



Mass set model CPM5800

Tables of masses

The following tables show, for the respective measuring range, the number of masses within a set of masses, with their resulting nominal pressures.

Should you not operate the instrument under reference conditions (ambient temperature 20 °C, air pressure 1,013 mbar, relative humidity 40 %), the relevant corrections must be made for example with the CPU5000 CalibratorUnit, see page 11.

The masses are manufactured, as standard, to the standard gravity (9.80665 m/s²) although they can be adjusted for any particular location.

The mass sets can be manufactured for the following different pressure units, bar, kg/cm², kPa, MPa or psi and can be used with the same piston-cylinder system.

Measuring range [bar] or [kg/cm ²]	Single-piston measuring ranges				Dual-piston measuring ranges								
	1 ... 120		2 ... 300		1 ... 700		1 ... 1,200		1 ... 1,400		1 ... 1,400		
	Quantity	Nominal pressure per piece	Quantity	Nominal pressure per piece	Quantity	Nominal pressure per piece	Quantity	Nominal pressure per piece	Quantity	Nominal pressure per piece	Quantity	Nominal pressure per piece	
	[bar]	[bar]	[bar]	[bar]	[bar]	[bar]	[bar]	[bar]	[bar]	[bar]	[bar]	[bar]	
	[kg/cm ²]	[kg/cm ²]	[kg/cm ²]	[kg/cm ²]	[kg/cm ²]	[kg/cm ²]	[kg/cm ²]	[kg/cm ²]	[kg/cm ²]	[kg/cm ²]	[kg/cm ²]	[kg/cm ²]	
Piston and make-up weight	1	1	1	2	1	1	10	1	1	20	1	1	20
Standard mass set	4	20	4	50	5	10	100	4	10	200	5	10	200
	1	18	1	45	1	9	90	1	9	180	1	9	180
	1	10	1	25	1	5	50	1	5	100	1	5	100
	2	4	2	10	2	2	20	2	2	40	2	2	40
	1	2	1	5	1	1	10	1	1	20	1	1	20
	2	1	1	3	1	0.5	5	1	0.5	10	1	0.5	10
Fine increment weights (optional)	1	0.5	1	2.5									
	1	0.4	2	1	2	0.2	2	2	0.2	4	2	0.2	4
	1	0.2	1	0.5	1	0.1	1	1	0.1	2	1	0.1	2
	1	0.1	1	0.25	1	0.05	0.5	1	0.05	1	1	0.05	1
	2	0.04	2	0.1	2	0.02	0.2	2	0.02	0.4	2	0.02	0.4
	1	0.02	1	0.05	1	0.01	0.1	1	0.01	0.2	1	0.01	0.2

Measuring range [psi] or [lb/in ²]	Single-piston measuring ranges				Dual-piston measuring ranges								
	10 ... 1,600		30 ... 4,000		10 ... 10,000			10 ... 16,000			10 ... 20,000		
	Quantity	Nominal pressure per piece	Quantity	Nominal pressure per piece	Quantity	Nominal pressure per piece	Nominal pressure per piece	Quantity	Nominal pressure per piece	Nominal pressure per piece	Quantity	Nominal pressure per piece	Nominal pressure per piece
	[psi] [lb/in ²]		[psi] [lb/in ²]		[psi] [lb/in ²]	[psi] [lb/in ²]		[psi] [lb/in ²]	[psi] [lb/in ²]		[psi] [lb/in ²]	[psi] [lb/in ²]	
Piston	1	10			1	10	100	1	10	200	1	10	200
Piston and make-up weight			1	30									
Standard mass set	6	200	6	500	8	100	1,000	6	100	2,000	8	100	2,000
	1	180	1	450	1	90	900	1	90	1,800	1	90	1,800
	1	100	1	250	1	50	500	1	50	1,000	1	50	1,000
	2	40	2	100	2	20	200	2	20	400	2	20	400
	1	20	1	50	1	10	100	1	10	200	1	10	200
	2	10	1	25	1	5	50	1	5	100	1	5	100
	1	5	1	20									
Fine increment weights (optional)	1	4	2	10	2	2	20	2	2	40	2	2	40
	1	2	1	5	1	1	10	1	1	20	1	1	20
	1	1	1	2.5	1	0.5	5	1	0.5	10	1	0.5	10
	2	0.4	2	1	2	0.2	2	2	0.2	4	2	0.2	4
	1	0.2	1	0.5	1	0.1	1	1	0.1	2	1	0.1	2

Measuring range [kPa]	Single-piston measuring ranges				Dual-piston measuring ranges								
	100 ... 12,000		200 ... 30,000		100 ... 70,000			100 ... 120,000			100 ... 140,000		
	Quantity	Nominal pressure per piece	Quantity	Nominal pressure per piece	Quantity	Nominal pressure per piece	Nominal pressure per piece	Quantity	Nominal pressure per piece	Nominal pressure per piece	Quantity	Nominal pressure per piece	Nominal pressure per piece
	[kPa]		[kPa]		[kPa]	[kPa]		[kPa]	[kPa]		[kPa]	[kPa]	
Piston and make-up weight	1	100	1	200	1	100	1,000	1	100	2,000	1	100	2,000
Standard mass set	4	2,000	4	5,000	5	1,000	10,000	4	1,000	20,000	5	1,000	20,000
	1	1,800	1	4,500	1	900	9,000	1	900	18,000	1	900	18,000
	1	1,000	1	2,500	1	500	5,000	1	500	10,000	1	500	10,000
	2	400	2	1,000	2	200	2,000	2	200	4,000	2	200	4,000
	1	200	1	500	1	100	1,000	1	100	2,000	1	100	2,000
	2	100	1	300	1	50	500	1	50	1,000	1	50	1,000
	1	50	1	250									
Fine increment weights (optional)	1	40	2	100	2	20	200	2	20	400	2	20	400
	1	20	1	50	1	10	100	1	10	200	1	10	200
	1	10	1	25	1	5	50	1	5	100	1	5	100
	2	4	2	10	2	2	20	2	2	40	2	2	40
	1	2	1	5	1	1	10	1	1	20	1	1	20

Scope of delivery

- Base with dust protection cover
- Priming pump
- Spindle pump for pressure generation and fine adjustment
- Piston connection with G ¾ male thread
- Quick connector for test items with G ½ female threaded insert, changeable
- Piston-cylinder system
- Standard mass sets in carrying case
- Set of masses manufactured to standard gravity (9.80665 m/s²)
- VG22 mineral oil (1.0 litre)
- Operating instructions in German and English language
- Factory calibration certificate

Options

- Other pressure transmission media
- Piston connection with ConTect quick-release connector
- System with increased accuracy to 0.006 %
- Other pressure units
- Set of masses manufactured to local gravity
- Fine increment weights
- Storage case for the base and the piston-cylinder system
- DKD/DAkKS or UKAS calibration certificate

Specifications

Model CPB5800

Model CPS5800 piston-cylinder systems

Version		Single-piston measuring ranges		Dual-piston measuring ranges		
Measuring range ¹⁾	bar, kg/cm ²	1 ... 120	2 ... 300	1 ... 60 / 10 ... 700	1 ... 60 / 20 ... 1,200	1 ... 60 / 20 ... 1,400
Required masses	kg	49.7	49.6	57.4	49.2	57.4
Smallest step ²⁾ (Standard mass sets)	bar, kg/cm ²	0.5	2.5	0.5 / 5.0	0.5 / 10	0.5 / 10
Smallest step ³⁾ (fine increment weights)	bar, kg/cm ²	0.02	0.05	0.01 / 0.1	0.01 / 0.2	0.01 / 0.2
Nominal cross-sectional area of the piston	cm ²	0.4032	0.1613	0.8065 / 0.0807	0.8065 / 0.0403	0.8065 / 0.0403
Measuring range ¹⁾	psi, lb/in ²	10 ... 1,600	30 ... 4,000	10 ... 800 / 100 ... 10,000	10 ... 800 / 200 ... 16,000	10 ... 800 / 200 ... 20,000
Required masses	kg	45.5	45.3	56.4	45	56.4
Smallest step ²⁾ (Standard mass sets)	psi, lb/in ²	5	20	5 / 50	5 / 100	5 / 100
Smallest step ³⁾ (fine increment weights)	psi, lb/in ²	0.2	0.5	0.1 / 1	0.1 / 2	0.1 / 2
Nominal cross-sectional area of the piston	cm ²	0.4032	0.1613	0.8065 / 0.0807	0.8065 / 0.0403	0.8065 / 0.0403
Measuring range ¹⁾	kPa	100 ... 12,000	200 ... 30,000	100 ... 6,000 / 1,000 ... 70,000	100 ... 6,000 / 2,000 ... 120,000	100 ... 6,000 / 2,000 ... 140,000
Required masses	kg	49.7	49.6	57.4	49.2	57.4
Smallest step ²⁾ (Standard mass sets)	kPa	50	250	50 / 500	50 / 1,000	50 / 1,000
Smallest step ³⁾ (fine increment weights)	kPa	2	5	1 / 10	1 / 20	1 / 20
Nominal cross-sectional area of the piston	cm ²	0.4032	0.1613	0.8065 / 0.0807	0.8065 / 0.0403	0.8065 / 0.0403
Accuracies						
Standard ^{4) 5)}	% of measured value	0.015	0.015	0.015	0.015	0.025
Premium ^{4) 5)}	% of measured value	0.007	0.006	0.006	0.007	0.007
Pressure transmission medium						
Standard		Hydraulic fluid based on VG22 mineral oil				
Optional		Sebacate oil Brake fluid Skydrol Fomblin oil	Sebacate oil Brake fluid Skydrol Fomblin oil	Sebacate oil Brake fluid Skydrol Fomblin oil	Sebacate oil Brake fluid Skydrol Fomblin oil	Sebacate oil
Material						
Piston		Steel	Steel	Tungsten carbide / steel	Tungsten carbide / steel	Tungsten carbide / steel
Cylinder		Bronze	Steel	Steel / tungsten carbide	Steel / tungsten carbide	Steel / tungsten carbide
Mass set		Stainless steel, non-magnetic				
Weight						
Piston-cylinder system	kg	1	0.8	2	2	2
Storage case for piston-cylinder system	kg	3.1				
BAR standard mass sets (in 2 wooden cases)	kg	61.3	61.2	69	60.8	69
PSI standard mass sets (in 2 wooden cases)	kg	57.1	56.9	68	56.6	68
BAR fine increment weights	kg	0.33	0.5	0.5	0.5	0.5
PSI fine increment weights	kg	0.23	0.34	0.34	0.34	0.34
Dimensions						
Carrying case for standard mass sets		400 x 310 x 310 mm (W x H x D)				
Storage case for piston-cylinder systems (optional)		300 x 265 x 205 mm (W x H x D)				

- Theoretical starting value; corresponds to the pressure value generated by the piston or the piston and its make-up weights (by their own weight). To optimise the operating characteristics more weights should be loaded.
- The smallest pressure change value that can be achieved based on the standard weight set. To reduce this, a set of trim masses is also available.
- The smallest pressure change value that can be achieved based on the optional fine increment weights. For further reductions, an accessory of class M1 or F1 trim masses is available.
- The accuracy from 10 % of the measuring range is based on the measured value. In the lower range, a fixed error based on 10 % of the range applies.
- Measurement uncertainty assuming reference conditions (ambient temperature 20 °C, air pressure 1013 mbar, relative humidity 40 %). For operation without a CalibratorUnit, corrections must be made if required.

Model CPB5800 base

Base version

Hydraulic standard	up to a max. 1,200 bar / 16,000 psi; with internal pressure generation
Hydraulic high-pressure	up to a max. 1,400 bar / 20,000 psi; with internal pressure generation

Pressure transmission medium

Standard	Hydraulic fluid based on VG22 mineral oil
Optional	Sebacate oil, brake fluid, Skydrol or Fomblin oil (dependant upon measuring range)
Oil reservoir	250 cm ³

Connections

Connection for piston-cylinder system	G ¾ male / optional: ConTect quick-release connector (not for 1,400 bar version)
Test item connector	G ½ B female quick connector as standard, freely rotating, changeable (for other threaded inserts, see accessories)

Material

Piping in instrument base	1.4404 stainless steel, 6 x 2 mm
---------------------------	----------------------------------

Weight

Standard hydraulic base	18.0 kg / 19.0 kg (incl. optional ConTect quick-release connector)
Hydraulic high-pressure base	18.0 kg
Storage case for the base	8.5 kg

Permissible ambient conditions

Operating temperature	18 ... 28 °C
-----------------------	--------------

Dimensions

Base	400 x 375 x 265 mm (W x D x H), for details, see technical drawings
------	---

Approvals and certificates

CE conformity

Pressure equipment directive	97/23/EC (Module A)
------------------------------	---------------------

Certificate

Calibration	3.1 calibration certificate Option: DKD/DAkS calibration certificate or UKAS calibration certificate
-------------	---

Transport dimensions for complete instrument

The complete instrument, in its standard version and standard scope of delivery, consists of 3 packages on a single pallet. The dimensions are 1,200 x 800 x 500 mm.

The overall weight is dependant on the measuring range

Version in bar	Weight in kg	
	net	gross
Single-piston measuring ranges		
1 ... 120 bar	81.5	100
2 ... 300 bar	81.5	100
Dual-piston measuring ranges		
1 ... 60 bar / 10 ... 700 bar	90	108.5
1 ... 60 bar / 20 ... 1.200 bar	82	100.5
1 ... 60 bar / 20 ... 1.400 bar	90	108.5

Version in psi	Weight in kg	
	net	gross
Single-piston measuring ranges		
10 ... 1.600 psi	77.5	96
30 ... 4.000 psi	77	95.5
Dual-piston measuring ranges		
10 ... 800 psi / 100 ... 10.000 psi	89	107.5
10 ... 800 psi / 200 ... 16.000 psi	77.5	96
10 ... 800 psi / 200 ... 20.000 psi	89	107.5

Dimensions in mm

The picture shows a 1,200 bar version of the CPB5800 instrument base with the ConTect quick-release connector option. The 1,400 bar high-pressure version does not differ from it dimensionally, only in the arrangement of the control elements.

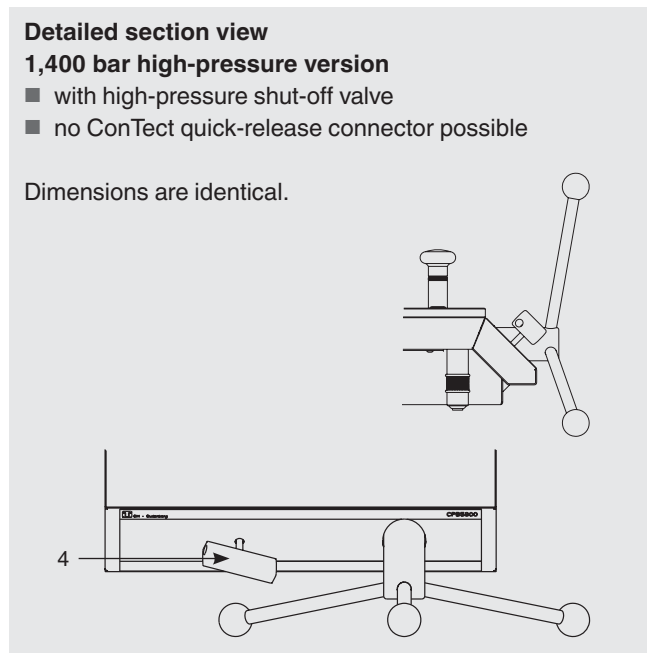
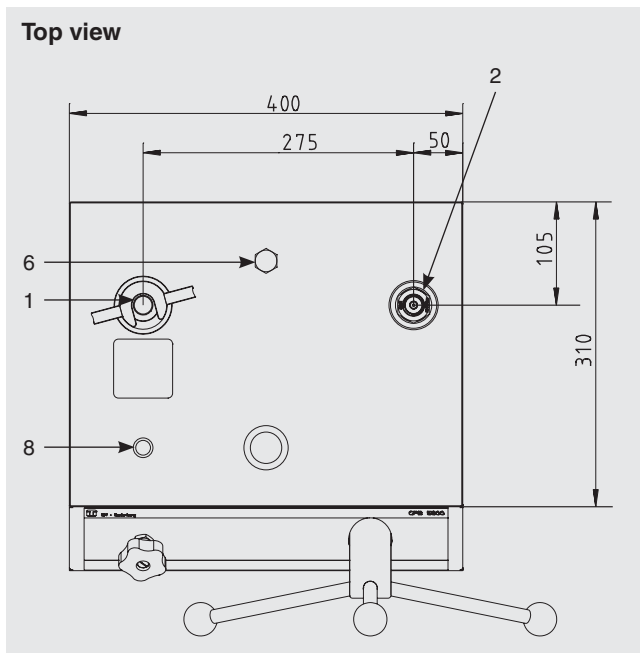
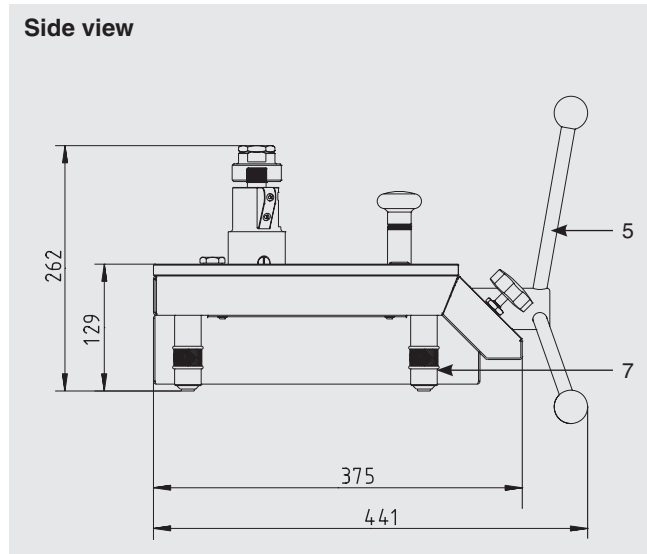
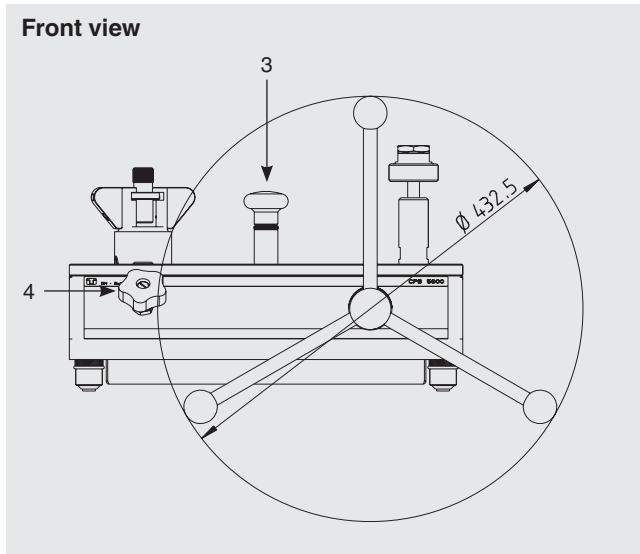

- (1) Connector for piston-cylinder system
- (2) Test item connection
- (3) Priming pump
- (4) Outlet valve
- (5) Spindle pump with star handle, removable
- (6) Oil reservoir sealing screw
- (7) Rotatable feet
- (8) Level

Further pressure balances within our calibration technology programme

Pressure balance, model CPB3800

Measuring ranges:

- Hydraulic 1 ... 120 up to 10 ... 1,200 bar or 10 ... 1,600 up to 100 ... 16,000 psi, respectively

Accuracy: 0.05 % of measured value
0.025 % of measured value (optional)

For specifications see data sheet CT 31.06



Model CPB3800 pressure balance

Pressure balance, model CPB5000

Measuring ranges:

- Pneumatic -0.03 ... -1 up to +0.4 ... +100 bar or -0.435 ... -14 up to +5.8 ... +1,500 psi, respectively

Accuracy: 0.015 % of measured value
0.008 % of measured value (optional)

For specifications see data sheet CT 31.01



Pressure balance, model CPB5000

Pressure balance for high pressure, model CPB5000HP

Measuring ranges:

- Hydraulic 25 ... 2,500, 25 ... 4,000 or 25 ... 5,000 bar, or 350 ... 40,000, 350 ... 60,000 or 350 ... 70,000 psi, respectively
- 50 / 2,600 bar dual piston or
600 / 40,000 psi dual piston, respectively

Accuracy: 0.025 % of measured value
0.02 % of measured value (optional)

For specifications see data sheet CT 31.51



Pressure balance for high pressure, model CPB5000HP

Pressure balance for differential pressure, model CPB5600DP

Measuring range = (static pressure + differential pressure):

- Pneumatic 0.03 ... 2 up to 0,4 ... 100 bar or 0.435 ... 30 up to 5.8 ... 1,500 psi, respectively
- Hydraulic 0.2 ... 60 up to 25 ... 1,600 bar or 2.9 ... 1,000 up to 350 ... 23,200 psi, respectively

Accuracy: 0.015 % of measured value
0.008 % of measured value (optional)

For specifications see data sheet CT 31.56



Pressure balance for differential pressure, model CPB5600DP

Accessories

Trim-mass sets M1 and F1

The weights included in the CPM5800 standard mass set or fine increment weights are ideally suited for everyday use. If smaller intermediate values need to be generated, we recommend using a set of class M1 or F1 trim masses, with the following weights:

1 x 50 g, 2 x 20 g, 1 x 10 g, 1 x 5 g, 2 x 2 g, 1 x 1 g,
1 x 500 mg, 2 x 200 mg, 1 x 100 mg, 1 x 50 mg, 2 x 20 mg,
1 x 10 mg, 1 x 5 mg, 2 x 2 mg, 1 x 1 mg



Set of trim masses

Set of adapters for quick connector

As a standard, the pressure balance is equipped with a quick connector for connecting the test item. For this purpose, various threaded adapters, which can be easily changed, are available:

- Adapter set: G ¼, G ⅜, ½ NPT, ¾ NPT and M20 x 1.5
- Adapter set NPT: ⅛ NPT, ¼ NPT, ⅜ NPT and ½ NPT

Additionally the sets of adapters include spare O-rings as well as a spanner with SW32 flats and SW14 flats, for changing the adapters.

Other threaded inserts are available on request.



Set of adapters

Separator

The separators have been specifically designed for measuring instruments, which should not come into contact with the medium of the pressure balance or to protect against contamination of the pressure balance from the test items.



Fig. left: Separator (without diaphragm)
Fig. middle: Separator (with diaphragm) 700 bar
Fig. right: Separator (with diaphragm) 1,200 bar

Designation/Variant	Order no.
Set of trim masses (1 mg up to 50 g), class F1	7093874
Set of trim masses (1 mg up to 50 g), class M1	14025325
Set of adapters for quick connector in case with G ¼, G ⅜, ½ NPT, ¾ NPT and M20 x 1.5 threaded inserts for insertion in the knurled nut on the test item connector	2036941
Set of "NPT" adapters for quick connector in case with ⅛ NPT, ¼ NPT, ⅜ NPT and ½ NPT threaded inserts for insertion in the knurled nut on the test item connector	12563626
90° angle connection, for test items with back mounting connection	1564838
Separator (without diaphragm), max. 1,000 bar	1565389
Separator (to separate two liquid media by a diaphragm), max. 700 bar	14031253
Separator (to separate two liquid media by a diaphragm), max. 1,200 bar	14031254
O-ring set consisting of 5 pcs. 8 x 2 and 5 pcs. 4 x 2.2	12328562
Operating fluid for CPB series up to a max. 4,000 bar, 1 litre	2099882
Adapter for mounting model CPS5800 hydraulic piston-cylinder systems into a ConTect system mechanism	14031252
Test item connecting piece, G 3/4 female to G 1/2 female, free-rotating, operation as a comparison test pump is possible	14031251
Special test-item adapter with quick connect, for the matching to the ConTect system mechanism, operation as a comparison test pump is possible	2152634
Electrical piston drive unit for 700 bar, 1,200 bar and 1,400 bar measuring ranges (AC 230 V/50 Hz)	14031260

Model CPU5000 CalibratorUnit

The CPU5000 CalibratorUnit is a compact tool for use with a pressure balance. In particular when highly-accurate measuring values, with measurement uncertainties of less than 0.025 %, are required, complicated mathematical calculations and corrections are necessary. With the CPU5000, all critical ambient parameters can be registered and automatically corrected.

CPU5000 basic package

The basic CalibratorUnit package converts masses into the corresponding pressure value, or vice versa, it calculates the masses required for a specific pressure value with consideration to the local gravity, for location-independent measurements. The conversion can be carried out in all common pressure units. The input of all parameters takes place manually.

Sensor package

The "sensor package" extension includes sensors to automatically register all critical parameters such as room temperature, air pressure, relative humidity and piston temperature and to update calculations continually.

Multimeter package

Furthermore, with the multimeter package, a calibrator function for pressure transmitters can be integrated. With this, the sensor to be tested, without additional power can be supplied with a DC 24 V voltage and the output signal (V, mA) can be measured. Besides the signal, the automatically converted pressure value is also shown on the display.

Piston position display

With the extension for "piston position indication", the piston position can be measured (contact free) and shown on the CalibratorUnit with high resolution (not available for dual-range piston-cylinder systems).

Further specifications on the CPU5000 CalibratorUnit can be found in data sheet CT 35.01.



Model CPB5800 pressure balance with model CPU5000 CalibratorUnit

Order variants

CPU5000 base packet (processor only)

- Calculation of the mass loads
- Manual input of all parameters

Sensor package for measuring of:

- Ambient temperature
- Atmospheric pressure
- Humidity
- Cylinder temperature

Multimeter package

- Voltage supply, DC 24 V
- Measurement of output signal (V, mA) incl. conversion into pressure values

Piston position display

- Contact-free measuring of piston position

Ordering information

Instrument base

CPB5800 / Pressure medium / Version / Connection of piston-cylinder system / Piston-cylinder system / Mass set / Storage box / Additional order details

Piston-cylinder system

CPS5800 / Accuracy / Gravity value g / Measuring range / Connection for piston-cylinder system / Carrying case for piston-cylinder system / Calibration for piston-cylinder system / Additional order details

Mass set

CPM5800 / Pressure unit / Gravity value g / Standard mass set / Fine increment weights / Calibration for standard mass set / Calibration for fine increment weights / Additional order details

© 2012 WIKA Alexander Wiegand SE & Co. KG, all rights reserved.
The specifications given in this document represent the state of engineering at the time of publishing.
We reserve the right to make modifications to the specifications and materials.

