

Measuring insert for process thermocouple Model TC12-A

WIKA data sheet TE 65.16



for further approvals
see page 5

Applications

- Replacement measuring insert for servicing

Special features

- Application ranges from 0 ... 1,200 °C
- Made of mineral-insulated sheathed cable
- Explosion-protected versions



Measuring insert for process thermocouple,
model TC12-A

Description

The measuring inserts described here are intended for installation in model TC12-B or TC12-M process resistance thermometers (see figures at right). Operation without thermowell is appropriate only in special cases.

The measuring insert is made of flexible, mineral-insulated sheathed cable. The sensor is located in the tip of the measuring insert.

Type of sensor, number of sensors and accuracy can each be selected to suit the respective application.







Model TC12-B



Model TC12-M

Explosion protection

Explosion protection	Ignition protection type	Zone
ATEX 	Ex i	Zone 1, gas [2G Ex ia ... Gb] Zone 1 mounting to zone 0, gas [1/2G Ex ia ... Ga/Gb] ²⁾
ATEX 	Ex d ¹⁾	Zone 1, gas [2G Ex d ... Gb] Zone 1 mounting to zone 0, gas [1/2G Ex d ... Ga/Gb] ²⁾
IECEX (in conjunction with ATEX) 	Ex i	Zone 1, gas [2G Ex ia ... Gb] Zone 1 mounting to zone 0, gas [1/2G Ex ia ... Ga/Gb] ²⁾
IECEX (in conjunction with ATEX) 	Ex d ¹⁾	Zone 1, gas [2G Ex d ... Gb] Zone 1 mounting to zone 0, gas [1/2G Ex d ... Ga/Gb] ²⁾

1) Only if the model TC12-A is built into the neck tube (models TC12-B, TC12-M)

2) Only with the use of a thermowell

The classification/suitability of the instrument (permissible power P_{max} as well as the permissible ambient temperature) for the respective category can be seen on the EC-type examination certificate, the IECEx certificate or in the operating instructions.

Attention:

Built into a model TC12-B process thermocouple - depending on the application - a measuring insert can be used with “intrinsically-safe Ex i” or “flameproof enclosure Ex d” ignition protection type. One such measuring insert, suitable for Ex d, is marked Ex i.

The use of a model TC12-A measuring insert in hazardous areas, without a suitable protective housing, is not permitted!



Example: Model TC12-B

Sensor

Sensor types

Model	Recommended max. operating temperature
K (NiCr-Ni)	1,200 °C
J (Fe-CuNi)	800 °C
N (NiCrSi-NiSi)	1,200 °C
E (NiCr-CuNi)	800 °C

Thermocouple Model	Class	
	DIN EN 60584 part 2	ISA MC96.1
K	1 and 2	Standard, special
J	1 and 2	Standard, special
N	1 and 2	-
E	1 and 2	-

Measuring point

- Welded insulated (ungrounded)
- Welded at the bottom (grounded)

Tolerance value

For the tolerance value of thermocouples, a cold junction temperature of 0 °C has been taken as the basis.

For detailed specifications for thermocouples, see Technical Information IN 00.23 at www.wika.com.

Listed models are available both as single or dual thermocouples. The thermocouple will be delivered with an insulated measuring point, unless explicitly specified otherwise.

The actual application range of these thermometers is limited both by the permissible maximum temperature of the thermocouple and the sheath material as well as by the permissible maximum temperature of the thermowell material.

Electrical connection

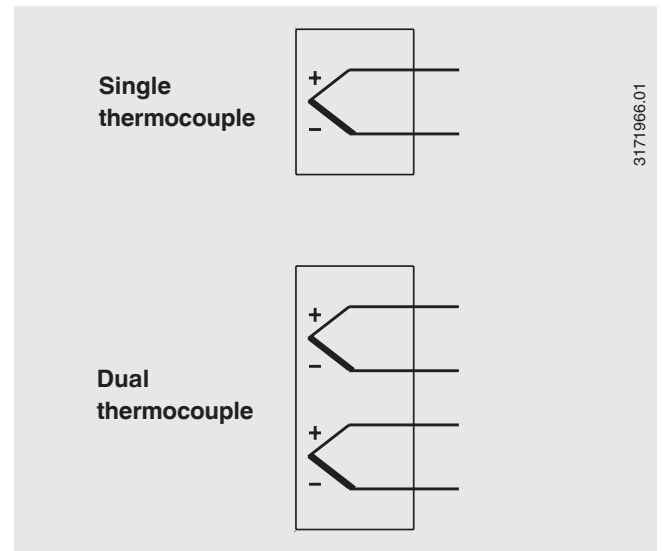

Colour code of cable strands

Sensor type	Standard	Positive	Negative
K	DIN EN 60584	green	white
J	DIN EN 60584	black	white
E	DIN EN 60584	violet	white
N	DIN EN 60584	pink	white

Dimensions in mm

The replaceable measuring insert is made of a vibration-resistant, sheathed, mineral-insulated cable (MI cable).
Material of MI cable: Ni alloy 2.4816 (Inconel 600), others on request

Dimensions	
Measuring insert length l_5	≥ 300 mm
Measuring insert diameter $\varnothing d$	
Standard:	3 mm 4.5 mm 6 mm 8 mm
Option (on request):	1/8 inch (3.17 mm) 1/4 inch (6.35 mm) 3/8 inch (9.53 mm)

The diameter of the measuring insert should be approx. 1 mm smaller than the bore diameter of the thermowell.

Gaps of more than 0.5 mm between thermowell and the measuring insert will have a negative effect on the heat transfer, and they will result in unfavourable response behaviour from the thermometer.

When fitting the measuring insert into a thermowell, it is very important to determine the correct insertion length (= thermowell length for bottom thicknesses of ≤ 5.5 mm). In order to ensure that the measuring insert is firmly pressed down onto the bottom of the thermowell, the insert must be spring-loaded (spring travel: max 20 mm).

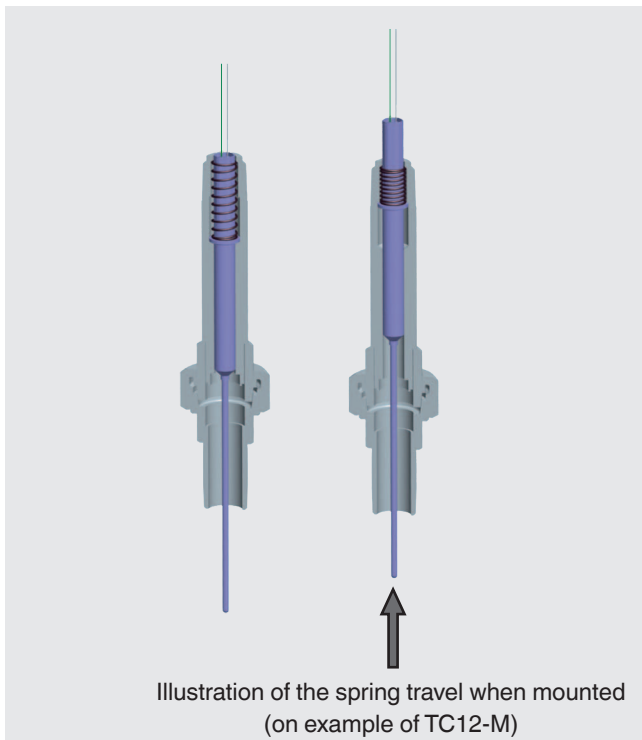

Attention:

The use of a model TC12-A measuring insert is only ever allowed with a model TC12-B or TC12-M thermocouple!

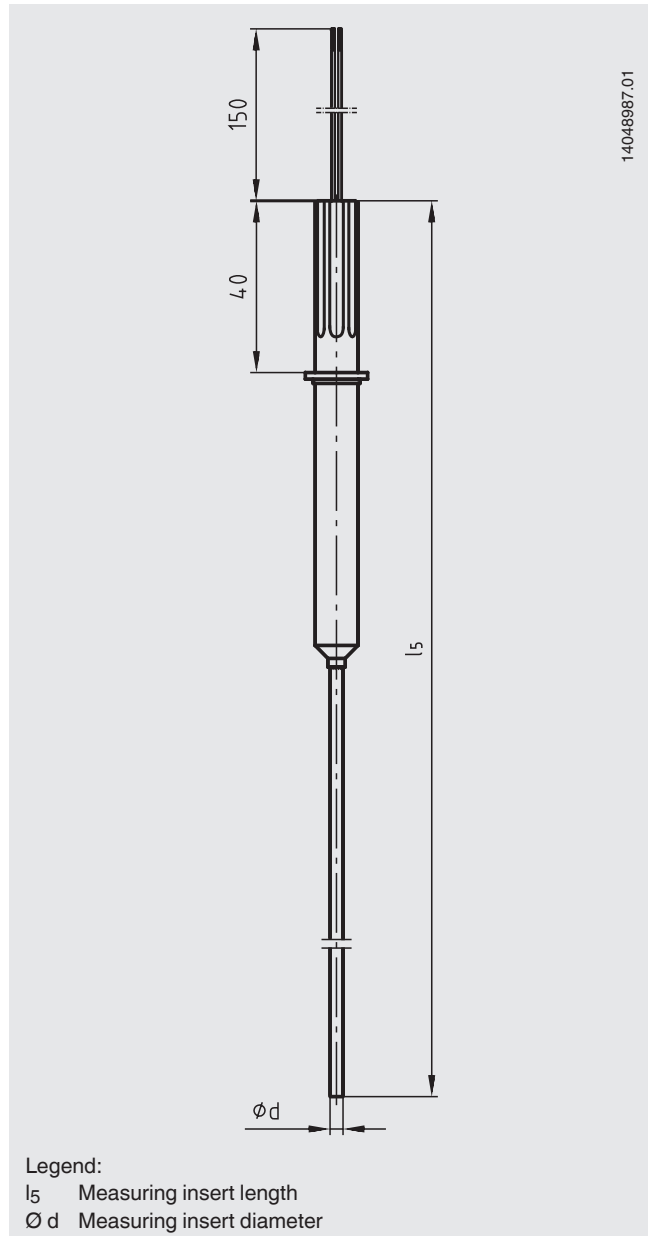

14048987.01

Operating conditions

Vibration resistance

50 g, peak-to-peak

Response time (in water)

$t_{50} < 5 \text{ s}$

$t_{90} < 10 \text{ s}$

Specifications for measuring insert diameter 6 mm:
The thermowell required for operation increases the response time dependent upon the actual parameters for the thermowell and the process.

Ambient and storage temperature

{-50} -40 ... +80 °C

{ } Items in curved brackets are available optional extras

Ingress protection

IP 65 per IEC 529/EN 60529

The measuring inserts for the model TC12-A are designed for mounting into a model TC12-B thermocouple.

These thermocouples feature connection housings/cable glands/protective fittings which ensure a high IP protection (see data sheet TE 65.17).

CE conformity

EMC directive ¹⁾

2004/108/EC, EN 61326 emission (group 1, class B) and interference immunity (industrial application)

ATEX directive (option)

94/9/EC, EN 60079-0, EN 60079-11, EN 60079-1 ²⁾

Approvals (option)

- **IECEX**, international certification for the Ex area
- **GOST-R**, import certificate, Russia
- **GOST**, metrology/measurement technology, ignition protection type "i" - intrinsic safety, Russia
- **KOSHA**, ignition protection type "i" - intrinsic safety, South Korea
- **PESO (CCOE)**, ignition protection type "i" - intrinsic safety, ignition protection type "d" - flameproof enclosure, India ²⁾

Certificates (option)

Certification type	Measuring accuracy	Material certificate
Test procedure	x	x
2.2 test report	x	x
3.1 inspection certificate	x	-
DKD/DAkkS calibration certificate	x	-

The different certifications can be combined with each other.

¹⁾ Only for built-in transmitter

²⁾ Only with mounting of model TC12-A in a neck tube (models TC12-B and TC12-M)

Approvals and certificates, see website

Ordering information

Model / Explosion protection / Ignition protection type / Zone / Sensor / Sensor specification / Application range of the thermometer / Insertion length / Measuring insert diameter Ø d / Sheath material / Mechanical requirements / Certificates / Options

© 2013 WIKA Alexander Wiegand SE & Co. KG, all rights reserved.
The specifications given in this document represent the state of engineering at the time of publishing.
We reserve the right to make modifications to the specifications and materials.

