

Model CFS25 Coriolis Flowtubes

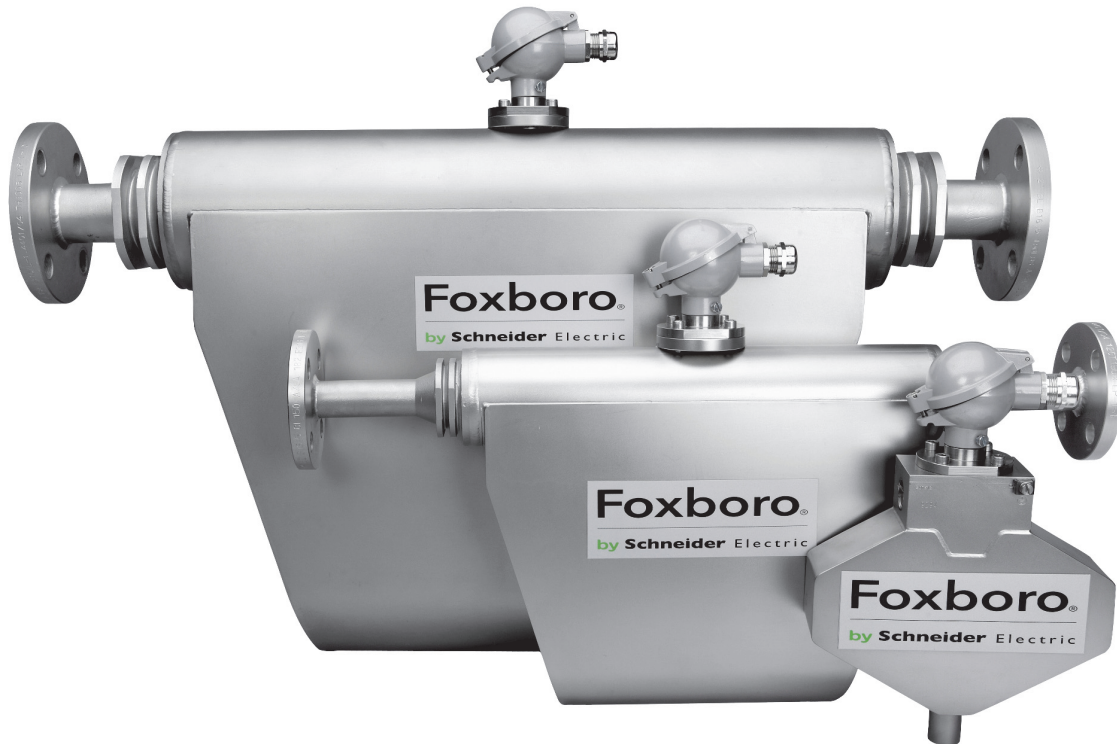

Foxboro[®] brand CFS25 Coriolis flowtubes combine with a Model CFT51 Digital Coriolis Mass Flow Transmitter to form an I/A Series[®] Coriolis Mass Flow and Density Meter. The principle of Coriolis acceleration is used, which allows true mass flow rate measurements of fluids to be made directly without the need for external temperature, pressure, or specific gravity measurements.

FEATURES

- ▶ Economical design is ideally suited for typical applications in the chemical industry.
- ▶ Precision system achieved using digital signal processing (DSP) transmitter.
- ▶ High system accuracy: $\pm 0.10\%$ of flow rate plus flowtube zero instability for liquid; and $\pm 0.50\%$ of flowrate plus flowtube zero instability for gas.
- ▶ Density accuracy of ± 0.0005 g/cc⁽¹⁾ or better.
- ▶ Wide rangeability in excess of 100:1 without sacrificing performance.
- ▶ All flowtubes are available with a dual-path design (parallel loops). Smaller flowtubes are also available with a single-path design (serial loops) ideal for shear-sensitive fluids and applications requiring positive cleaning.
- ▶ Welded 304 stainless steel enclosure.
- ▶ Nickel alloy (equivalent to Hastelloy[®] C-22(2)) construction available on some flowtube sizes.
- ▶ Designed for CSA, CSAus, ATEX, and IECEx hazardous area locations. Applicable agency plate also includes the CE mark.

1. With in situ calibration.

2. Hastelloy is a registered trademark of Haynes International Inc.

INTRODUCTION

This I/A Series Mass Flow and Density Meter, comprising a CFT51 Mass Flow and Density Transmitter and a CFS25 Mass Flowtube, measures fluid mass flow rate directly, not inferentially. The direct measurement of mass eliminates the inaccuracies of multiple process measurements associated with volumetric flow devices are eliminated.

This flowmeter is an advanced generation of mass flow devices using Coriolis principles. It incorporates significant improvements in transmitter and flowtube design, including digital signal processing (DSP), computer modeling, remote communications, automated manufacturing processes, construction and testing that all add up to an ideal product for today and tomorrow's "real world" process fluid flow applications.

MODEL CFT51 DSP TRANSMITTER

The CFS25 Mass Flowtube is used with the Model CFT51 Digital Coriolis Mass Flow Transmitter to form a mass flow and density meter. The transmitter uses DSP techniques to improve flowmeter performance and to minimize the shortcomings experienced by existing Coriolis flowmeters, such as operation during two-phase flow, partial empty tube conditions, and batching from empty. Refer to PSS 1-2B7 C for further data and specifications relating to the Model CFT51 transmitter.

PRODUCT PATENTS

This product and associated components are protected by one or more of the following US patents: 6311136, 6505519, 6507791, 6754594, 6758102, 6917887, 6950760, 6981424, 7124646, 7136761, 7146280, 7404336, 7505854, 7571062, 7784360, 8000906.

APPLICATION VERSATILITY

This brand of Coriolis flowmeter is insensitive to varying process conditions. In addition to accurately measuring liquid, it can also be used in applications with entrained air, non-Newtonian fluids, viscous and abrasive fluids, slurries, and liquefied gases.

REAL WORLD CONDITIONS

Exemplified by:

- ▶ High accuracy at realistic nominal velocities means reduced erosion
- ▶ Immunity to external pipe vibrations
- ▶ Low pressure loss
- ▶ High accuracy over a wide range of fluid densities
- ▶ Immune to entrained air
 - Continues to operate during two-phase flow
 - No zero drifting with CFT51 DSP transmitter

HIGH FLOWTUBE RELIABILITY

Assured because of:

- ▶ Advanced finite element analysis (FEA) technology for flowtube design
- ▶ Annealed process-wetted welds
- ▶ Hydrostatically tested at 1.5 times the rated maximum pressure

FLOWEXPERTPRO™

The FlowExpertPro software is primarily used to size Foxboro flowmeters. It also ensures that the user has selected the proper flowmeter type for an application.

This meter selection website is a free tool for all users, without the need for registration. In addition to flowmeter selection and sizing, FlowExpertPro includes the following features:

- ▶ Incorporates a large library of the physical properties of typical process fluids.
- ▶ Displays results in tabular or graphic format.
- ▶ Allows user to save, print, or E-mail results.

- ▶ Provides reference to applicable flowmeter PSSs and other related flowmeter documentation.
- ▶ Calculates minimum and maximum flow rates, rangeability, pressure loss, and Reynolds Number, using established flow equations.
- ▶ Allows for material and flange selection.
- ▶ Provides ANSI or metric flange recommendations for predicted flow pressure and temperature.

Visit www.FlowExpertPro.com to access this program, or contact Global Customer Support for further information and technical support.

OPERATING CONDITIONS (FLOWTUBE ONLY)

Influence	Reference Operating Conditions	Normal Operating Condition Limits	Transportation and Storage Limits
Process Temperature	Water at 23 ±8°C (73 ±13°F)	Per Temperature Range selection in Model Code	Not Applicable
Process Pressure	Water at 100 to 500 kPa (15 to 75 psi)	See Table 2	Not Applicable
Ambient Temperature (a) (b) (c)	23 ±2°C (73 ±3°F)	-40 and +70°C (-40 and +158°F)	-40 and +100°C (-40 and +212°F)
Relative Humidity	50 ±10%	5 and 100% (d)	0 and 100% Noncondensing

- a. Where lagging or heat tracing of flowtube is involved, the case temperature may exceed these limits.
- b. PVC insulated cable is suitable for ambient temperatures from -20 to +80°C (-4 to +176°F). FEP insulated cable is suitable for ambient temperatures from -40 to +85°C (-40 to +185°F).
- c. Refer to Table 3 for restrictions in ambient temperature with certain electrical certifications.
- d. 100% relative humidity value includes condensation.

SYSTEM PERFORMANCE SPECIFICATIONS

The following system performance specifications are for Reference Operating Conditions unless otherwise specified. Refer to PSS 1-2B7 C for Model CFT51 Digital Coriolis Mass Flow Transmitter specifications.

Accuracy - Mass Flow Rate for Liquids (Includes Linearity, Hysteresis, and Repeatability)

±0.10% + Zero Instability

Accuracy in % of rate is, therefore,

$$\text{Accuracy} = \pm 0.10\% + \left(\frac{\text{Zero Instability}}{\text{Mass Flow Rate}} \times 100 \right) \%$$

For example, for a CFS-3100 flowtube, the measured Mass Flow Rate value of a liquid is 50 lb/min; then from Table 1, Zero Instability for a CFS-3100 flowtube is 0.0114 lb/min; and therefore the accuracy in % of Rate, using the liquid equation, is:

$$\pm 0.10\% + \left(\frac{0.0114 \text{ lb/min}}{50 \text{ lb/min}} \times 100 \right) \% = \pm 0.1228\%$$

Therefore, the accuracy of the measured liquid is ±0.1228% of the measured mass flow rate value of 50 lb/min, or:

$$\pm 0.1228\% \times (50 \text{ lb/min}) = \pm 0.0614 \text{ lb/min}$$

Accuracy - Mass Flow Rate for Gases (Includes Linearity, Hysteresis, and Repeatability)

±0.50% + Zero Instability

Accuracy in % of rate is, therefore,

$$\text{Accuracy} = \pm 0.50\% + \left(\frac{\text{Zero Instability}}{\text{Mass Flow Rate}} \times 100 \right) \%$$

Table 1. Zero Instability (a)

Model CFS25	Zero Instability	
	kg/hr	lb/min
-0325	0.033	0.0012
-0650	0.065	0.0024
-1550	0.155	0.0057
-3100	0.310	0.0114
-5500	0.550	0.0202
-7900	0.790	0.0291
-028K	2.800	0.1029
-065K	6.500	0.2388

a. In the accuracy equation, Zero Instability and Mass Flow Rate units must be the same.

Accuracy – Process Temperature

- ▶ ±1°C (±1.8°F) ± 0.5% of reading
- ▶ Repeatability ±0.1%
- ▶ Requires platinum RTD for temperatures -40°C (-40°F) and below

Accuracy – Density for Liquids

±0.0005 g/cc ⁽³⁾

3. With in situ calibration.

FUNCTIONAL SPECIFICATIONS

Mass Flow Rate Ranges

Nominal flow rate defined as 1 bar pressure drop for water at 20°C.

Model CFS25	Minimum		Maximum		Nominal	
	kg/h	lb/min	kg/h	lb/min	kg/h	lb/min
-0325	3	0.11	300	11	150	5.5
-0650	6	0.22	600	22	300	11
-1550	15	0.55	1,500	55	750	27.5
-3100	30	1.1	3,000	110	1,500	55
-5500	55	2.0	5,500	203	2,750	101.5
-7900	79	2.9	7,900	291	3,950	145.5
-028K	280	10	28,000	1,030	14,000	515
-065K	650	24	65,000	2,390	32,500	1,195

Process Pressure Limits

Table 2. Flowtube Process Pressure Rating (a)

Model CFS25	Maximum Working Pressure (MWP)	
	bar	psi
-0325	200	2,900
-0650	200	2,900
-1550	200	2,900
-3100	200	2,900
-5500	345	5,000
-7900	100	1,450
-028K	100	1,450
-065K	100	1,450

a. Pressure ratings are for flowtubes only. End connections may limit the pressure rating.

Pressure Loss - FlowExpertPro.com

To determine pressure loss or sizing for your application, merely have your process information available and visit the FlowExpertPro.com web site.

Vibration Stability

Vibration stability has been validated per IEC 61298-3 for up to 10 m/s² (1 g) at 5 to 500 Hz.

Process Liquid Density

For liquids, process fluid density ranges from 200 to 3000 kg/m³ (12.5 to 187 lb/ft³); or a specific gravity range of 0.2 to 3.0. Note that a specific gravity of 1 corresponds to a fluid density of 1000 kg/m³ (62.4 lb/ft³).

PHYSICAL SPECIFICATIONS

Flowtube to Transmitter Interface

The flowtube has a terminal for the local earth (ground) connection. For signal connections, the flowtube is provided with an integrally mounted electrical junction box that meets the weatherproof rating of IP65 as defined by IEC 60529, and provides the environmental and corrosion resistance rating of NEMA Type 4X. T

he junction box contains a pair of five-position feedthrough type terminal blocks. The terminal blocks are connected to the flowtube through a hermetic seal with properly spaced, intrinsically safe wiring. An internally threaded 1/2 NPT conduit fitting is provided at the junction box for signal cabling.

Interconnecting cable to the transmitter is not provided with the tube. However, FEP or PVC jacketed cable can be ordered separately for this purpose. Refer to “ACCESSORIES – CABLES” for specifications and ordering instructions.

Heating Jacket Option

Contact Global Customer Support for availability of the Heating Jacket (option -A) for your selected flowtube.

Flowtube Enclosure

AISI Type 304 stainless steel (304ss) with a matte finish. Seams are welded and the enclosure is free from water and dust-retaining cavities.

Ingress Protection

Hermetically sealed, welded flowtube enclosure provides ingress protection at internal pressure less than atmospheric pressure.

Flowtube Mounting

Designed for either horizontal or vertical mounting.

Dimensions

Refer to “DIMENSIONS – NOMINAL” on page 11.

Approximate Mass

Model CFS25	Flange Size	With ANSI B16.5 Flange Pressure Class (a)			
		150	300	600	900
-0325 or -0650, 316L ss	0.5 inch	8.0 kg (17.7 lb)	8.9 kg (19.7 lb)		12.6 kg (27.7 lb)
-1550 or -3100, 316L ss		11.7 kg (25.8 lb)	12.6 kg (27.8 lb)		16.2 kg (35.8 lb)
-5500, 316L ss	1 inch	6.7 kg (14.7 lb)	7.6 kg (16.7 lb)	8.5 kg (18.7 lb)	Not Available
-7900, 316L ss		6.4 kg (14.2 lb)	7.3 kg (16.2 lb)	8.3 kg (18.2 lb)	
-028K, 316L ss		10.3 kg (22.7 lb)	11.2 kg (24.7 lb)	12.1 kg (26.7 lb)	
-028K, Nickel alloy (b)		Contact Global Customer Support			
-065K, 316L ss	3 inch	36.5 kg (80.4 lb)	40.1 kg (88.4 lb)	42.8 kg (94.4 lb)	

a. Includes flowtube with Temperature Range option S (Standard), junction box, slip-on flanges, and related fittings (if applicable). See Model Code for other end connections.

b. Equivalent to Hastelloy® C-22.

ELECTRICAL SAFETY SPECIFICATIONS

These flowtubes meet the electrical safety descriptions listed in the table below. For detailed information or status of approvals or certifications, contact Global Customer Support.

Refer to the transmitter instruction for transmitter electrical safety specification information.

Table 3. Electrical Safety Specification When Used with CFT51

Testing Laboratory, Type of Protection, and Area Classification	Application Conditions (a)	Electrical Safety Design Code
CSA/CSAus Intrinsically Safe Class I, Division 1/Zone 0, Groups C, D	Temperature Class T4 Ta = -40°C to +70°C Connected to CFT51 Electrical Safety Code CDA or CNA	CAA
ATEX Intrinsically Safe Ex ia/ic, Group IIB	Temperature Class T4 Ta = -40°C to +70°C Connected to CFT51 Electrical Safety Code ADA or ANA	AAA
IECEX Intrinsically Safe Ex ia/ic, Group IIB	Temperature Class T4 Ta = -40°C to +70°C Connected to CFT51 Electrical Safety Code EDA or ENA	EAA
No electrical certification		YYY

a. Process temperature range is -100°C to +70°C.

MODEL CODE – CFS25 SERIES MASS FLOWTUBES

Description	Model
CFS25 Series Mass Flowtube (not supplied with cable to transmitter) (a)	CFS25
Nominal Capacity	
325 kg/hr (12 lbs/min) serial flow nominal size 1/8 in (3 mm)	-0325
650 kg/hr (24 lbs/min) parallel flow nominal size 1/8 in (3 mm)	-0650
1,550 kg/hr (57 lbs/min) serial flow nominal size 1/4 in (6 mm)	-1550
3,100 kg/hr (114 lbs/min) parallel flow nominal size 1/2 in (13 mm)	-3100
5,500 kg/hr (200 lbs/min) parallel flow nominal size 1/2 in (13 mm)	-5500
7,900 kg/hr (290 lbs/min) parallel flow nominal size 3/4 in (20 mm)	-7900
28,000 kg/hr (1,028 lbs/min) parallel flow nominal size 1 in (25 mm)	-028K
65,000 kg/hr (2,390 lbs/min) parallel flow nominal size 2 in (50 mm)	-065K
Flowtube Wetted Material	
AISI Type 316L Stainless Steel (316L ss)	S
Nickel alloy comparable to Hastelloy® C-22 (with Nominal Capacity -028K only)	H
End Connections (b)	
Flanges - ANSI B16.5	
0.50 in Class 150	AA
0.50 in Class 300	AB
0.50 in Class 600	AC
0.50 in Class 900	AD
0.50 in Class 1500	BV
0.75 in Class 150	BA
0.75 in Class 300	BB
0.75 in Class 600	BC
1.00 in Class 150	AE
1.00 in Class 300	AF
1.00 in Class 600	AG
1.00 in Class 900	AH
1.50 in Class 150	AJ
1.50 in Class 300	AK
1.50 in Class 600	AL
2.00 in Class 150	AN
2.00 in Class 300	AO
2.00 in Class 600	AP
3.00 in Class 150	AS
3.00 in Class 300	AT
3.00 in Class 600	AU
Flanges - DIN EN 1092-1 Form B1 (Raised Face)	
DN25 PN40	DC
DN25 PN100	DD
DN50 PN40	DG
DN50 PN100	DH
DN80 PN40	DJ
DN80 PN100	DK

MODEL CODE – CFS25 SERIES MASS FLOWTUBES (CONTINUED)

Description	Model
Female Thread	
0.50 in BSPP	FA
1.00 in BSPP	FD
1.50 in BSPP	FF
2.00 in BSPP	FH
0.50 in NPT	FK
1.00 in NPT	FM
1.50 in NPT	FO
2.00 in NPT	FQ
Tri-Clamp	
0.5 in	TA
1.0 in	TC
1.5 in	TD
2.0 in	TE
2.5 in	TF
3.0 in	TG
Temperature Range	
-40°C to +100°C (-40°F to +212°F)	S
-60°C to +150°C (-76°F to +302°F)	H
Pressure Range: Standard	S
Electronic Mounting: Remote Junction Box	A
Electrical Safety (See “ELECTRICAL SAFETY SPECIFICATIONS” Section)	
CSA/CSAus Intrinsicly Safe Class I, Division 1/Zone 0, Groups C, D	CAA
ATEX Intrinsicly Safe Ex ia/ic, Group IIB	AAA
IECEx Intrinsicly Safe Ex ia/ic, Group IIB	EAA
No electrical certification	YYY
Optional Selections	
Heating Jacket (c)	-A
Example: CFS25-028KHAEHSACAA-A	

- a. The flowtube is not supplied with cable for transmitter interconnection. Standard cable can be ordered separately. See “ACCESSORIES – CABLES” on page 10 for ordering information.
- b. Contact Global Customer Support for availability of specific end connections for each flowtube model.
- c. For -028K model only; contact Global Customer Support for availability with other flowtube sizes.

ACCESSORIES – CABLES

Flowtubes are not supplied with cables for connection to the transmitter. Cabling options are included in the transmitter model code; additional cables can be ordered separately by part number.

PVC Cable

Five twisted pairs of PVC-insulated, 22 AWG stranded, tinned, copper wire. Each pair has an aluminum-polyester shield with drain wire. Cable has a chrome-PVC outer jacket with ambient temperature limits of -20 to +80°C (-4 to +176°F). One end of cable is dressed and ready for connection to transmitter. Voltage rating is 30 V ac.

Table 4. Transmitter Cable with PVC Insulation

Cable Length	Part Number
20 feet	K0169JN
50 feet	K0169JM
100 feet	K0169JL
6 meters	K0169JN
15 meters	K0169KD
30 meters	K0169KC

FEP Cable

Five twisted pairs of FEP-insulated 22 AWG stranded, tinned, copper wire. Each pair has an aluminum-polyester shield with drain wire. Cable has an FEP outer jacket with ambient temperature limits of -40 to +85°C (-40 to +185°F). One end of cable is dressed and ready for connection to transmitter. Voltage rating is 30 V ac.

Table 5. Transmitter Cable with FEP Insulation

Cable Length	Part Number
20 feet	K0169JX
50 feet	K0169JW
100 feet	K0169JV
6 meters	K0169JX
15 meters	K0169KL
30 meters	K0169KK

DIMENSIONS – NOMINAL

Junction box measurements are the same for all CFS25 flowtube models. Temperature Range option H adds 295.5 mm (11.6 inches) to overall flowtube height.

CFS25 JUNCTION BOX - STANDARD (S) TEMPERATURE RANGE OPTION

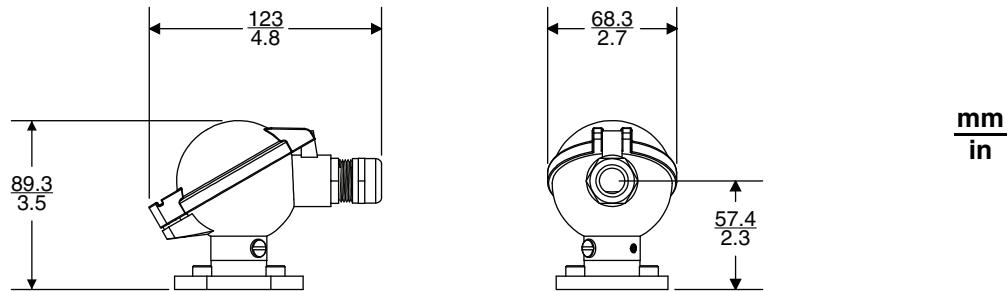

CFS25 JUNCTION BOX - HIGH (H) TEMPERATURE RANGE OPTION

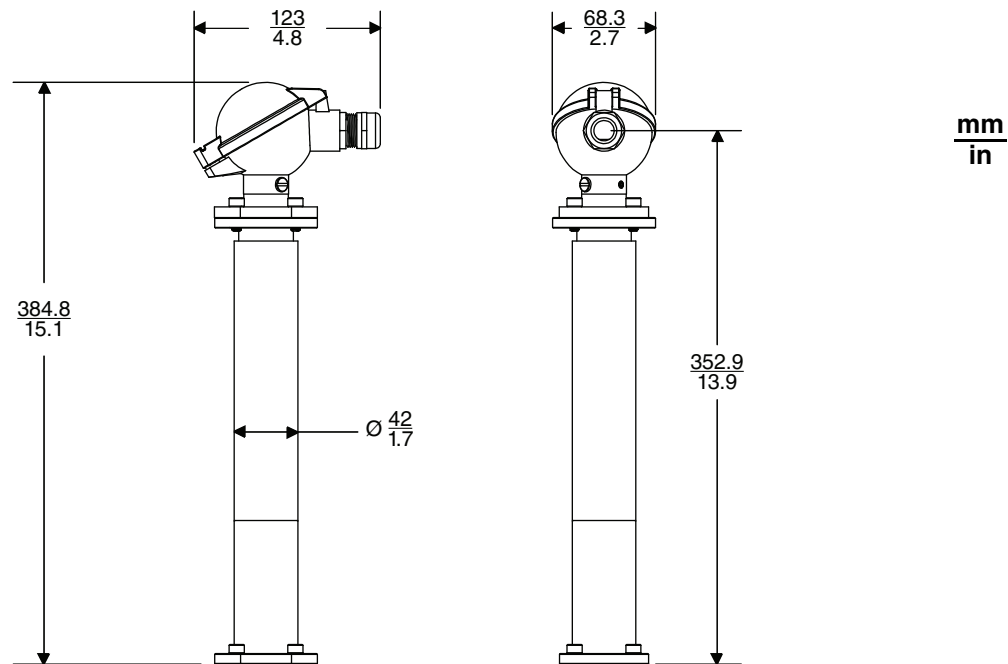

CFS25 FLOWTUBE - 325 TO 3,100 KG/HR NOMINAL CAPACITY
(CFS25-0325SFKSSA SHOWN)

$\frac{\text{mm}}{\text{in}}$

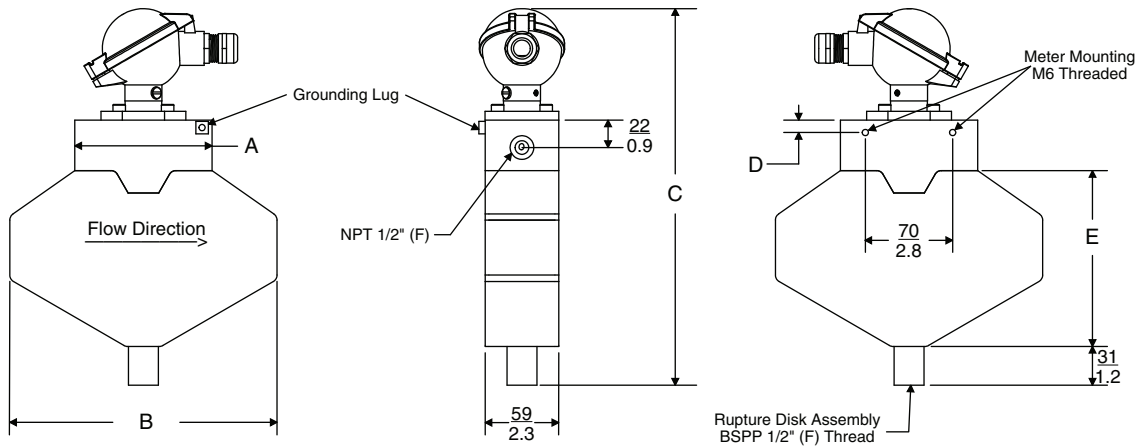

Dimension	CFS25-0325 CFS25-0650	CFS25-1550 CFS25-3100
A (a)	110 mm (4.3")	140 mm (5.5")
B	214 mm (8.4")	350 mm (13.8")
C (b)	301.8 mm (11.9")	369.6 mm (14.6")
D	10 mm (0.4")	9.9 mm (0.4")
E	141 mm (5.6")	236.5 mm (9.3")

- a. This dimension varies according to the End Connection selected in the Model Code. Measurements shown are for option FK, a female 1/2 NPT connection. Other connection types may be wider. Refer to DP 019-186 for additional dimensions, or contact Global Customer Support for details.
- b. Overall height measurement is for the standard (S) Temperature Range option. Add 295.5 mm (11.6 inches) for high (H) Temperature Range option. See junction box diagrams for additional dimensions.

CFS25 FLOWTUBE - 5,500 TO 65,000 KG/HR NOMINAL CAPACITY
(CFS25-028KSAESSA SHOWN)

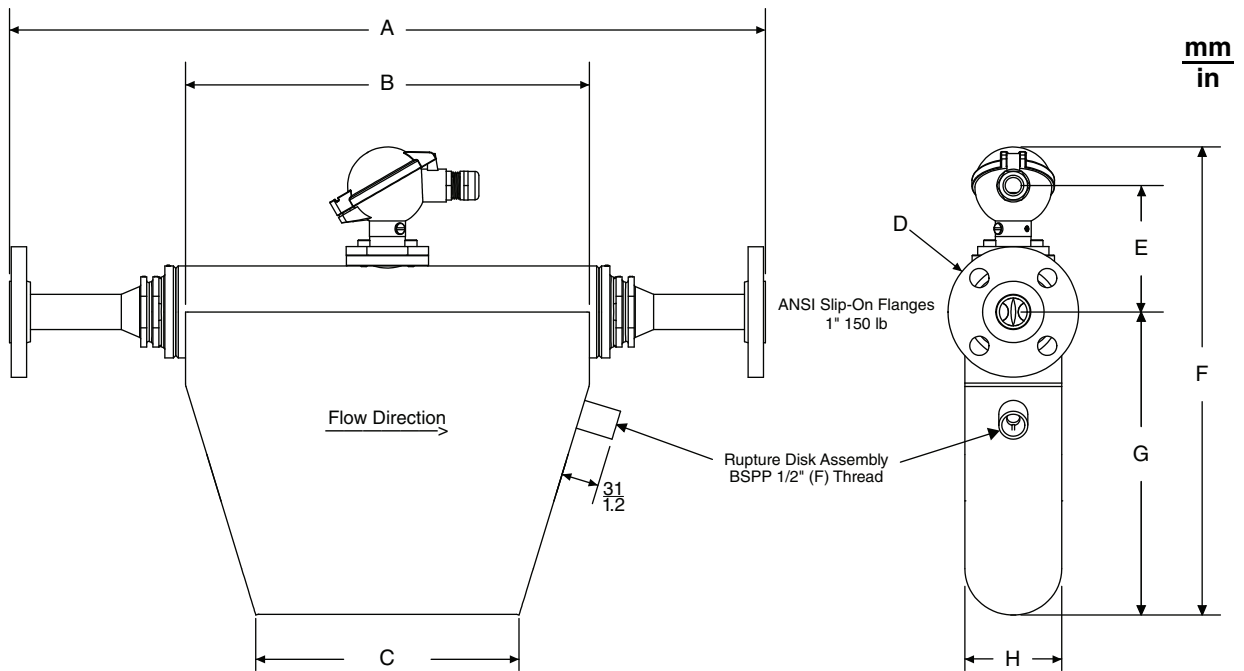

Dimension	CFS25-5500 CFS25-7900	CFS25-028K	CFS25-065K
A (a)	460 mm (18.1")	625 mm (24.6")	830 mm (32.7")
B	294 mm (11.6")	334 mm (13.1")	539.1 mm (21.2")
C (b)	198.8 mm (7.8")	217.6 mm (8.6")	360.2 mm (14.2")
D (a)	Flange diameter is 108 mm (4.3") for 1 inch, 150 Class ANSI flange. All flange dimensions are standard for ANSI B16.5.		
E (b)	94.9 mm (3.7")	104.5 mm (4.1")	132.9 mm (5.2")
F (b)	322.8 mm (12.7")	387 mm (15.2")	548.9 mm (21.6")
G	196 mm (7.7")	250.6 mm (9.9")	384.1 mm (15.1")
H	61 mm (2.4")	80.1 mm (3.2")	137 mm (5.4")

- a. This dimension varies according to the End Connection selected in the Model Code. Measurements shown are for option AE, a 1-inch ANSI B16.5 150 Class flange. Other connection types may have different measurements. Refer to DP 019-186 for additional dimensions, or contact Global Customer Support for details.
- b. Height measurements are for the standard (S) Temperature Range option. Add 295.5 mm (11.6 inches) for high (H) Temperature Range option. See junction box diagrams for additional dimensions.

NOTES

ORDERING INSTRUCTIONS

1. Model Number of Flowtube
2. Part Number of Cable, if required
3. Model Number of CFT51 Transmitter, if required; see PSS 1-2B7 C
4. Flow Data (rate, pressure, temperature, etc.)
5. User Tag Data

OTHER FOXBORO PRODUCTS

The Foxboro product lines offer a broad range of measurement and instrument products, including solutions for pressure, flow, analytical, temperature, positioning, controlling, and recording. For a list of these offerings, visit our web site at:

www.fielddevices.foxboro.com