

FIELD BUS ABSOLUT ENCODERS

PROFIBUS

Profibus DP is a digital communications network that connects and is useful as a communication network between industrial controllers and Input/Output devices. Each device is a node in the network and should be identified unmistakably. Profibus DO is a network in the form of "master-server" with a token bus that is compatible with multiple hierarchies and message prioritizations.

We can connect up to 32 elements (master or slave) in one sole network segment. If you wish to install more than 32 elements, repeaters should be used in order to interconnect the different segments. The network should be finished at the beginning and the end of each segment with an active bus termination.

The encoder presents a bus termination in the inside of it or an external one can be installed.

The following functionalities are integrated in the encoders Profibus Hohner:

- Galvanic isolation of the bus with DC/DC
- Line Driver according to RS-485. max. 12MB

- Diagnosis led: Indication led of functioning state and the power supply led.
- Direction programmable by micro switches. The allowed value range is from 1...126. Each node number should be used one sole time in one network. During the initialization of the encoder, the micro switches are read by the firmware.
- The communication velocity is adjusted by the software. Normally the master of the system adjusts it. All of the modules in the same segment of the Profibus network should be adjusted to the same communication velocity.
- They can be programmed in accordance with the profile of the Profibus encoder in Class 1 and Class 2.

Configurable parameters:

- Rotation direction
- Scaling factor
- Number of positions per turn and total resolution
- Preset value.
- Diagnosis mode.

DEVICENET

DeviceNet is a digital communications network that connects and is useful as a communication network between industrial controllers and Input/Output devices. Each device is a node in the network and should be identified unmistakably. DeviceNet is a network in the form of "producer-consumer" with a token bus that is compatible with multiple hierarchies and message prioritizations. DeviceNet can be configured to operate in the "master-slave" mode using "point to point" messages. Device Net supports the capacity of having a power supply integrated in its bus, which allows reducing the connection points

The following functionalities are integrated in the Devicenet Hohner encoders:

- We can have up to 64 nodes (0...63). Each Node Number should be used one sole time in one network. During the initialization of the devices the Node Number micro switches are read by the firmware.
- Galvanic isolation with DC/DC

- A Bus termination resistance is available and can be selected by the micro switch
- Communication modes: polled, cyclic and cos.
- Communication velocity selectable through micro switches: 125 kBits/sec, 250 kBits/sec or 500 kBits/sec.

Configurable parameters:

- Rotation direction.
- Scaling factor
- Number of positions per turn and total resolution
- Preset.
- Diagnosis mode.

CANOPEN

CANOpen is a digital communications network that connects and is useful as a communication network between industrial controllers and Input/Output devices. Each device is a node in the network and should be identified unmistakably.

CANOpen is a network in the form of "producer-consumer" with a token bus that is compatible with multiple hierarchies and message prioritizations.

CANOpen can be configured to operate in the "master-slave" mode using "point to point" messages.

CANOpen supports the capacity of having a power supply integrated in its bus, which allows reducing the connection points

The following functionalities are integrated in the CANOpen encoders:

- We can have up to 64 nodes (0...63). Each Node Number should be used one sole time in one network.

During the initialization of the devices the Node Number micro switches are read by the firmware.

- A Bus termination resistance is available and can be selected by the micro switch
- Communication modes: polled, cyclic and cos.
- Communication velocity selectable through micro switches: 10...1000 kBits/sec

Configurable parameters:









- Rotation direction.
- Scaling.
- Number of pulses per turn and number of turns
- Total resolution
- Preset.
- Offset

ABSOLUT ENCODERS **FIELDBUS**

- Resolution up to 25 bits
- Solid or blind hollow shaft
- Protection class IP65 according to DIN 40050
- Any number of positions per turn available
- Interface: Devicenet, Canopen and Profibus
- Industrial plug connection



OVERVIEW

	Clamping	Synchro	Blind hollow
Devicenet	CM10 	CM10 	HM10 
Canopen	CM10 	CM10 	HM10 
Profibus	CM10 	CM10 	HM10 

TECHNICAL SPECIFICATIONS

Housing	Aluminium
Shaft	Stainles steel
Bearings	Ballraces
Bearings lifetime	1x10 ¹⁰ rev.
Maximum number of revolutions permitted mechanically	6000 rpm.
Protection against dust and splashes according to DIN 40050	IP65
Rotor inertia moment	30 gcm ²
Starting torque a 20°C (68°F)	Max. 2,0 Ncm
Maximum load permitted on axial shaft	40 N.
Maximum load permitted on radial shaft	60 N.
Misalignment permitted axial (blind hollow shaft)	±0.5 mm
Misalignment permitted radial (blind hollow shaft)	±0.3 mm
Weight aprox.	400 g ST, 500 g MT
Operating temperature range	-10°C a +70°C
Vibration	100 m/s ² (10Hz...2000Hz)
Shock	1000 m/s ² (6ms)
Consumption max	100 mA (CS/HS), 150 mA (CM/HM)
Power supply	10..30Vdc
Interface	Devicenet, CanOpen, Profibus
Max. points per turn	8192 positions (13 bits)
Max. turns	4096 turns (12 bits)
Linearity	±1/2 LSB
Radial connection	Industrial connector

ST: Singleturn MT: Multiturn

hohner
AUTOMATICOS S.L.

MULTITURN ABSOLUT ENCODER

- Devicenet protocol for version 2.0
- Programmable up to 25 bits (8192 points per turn, 4096 turns)
- Protection class IP65 according DIN 40050
- Solid shaft (CM) and blind hollow shaft (HM)

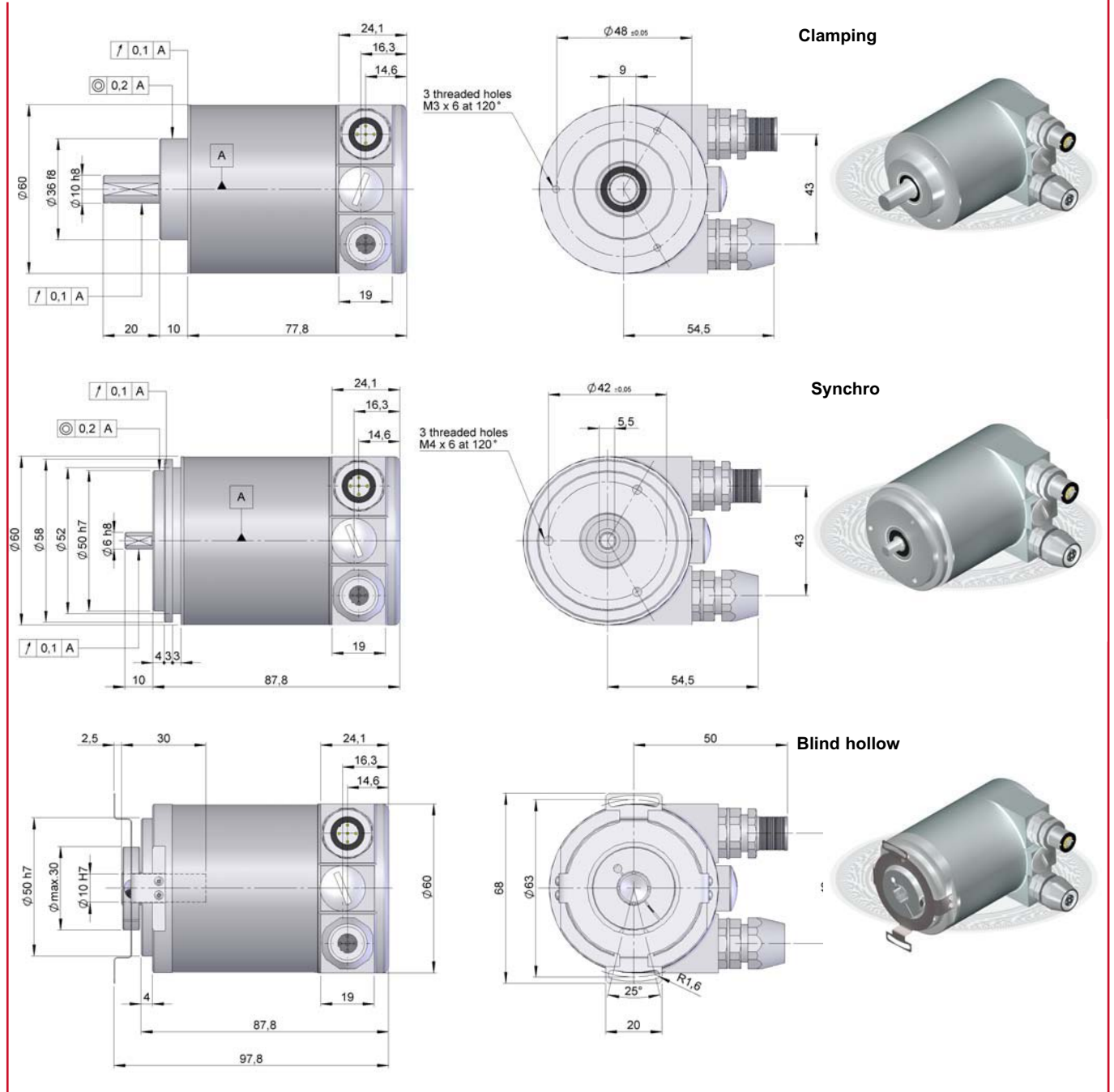

Previous mounting and installation of the encoder is recommended to read the section "TECHNICAL CONSIDERATIONS".

ORDERING CODE

SERIE	FLANGE	SHAFT	PROTOCOL	CONNECTION
CM10- Solid shaft HM10- Blind hollow shaft	1- Clamping 2- Synchro 4- Blind hollow	1- Solid 6 x 10 mm 2- Solid 10 x 20 mm 3- Blind hollow 10 mm 4- Blind hollow 12 mm	1- DeviceNet	2- Connector M12

MULTITURN ABSOLUT ENCODER

- Canopen protocol DSP 406 with additional function
- Programmable up to 25 bits (8192 points per turn, 4096 turns)
- Protection class IP65 according DIN 40050
- Solid shaft (CM) and blind hollow shaft (HM)

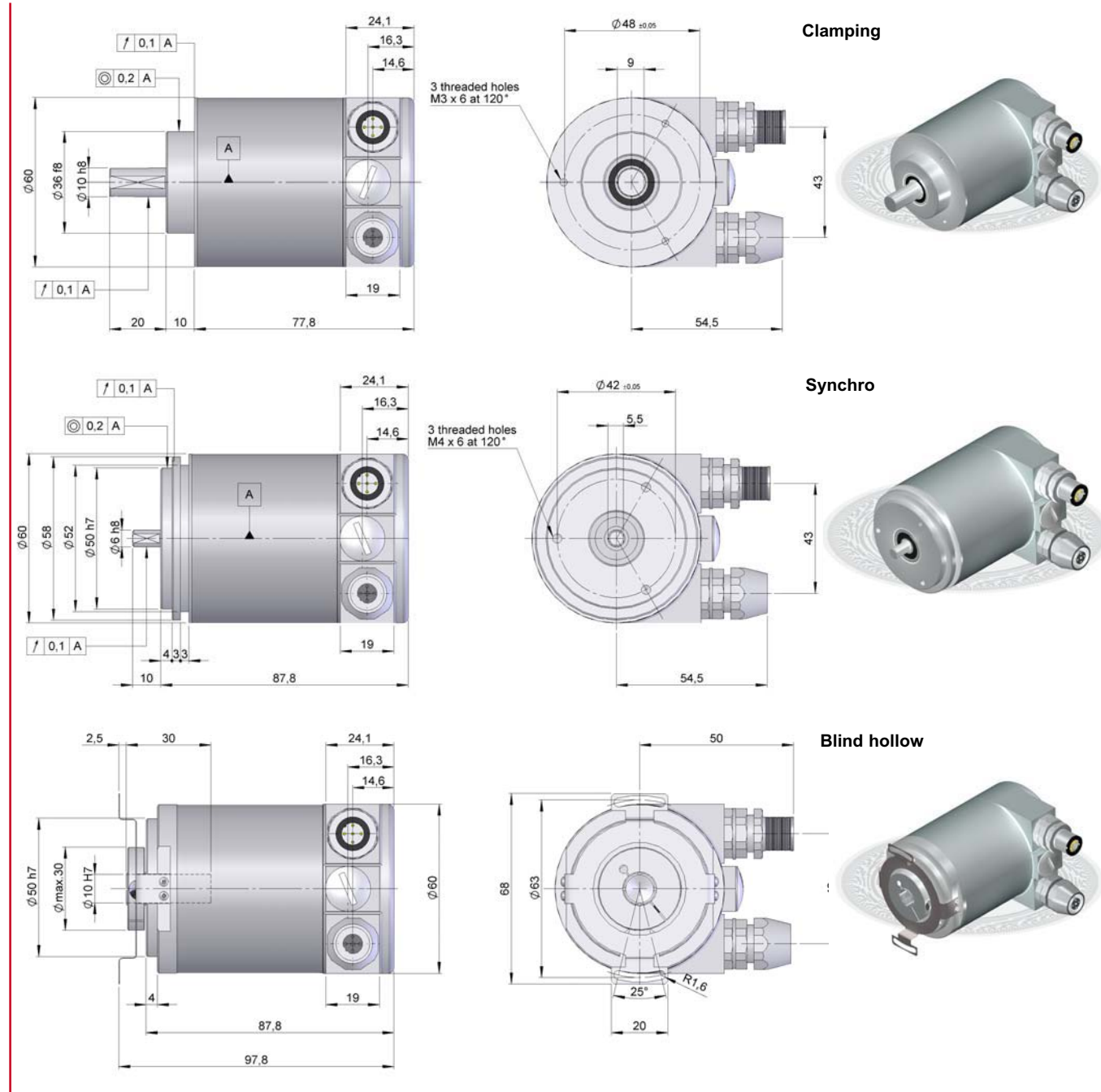

Previous mounting and installation of the encoder is recommended to read the section "TECHNICAL CONSIDERATIONS".

ORDERING CODE

SERIE	FLANGE	SHAFT	PROTOCOL	CONNECTION
CM10 - Solid shaft	1- Clamping	1- Solid 6 x 10 mm	2- CANOpen	2- Conector M12
HM10 - Blind hollow shaft	2- Synchro	2- Solid 10 x 20 mm		
	4- Blind hollow	3- Blind hollow 10 mm		
		4- Blind hollow 12 mm		

MULTITURN ABSOLUT ENCODER

- Profibus DP protocol
- Programmable up to 25 bits (8192 points per turn, 4096 turns)
- Protection class IP65 according DIN 40050
- Solid shaft (CM) and blind hollow shaft (HM)

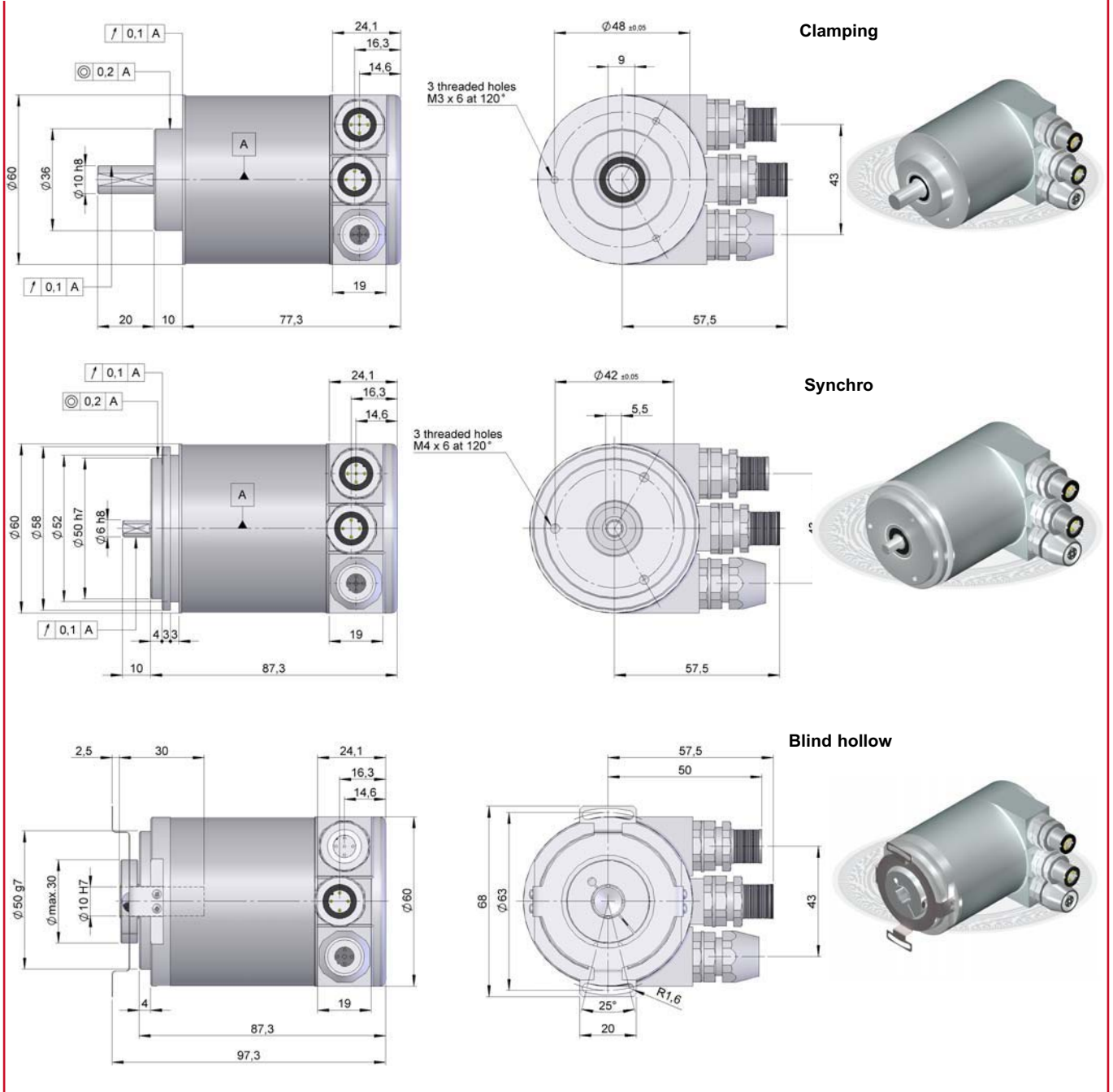

Previous mounting and installation of the encoder is recommended to read the section "TECHNICAL CONSIDERATIONS".

ORDERING CODE

SERIE	FLANGE	SHAFT	PROTOCOL	CONNECTION
CM10- Solid shaft HM10- Blind hollow shaft	1- Clamping 2- Synchro 4- Blind hollow	1- Solid 6 x 10 mm 2- Solid 10 x 20 mm 3- Blind hollow 10 mm 4- Blind hollow 12 mm	3- Profibus-DP	1- Terminal box 2- Connector M12

CONNECTION

DEVICENET AND CANOPEN CONNECTION



90.9550 y 90.9551		Cable	
M12	5p		
1		Grey	Screen
2		Red	+Vcc
3		Black	-Vcc
4		White	CAN_High
5		Blue	CAN_Low

PROFIBUS CONNECTION



90.9553		90.9552		90.9554	
BUS OUT		BUS IN		POWER SUPPLY	
1	BUS_Vcc	1	-	1	+Vcc
2	BUS A	2	BUS A	2	-
3	BUS_Gnd	3	-	3	-Vcc
4	BUS B	4	BUS B	4	-
5	Screen	5	Screen		

PROFIBUS CONNECTION TERMINAL BOX OUTPUT

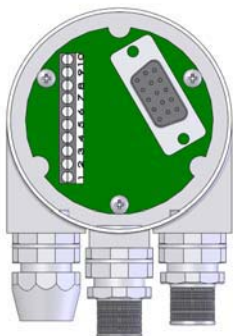

Pin	Function
1	Power supply +10..30 VDC
2	Power supply GND
3	PROFIBUS GND
4	Input PROFIBUS B-Line (PROFIBUS_H)
5	Input PROFIBUS A-Line (PROFIBUS_L)
6	Output PROFIBUS A-Line (PROFIBUS_L)
7	Output PROFIBUS B-Line (PROFIBUS_H)
8	PROFIBUS GND
9	Power supply GND
10	Power supply +10..30 VDC