

I/A Series® Intelligent Magnetic Flow Transmitters
The Model IMT96 MagEXPERT™
with HART or FoxCom™ Communication Protocol for use with 2800 Series Magnetic Flowtubes



TRANSMITTER SHOWN WITH
LCD INDICATOR, 5-BUTTON KEYPAD,
AND OPTIONAL I/O ACCESS PORT

The Foxboro® brand Model IMT96 MagEXPERT Magnetic Flow Transmitter is available from Invensys Process Systems (IPS). It is a significant advancement in magnetic flowmeter technology. When combined with a 2800 Series Magnetic Flowtube, it provides a reliable solution to the most noisy flowmeter applications such as High Consistency Pulp Stock, Slurries, Chemical Additives, and Pulsating Flow. The MagEXPERT uses the IPS patented eX-Pulse coil excitation method to create a strong measurement signal, coupled with optimum noise reduction capability and fast speed of response.

FEATURES

- ▶ Patented eX-Pulse Coil Excitation provides Superior Performance on Liquids with Entrained Air, Non-homogeneous Slurries, Dense Slurries, and Pulsating Flow
- ▶ Backward Compatibility with Existing 2800 Series Flowtubes
- ▶ Unidirectional or Bidirectional Flow
- ▶ Zero Signal Lock Capability
- ▶ Digital, Analog, and Pulse Output Signals
- ▶ Remote Communications via HART or FoxCom protocol using I/A Series Workstation, PC-based Configurator, or HART Communicator.
- ▶ Local configuration also available using integral backlit, 2-line, LCD indicator with keypad, if selected.
- ▶ Quick Start with automatic wiring check.
- ▶ Simple Menu-Driven Configuration via I/A Series System, PC-Based Configurator, or Local On-board LCD Indicator/Keypad

- ▶ Contact Inputs with Programmable Functionality for Remote Operation Capability
- ▶ Relay Outputs with Programmable Functionality for Alarming
- ▶ Software Configuration and Totals Protected in Nonvolatile Memory
- ▶ I/O Access Port Option allows Direct Connection of External PC-Based Configurator
- ▶ Online Diagnostic/Help Capability
- ▶ Complies with NAMUR Standard NE 43.
- ▶ Conforms to Applicable European Union Directives (Product Marked with “CE” Logo)
- ▶ Standard 2-Year Warranty

THE MODEL IMT96 MagEXPERT TRANSMITTER WITH eX-Pulse COIL EXCITATION

The MagEXPERT Transmitter incorporates the patented eX-Pulse coil excitation method. It pulses the coils of a Foxboro 2800 Series Flowtube with unipolar current excitation as shown in Figure 1.

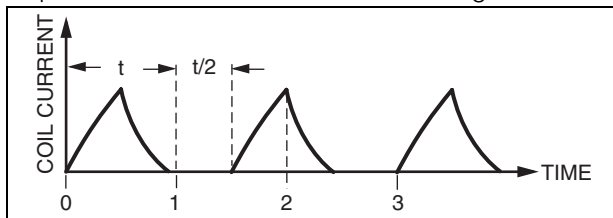

Figure 1. Coil Current versus Time

During an individual pulse, the coil current rises and then falls in an exponential manner. Hence the name eX-Pulse. Coil current pulses start on one and one-half (1 1/2) line cycle intervals. The additional 1/2 cycle introduces a reversal of the power line to flow signal on every pulse. This cancels the effect of power line voltage coupling to the flow signal.

The MagEXPERT is neither an ac transmitter, nor is it a pulsed dc transmitter. eX-Pulse excitation is a true technology advancement that combines the best from both ac and dc systems. MagEXPERT is similar to a pulsed dc transmitter in that it supplies power to

the flowtube coils. This power is pulsed on/off to achieve zero stability (high precision), and the unit consumes low power. Also, MagEXPERT is similar to a conventional ac transmitter (like the Foxboro E96 Series) in that:

- ▶ Flow signal is integrated over the entire pulse cycle
- ▶ Speed of response is fast
- ▶ Flow signal is high, similar to conventional ac systems
- ▶ And measurement frequency is high (2/3 of the power supply frequency – 40 Hz at 60 Hz supply power).

The Foxboro Model IMT25 Pulsed dc Transmitter still remains the most cost effective solution for general magnetic flow applications. However, the MagEXPERT Transmitter has superior capability to handle more difficult applications, such as liquids with entrained air, dense slurries, nonhomogeneous slurries, pulsating flow created by positive displacement type pumps, and applications where chemical additives create excessive noise.

CALIBRATION

All MagEXPERT Magnetic Flow Transmitters are factory calibrated to their specified accuracy with calibration equipment traceable to the U.S. National Institute of Science and Technology (NIST).

A SELECTION OF OUTPUT SIGNALS

The MagEXPERT Transmitter provides digital, analog, and pulse output signals.

The Digital Output Signal utilizes either HART or FoxCom communication protocol. The digital signal provides transmission of the flow signal and allows remote communications/configuration of the transmitter. The 1200 baud HART digital signal allows remote communications with the HART Communicator. Alternatively, FoxCom

communication can be performed on an I/A Series System Workstation or a PC-based Configurator at any point in the loop; the FoxCom output signal has a 4800 baud transmission rate.

The Analog Output Signal is 4 to 20 mA and can be configured to operate in one of four ways: unidirectional (single range), unidirectional (multiple range), bidirectional, and bidirectional split range. The transmitter can be programmed for up to three different flow ranges when measuring flow in one direction. For bidirectional flow, the user can input a separate flow range for the forward and reverse directions. Alternatively, the output can be programmed as bidirectional split flow, where 12 mA represents zero flow, 4 mA represents the reverse flow upper range value, and 20 mA the forward flow upper range value. The analog output can be either internally or externally powered, and is independently isolated. A digital signal is superimposed on the analog signal for remote communications. The 1200 baud HART digital signal permits simultaneous use of the analog output. The superimposed FSK signal has a 600 baud transmission rate using FoxCom. The analog output signal is not available simultaneously with the FoxCom high baud (4800) digital output signal.

The Pulse Output Signal can be configured for frequency mode or scaled pulse mode. It is independently isolated from power ground and can be internally or externally powered. Frequency mode would be selected, for example, to drive an external rate meter. Maximum output frequency is selectable between 1000 and 10 000 Hz. Scaled pulse mode would be selected, for example, to drive an external totalizer. Maximum output frequencies of 10 and 100 Hz are available. Pulse output is available simultaneously with either analog or digital output.

COMPARISON OF MagEXPERT eX-Pulse TRANSMITTER WITH CONVENTIONAL ac AND PULSED dc TRANSMITTERS

Transmitter Feature	ac	Pulsed dc	eX-Pulse
Zero Stability	–	yes	yes
High Signal Strength	yes	–	yes
Low Power Consumption	–	yes	yes
Accuracy Better than 1%	–	yes	yes
Simplified Wiring and Installation	–	yes	yes
Immunity from External Power Line Effects	–	yes	yes
Digital Communications and Advanced Features	–	yes	yes
Measurement of Pulsating Flow	yes	limited	yes
Measure Noisy Fluids (e.g., slurries)	yes	limited	yes
Measurement of Liquids with Entrained Air	yes	limited	yes
Backward Compatibility to Foxboro Flowtubes	–	yes	yes

COMPATIBILITY OF MagEXPERT WITH FOXBORO FLOWTUBES

The MagEXPERT should be used with 15 to 900 mm (1/2 to 36 in) 2800 Series Magnetic Flowtubes that have been calibrated for use with this transmitter.

It can also be used with existing 2800 Series flowtubes to replace E96 Transmitters, but with reduced specifications (if flowtube has not been calibrated for use with MagEXPERT). However, MagEXPERT will still provide performance equal to or better than the original E96 Transmitter flow system specifications. See table below for 2800 Series Magnetic Flowtube Product Specification Sheets (PSSs).

PSS Number	2800 Series Flowtube Description
PSS 1-6B5 A	1/2 to 12 in Sizes; ptfe or polyurethane linings.
PSS 1-6B5 E	14 to 36 in Sizes; ptfe, neoprene, or polyurethane linings.
PSS 1-6B5 C	1/2 to 3 in Sizes; ptfe lining, Sanitary End Connections.

AUTOMATIC OR MANUAL ZERO LOCK

Automatic or Manual Zero Lock can be used to lock all rate outputs at zero percent (zero flow) and freeze all totals. The display indicates when the zero lock is activated. In Manual mode, the zero lock can be activated/deactivated at any time by an external contact closure supplied by the user. In the Automatic mode, it can be used to issue an alarm and/or lock all outputs when an increase in electrode impedance is detected, such as can occur when a pipe is empty.

CONTACT INPUTS AND RELAY OUTPUTS

The MagEXPERT Transmitter can accept two contact inputs. The functions of these inputs are programmable, and allow the user to perform transmitter operations from a remote location. Some applications of these inputs include: selection of flow range, resetting totals, acknowledging alarms, and providing an empty tube zero lock on all outputs. Both contacts must be used for multiple range service.

This transmitter also provides two relay outputs with programmable functionality. These outputs can be used to indicate reverse flow, to indicate alarm conditions (high flow rate, low flow rate, or high flow totals), and/or to indicate diagnostic alarms.

The contact inputs and relay outputs can be used together to perform simple sequencing tasks as well.

CE COMPLIANCE

These transmitters display the “CE” designation indicating conformance to the appropriate European Community Standards, for immunity to sources of EMI and conformance to RF emission limits.

LOCAL OPERATION OPTIONS

The door can be supplied blind, or with a local Keypad/LCD Indicator. The keypad is accessible from the front of the transmitter without opening the housing door. A hinged protective clear plastic window guard (to protect the Keypad/LCD Indicator) and I/O Access Port are other available door options.

The Keypad/LCD Indicator consists of a 32 alphanumeric character, 2-line, backlighted display and 5-button keypad. The display characters are 10 mm (0.4 in) high and can indicate positive total, negative total, net total, net inventory total, and rate in conventional flow units. A “+” or “-” indicator shows flow direction. This option allows the transmitter to be used as a stand-alone device, giving the user complete operation and configuration capabilities.

Eight digits are available to display positive, negative and net totals. Ten digits are available to display net inventory total. Six digits are available to display rate.

The optional Clear Plastic Guard protects the LCD Indicator during washdown operations to prevent inadvertent activation of the keypad by the washdown stream. The Clear Plastic Guard is not required to obtain the NEMA 4X protection.

The optional I/O Access Port is a circular recess in the front door that is protected by a separate cover integrally connected to the front door to prevent loss or misplacement. Access to the port is made by loosening a screw on the port cover. Inside the port are two banana plug sockets that allow direct connection to a PC-Based Configurator.

NOISE REDUCTION ALGORITHM

The MagEXPERT provides superior performance in noise generating processes (without the need for high damping constants) by use of an exclusive noise reduction algorithm. The high signal strength resulting from eX-Pulse coil excitation, combined with the noise reduction algorithm, results in a system with fast speed of response on even the most difficult processes.

TRANSMITTER ENCLOSURE

The transmitter enclosure is fitted with a hinged front cover that provides easy access to the wiring terminals. The enclosure electronics are protected by internal plastic covers. The enclosure can be mounted to a flat surface, recessed into a panel, or mounted to a nominal DN 50 or 2-inch pipe. The cast aluminum enclosure has a high build epoxy paint finish. Four conduit/cable access holes are provided (nonthreaded) that accept standard 1/2-inch or M20 fittings. The enclosure is dusttight and weatherproof per ICE IP66, and provides the watertight and corrosion resistant protection of NEMA Type 4X.

SIMPLE SETUP WITH INTEGRAL HELP FUNCTION

The MagEXPERT Transmitter uses the same configuration software, with a few minor exceptions, as the IMT25 Transmitter. Any user familiar with the IMT25 should be able to operate the MagEXPERT right out of the box, without any additional training.

Communication can be done with a PC-based Configurator, an I/A Series System Workstation, HART Communicator, or the local keypad/LCD Indicator. For a basic flow measurement with a 4 to 20 mA or digital output, the setup is very simple, requiring only the Flowtube Calibration Factor and your Upper Range Value (URV) to be entered. A simple Quick Start pamphlet (located in a plastic

jacket on the inside surface of the door) describes how to enter these values.

The transmitter is a very versatile instrument and can provide many different functions in addition to simple flow measurement. To activate these features, additional configuration is needed. To simplify this task, the instruction book shipped with your instrument contains function-specific road maps and instructions to get you started.

ON-LINE DIAGNOSTICS WITH INTEGRAL HELP FUNCTION

While in the Measurement mode, the transmitter continuously performs a number of internal diagnostic functions. The indicator automatically displays any diagnostic condition that is detected, and can actually be programmed to blink for a diagnostic error to easily draw the attention of floor personnel. In addition, it can be programmed to energize one or both alarm relays for a diagnostic error.

Diagnostic error messages are reported on the display in clear sentence text. Each diagnostic error has an associated help message that can be displayed by pressing the HELP key whenever the diagnostic prompt appears on the display. The help message gives the user more detailed information on the detected problem, as well as potential trouble shooting techniques to eliminate the problem.

OPERATING CONDITIONS

Transmitter Influence	Reference Operating Conditions	Normal Operating Condition Limits	Operative Limits
Ambient Temperature	23 ±2°C (73 ±3°F)	-20 and +55°C (-4 and +131°F)	-30 and +60°C (-22 and +140°F)
Relative Humidity	50 ±10%	5 and 100%(a)	5 and 100%(a)(b)
Power Input	120 or 240 V ac, 60 Hz	+10% and -15% ±5%	+10% and -15% ±5%
	230 V ac 50 Hz	±10% ±5%	±10% ±5%
4 to 20 mA Output(c) ▶ Supply Voltage ▶ External Load	▶ 24 V dc ▶ 250 ohms	▶ 10 and 50 V dc ▶ 0 and 1950 ohms	▶ 10 and 50 V dc ▶ 0 and 1950 ohms
Pulse Output ▶ Supply Voltage ▶ External Load	▶ 24 V dc ▶ 480 ohms	▶ 5 and 42 V dc ▶ 62.5 and 5000 ohms	▶ 5 and 42 V dc ▶ 62.5 and 5000 ohms

(a) Relative humidity limits listed apply only with transmitter door properly installed and closed.

(b) During transmitter transportation or storage, the relative humidity is 0 and 100%.

(c) Refer to Figure 2 for plot of supply voltage vs. external load.

PERFORMANCE SPECIFICATIONS

(AT REFERENCE OPERATING CONDITIONS, SYSTEM PERFORMANCE OF COMBINED TRANSMITTER AND FLOWTUBE, UNLESS OTHERWISE SPECIFIED)

Accuracy – Digital and Pulse Outputs

Flow System	Tube Size	System Accuracy(a)(b)	Flow Velocity
2800 Series Flowtube Factory Calibrated for MagEXPERT(c)	15 to 300 mm (1/2 to 12 in)	±0.50% of rate ±0.010 fps (±0.00305 mps)	≥2.0 fps (0.61 mps) <2.0 fps (0.61 mps)
	400 to 900 mm (14 to 36 in)	±1.0% of rate ±0.02 fps (±0.006 mps)	≥2.0 fps (0.61 mps) <2.0 fps (0.61 mps)

(a) To obtain Analog Output accuracy, add ±0.03% of span (equal to ±0.0048 mA) to the Digital/Pulse Output accuracy listed above.

(b) Accuracy listed is with zero flow setting.

(c) You can use MagEXPERT (IMT96) with a 2800 Series Flowtube that has not been factory calibrated; the expected accuracy value in this case is 0.5% greater than that shown. Accuracy specified is based on a nominal factor determined by calculation using the actual calibration factor from the tube to be retrofitted.

PERFORMANCE SPECIFICATIONS (CONT.)

Accuracy - Definitions

- ▶ Accuracy specified using water as the fluid at reference operating conditions
- ▶ Accuracy rating is specified based upon 2800 Series Flowtube sizes 15 to 900 mm (1/2 to 36 in), that have been factory calibrated for the MagEXPERT Transmitter
- ▶ Accuracy includes effects of hysteresis, linearity, zero error, and repeatability
- ▶ Accuracy assumes no flange piping mismatch. It also assumes that there is a straight pipe upstream (5 pipe diameters minimum), and downstream (3 pipe diameters minimum), measured from center of flowtube

Response Time^(a)

Digital and Pulse Outputs		Analog Output	
50 Hz	60 Hz	50 Hz	60 Hz
0.03 s	0.025 s	0.18 s	0.175 s

(a) The interval of time between the initiation of the input step and the time at which the output signal first attains 90% of its final steady state value.

Ambient Temperature Effect

(For any variation from Reference Operating Temperature within Normal Operating Limits)

DIGITAL AND PULSE OUTPUTS

<0.5% of reading, or <0.01% of maximum URV, whichever is greater

ANALOG OUTPUT

0.1 mA plus Digital and Pulse Outputs Effects listed above.

Supply Voltage Effect

A change in the supply voltage of +10% or -15% (+10% or -10% for 230 V ac) from the Reference Operating Voltage causes the output to change less than 0.1% or 0.15% of reading, or 0.001% or 0.0015% of maximum URV, whichever is greater.

Relative Humidity Effect

A change in the relative humidity from 5% to 95% at 30°C (85°F) wet bulb temperature causes the output to change less than 1% of reading, or 0.01% of maximum URV, whichever is greater.

Signal Cable and Fluid Conductivity Effect

Refer to Functional Specifications section for effects relating to long signal cables (> 500 ft [$>$ 150 m]), and/or low fluid conductivities (< 20 μ S/cm).

Electromagnetic Compatibility (EMC)

ELECTROSTATIC DISCHARGE (ESD) IMMUNITY

Contact discharge of 6 kV per IEC 1000-4-2 (EN 61000-4-2)

RADIATED RF IMMUNITY

10 V/m per IEC 1000-4-3 (EN 61000-4-3)

ELECTRICAL FAST TRANSIENTS/BURST IMMUNITY

2 kV per IEC 1000-4-4 (EN 61000-4-4)

SURGE WITHSTAND IMMUNITY

2 kV per IEC 1000-4-5 (EN 61000-4-5)

CONDUCTED RF IMMUNITY

Per IEC 1000-4-6 (EN 61000-4-6)

MAGNETIC FIELD IMMUNITY

20 gauss per IEC 1000-4-8 (EN 61000-4-8)

POWER DIPS AND INTERRUPTIONS

Per IEC 1000-4-11 (EN 61000-4-11)

RADIATED AND CONDUCTED EMISSIONS

Per IEC CIS PR 11, Class A (EN 55011)

FUNCTIONAL SPECIFICATIONS

Flow Rate Limits (Velocity)

MAXIMUM VELOCITY

10 m/s (33 ft/s)

MINIMUM UPPER RANGE VELOCITY FOR 100% OUTPUT

0.5 m/s (1.65 ft/s)

MINIMUM MEASURABLE FLOW RATE

0.01 m/s (0.033 ft/s)

Low Flow Cut-Off

A low flow cut-off algorithm holds the pulse output, rate indicator, and digital measurement at zero when the measurement signal falls below 0.01 m/s (0.033 ft/s). The analog output remains active at zero flow, unless specifically configured to go to zero when flow rate falls below a user-configured value.

Measurements

FLOW RATE - UNI- OR BIDIRECTIONAL

+ or - Rate in Engineering Units

+ or - Rate in % of Upper Range Value

TOTALIZATION

+ or - Bidirectional Total (8 digits)

Net Total (8 digits)

Net Inventory Total (10 digits)

Power Consumption

Power for the flow measurement system (IMT96 and 2800 Series Flowtube) is less than 100 VA, regardless of tube size.

Output Damping

Field programmable from 0 to 99.9 s. This feature is used for reducing the frequency response of the transmitter as required by the process.

Self Test

In the background to normal flow calculations, the system continuously performs self-test checks. If a fault is found that makes flow calculation impossible, the outputs go "LO" or "HI" based on configuration choice. A diagnostic message identifying the problem is also issued. This message can be read on the local LCD Indicator, with the PC-based Configurator, an I/A Series Workstation, or a HART Communicator.

Preset/Calibration

The transmitter may be used as a 4 to 20 mA or pulse generating source to check and/or calibrate other instruments in the loop, such as indicators, controllers, and recorders. This feature may be activated by pressing keypad buttons. The output signals can also be adjusted to any value, remotely, via the PC-based configurator or HART Communicator.

Ranging

The MagEXPERT Transmitter is easily adjusted for the desired flow rate units and to the required upper range value. This range data may also be keyed in through the PC-based configurator or HART Communicator.

Output Signals

Three electrical output signals are available - Digital, 4 to 20 mA, and Pulse. The Digital Output utilizes either HART or FoxCom protocol. All three output signals are available simultaneously except that the 4 to 20 mA output is not available when HART is configured for Multidrop operation, or with 4800 baud FoxCom.

DIGITAL OUTPUT (4800 BAUD FoxCom)

Transmitter transfers digital information using FoxCom communication protocol.

4 TO 20 MA OUTPUT WITH SUPERIMPOSED DIGITAL OUTPUT (1200 BAUD HART OR 600 BAUD FoxCom)

The current output is independently isolated and can be internally or externally powered. The current output is also configurable to a 4 to 12 and 12 to 20 mA split range for bidirectional flow applications. Minimum current is 3.55 mA and maximum current is 22 mA.

FUNCTIONAL SPECIFICATIONS (CONT.)

PULSE OUTPUT

This is a 2-wire solid state type output, and is configurable as a scaled pulse or frequency output. Pulse output is available simultaneously with 4 to 20 mA or digital output.

Scaled Pulse Output Mode

Speed Selection	Pulse Width	Maximum Frequency
Slow	50.0 ms	10 Hz
Medium	5.0 ms	100 Hz

Frequency Output Mode (Unidirectional Only)

0 Hz to either 1, 2, 5, or 10 kHz, user programmable.

Relay Outputs

Quantity: 2

Relay Type: 1 form A (isolated)

Voltage Rating:

60 V dc maximum

30 V ac rms maximum

Current Rating:

3 A maximum resistive load

Contact Inputs

Quantity: 2

Voltage Rating: 25 V dc max

Current Rating: 15 mA max

Type: Requires current sinking device such as contact closure or transistor switch between terminal block connections provided. The contact inputs share the same circuit reference, but are isolated from the power ground.

Automatic Zero Lock (Empty Tube Zero)

This function automatically drives the analog, pulse, and digital output signals to zero flow rate when the flowtube's electrodes become uncovered by the conductive liquid.

Supply Voltage Requirements and External Loop Load Limitations

The transmitter is capable of switch selectable internally or externally powered outputs.

DIGITAL OUTPUT

Output powered by the MagEXPERT Transmitter or by I/A Series System Workstation

ANALOG OUTPUT (EXTERNALLY POWERED)

Analog output is independently isolated from fluid ground. Figure 2 below is a graph of external supply voltage vs. output load resistance.

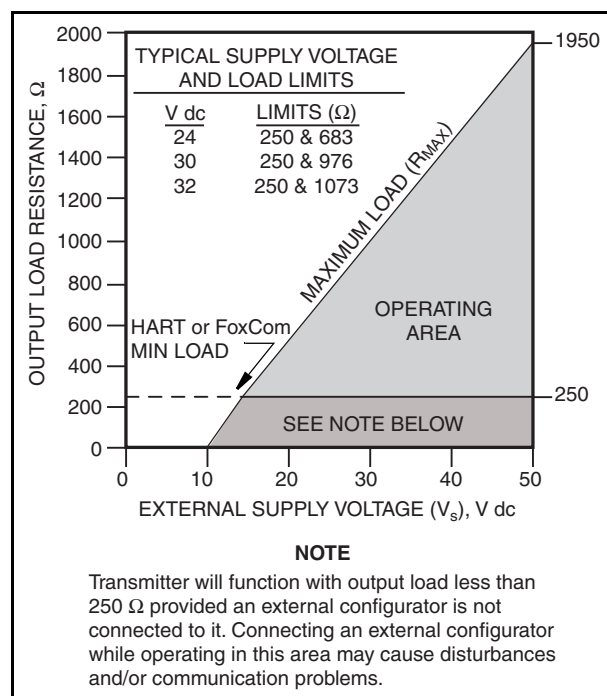

Figure 2. 4 to 20 mA Output, External Supply Voltage vs Output Load Resistance

FUNCTIONAL SPECIFICATIONS (CONT.)

Supply Voltage Requirements and External Loop Load Limitations (Cont.)

ANALOG OUTPUT (INTERNALLY POWERED)

Output may share the same circuit reference as the pulse output, if pulse output is also internally powered. This circuit reference may only be grounded in one location.

Voltage	Load Resistance Range
24 V dc $\pm 15\%$	0 to 500 ohms

NOTES

- 1 A 250 ohm load resistor is required to allow proper communications.
- 2 Load resistance is 300 ohms maximum if the pulse output is also internally powered.

PULSE OUTPUT (EXTERNALLY POWERED)

Output independently isolated from power ground.

Voltage	5 to 42 V dc
Current	80 mA maximum
Off State Leakage	200 μ A maximum

PULSE OUTPUT (INTERNALLY POWERED)

The pulse output may share the same circuit reference as the analog output. This circuit reference can only be grounded in one location.

Voltage	24 V dc $\pm 15\%$
Current	80 mA maximum
Off State Leakage	200 μ A maximum

Diagnostics and Alarms

The transmitter provides a number of internal diagnostics and configurable alarm functions (low flow, high flow, and high totals). The LCD Indicator will automatically indicate any diagnostic or alarm condition that exists. The relay outputs can be configured to activate on an alarm or diagnostic condition to provide remote indication of such events. Also, the output signal can be configured to go upscale, downscale, or remain active when an alarm condition exists. For diagnostic conditions, the output signal can be configured to go downscale or upscale. Diagnostics and alarms are also communicated via the digital output.

Digital Communications

The transmitter communicates bidirectionally over the field wiring to the PC-based Configurator, the HART Communicator, or the DCS (installed anywhere in a Division 2 area along the 4 to 20 mA loop). Using the local display/keypad, or digital communications, the functions that can be performed are:

Display/Reconfigure Measurement Information

- ▶ Flow Rate in EGUs
- ▶ Flow Rate in % of URV
- ▶ Flow Direction
- ▶ Forward, Reverse, Net and Grand Total
- ▶ Flow Rate Damping
- ▶ Meter Factor (Calibration Factor)

Display/Reconfigure Status and Configuration

- ▶ Transmitter Output Mode
- ▶ Outputs
- ▶ Alarm Functions, Set Points, and Deadbands
- ▶ Noise Reduction
- ▶ Automatic-Zero Lock
- ▶ Output Response to Alarms/Diagnostics
- ▶ Passcode Protection
- ▶ Contact Inputs Status and Function
- ▶ Relay Outputs Status and Function

FUNCTIONAL SPECIFICATIONS (CONT.)

Display/Reconfigure Identity

- ▶ Flowtube Model Number
- ▶ Flowtube Serial Number
- ▶ Tag Information
- ▶ Poll Address (HART only)

Display/Operate Diagnostic and Calibration Functions

- ▶ 4 to 20 mA and Pulse Output Present
- ▶ 4 to 20 mA Calibration
- ▶ Online Diagnostics

Communications Format

Both HART and FoxCom protocols are based upon the FSK (Frequency Shift Keying) technique. The FSK tones are superimposed on the transmitter 4 to 20 mA output leads. Communication between the external configurator and the transmitter does not disturb the output signal. Refer to the paragraphs below.

HART AND FoxCom 4 TO 20 OUTPUT WITH SUPERIMPOSED DIGITAL OUTPUT

The transmitter sends its measurement to the loop as a continuous 4 to 20 mA dc signal. This version communicates with the external configurator at distances up to 1800 m (6000 ft). The Digital, 4 to 20 mA, and Pulse Outputs are each updated 10 times/second. The maximum scan frequency for the Digital Output depends upon the baud rate.

HART MULTIDROP COMMUNICATIONS MODE

Either point-to-point (one transmitter) or multidropping is permitted. Multidropping is the connection of several transmitters to a single communications line. Communication between the host computer and transmitters occurs digitally with analog output of transmitter deactivated. With HART communications protocol, up to fifteen transmitters can be connected on a single twisted pair of wires or over leased telephone lines. The maximum cable length conforms to the HART Physical Layer Specification and will vary according to the characteristics of the individual transmitters in a multidrop environment.

FOXCOM DIGITAL OUTPUT MODE ONLY

The transmitter sends measurements to the I/A Series System as a digital signal. Remote communications occur between the transmitter and the PC-based configurator, or any I/A Series System Console up to 600 m (2000 ft) away from the Fieldbus Module (FBM). Other specifications are:

- Data Transmission Rate - 4800 baud
- Scan Frequency - 10 times/second

Functional Block Diagrams

Refer to Figure 3 for a 4 to 20 mA Output functional block diagram for HART and FoxCom, and refer to Figure 4 for a FoxCom Digital Output only functional block diagram.

FUNCTIONAL SPECIFICATIONS (CONT.)

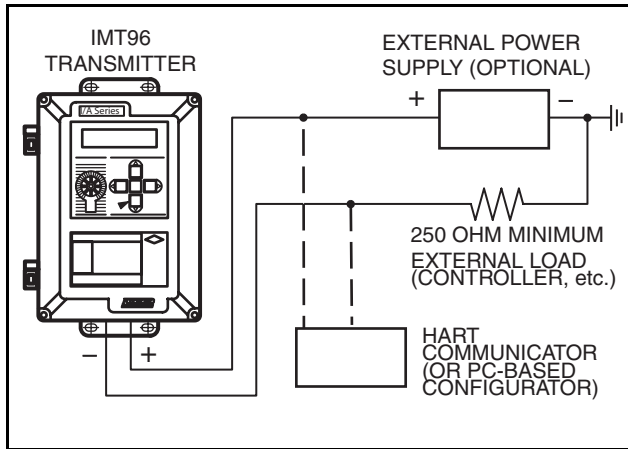

Figure 3. 4 to 20 mA Functional Block Diagram for HART and FoxCom

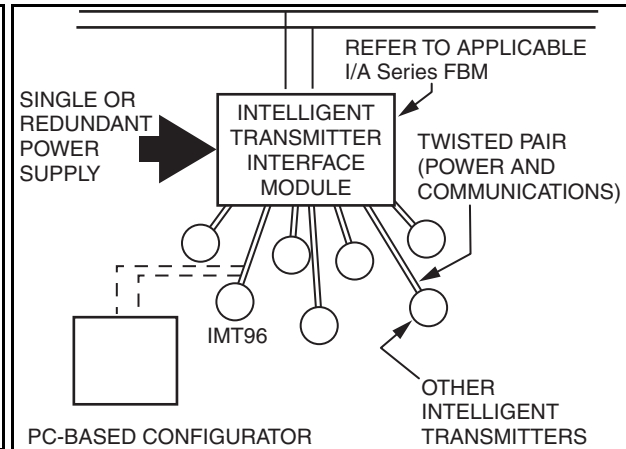

Figure 4. FoxCom Digital Output only Functional Block Diagram

Signal Cable Length & Fluid Conductivity (Note 1)

The limits on cable length and fluid conductivity are 1000 ft (300 m) and 2 $\mu\text{S}/\text{cm}$. However, for cable lengths greater than 500 ft (150 m), or conductivities less than 20 $\mu\text{S}/\text{cm}$, the system accuracy is affected, as indicated in the paragraphs that follow (Note 2).

CABLE LENGTH AND FLUID CONDUCTIVITY TO MAINTAIN STANDARD SYSTEM ACCURACY

If the cable length is less than 500 ft (150 m) and the fluid conductivity is greater than 20 $\mu\text{S}/\text{cm}$, then the standard system accuracy can be maintained with the following wiring:

- ▶ Signal cable is either a Foxboro cable (Note 3) or a good quality twisted shielded pair (Note 4).
- ▶ Coil power wiring is 14 AWG twisted shielded pair (Note 5).
- ▶ Signal and coil powering wiring can be in the same conduit.

CABLE LENGTH EFFECT ON SYSTEM ACCURACY (NOTE 2)

When the cable length is between 500 and 1000 ft (150 and 300 m), an additional error (cable length effect) is introduced. This error, in % of system accuracy, depends on the signal cable used, as follows:

- ▶ Signal Cable Used:
 - Foxboro cable per Note 3; Error is 0.2% for every 100 ft in excess of 500 ft (30 m in excess of 150 m)
 - Shielded cable per Note 4; Error is 0.4% for every 100 ft in excess of 500 ft (30 m in excess of 150 m)
- ▶ Coil power wiring is 14 AWG twisted shielded pair (Note 5)
- ▶ Signal and Coil power wiring can be in the same conduit.

FUNCTIONAL SPECIFICATIONS (CONT.)

FLUID CONDUCTIVITY EFFECT ON SYSTEM ACCURACY (NOTE 2)

For fluid conductivities between 2 and 20 $\mu\text{S}/\text{cm}$, an additional error (fluid conductivity effect) is introduced. This error, in % of standard system accuracy, is equal to 4 divided by the conductivity in $\mu\text{S}/\text{cm}$. For example, if the fluid conductivity is 10 $\mu\text{S}/\text{cm}$, then 4 divided by 10 equals an error of 0.4%. The following wiring must be used:

- ▶ Signal cable is Foxboro cable per Note 3.
- ▶ Coil power wiring is 14 AWG twisted shielded pair per Note 4.
- ▶ Signal and coil power wiring must be in separate conduits.

NOTES

- 1 Refer to TI 027-072 for values of fluid conductivities of over 200 process liquids.
- 2 Apply both the long cable and low conductivity errors, as applicable - they are additive.
- 3 Foxboro signal cable R0101ZS (length ordered in feet), cable B4017TE (same cable, but length ordered in meters).
- 4 Good quality twisted shielded pair, 18 AWG, or larger size; such as Belden 87 □□ Series, and Alpha 56 □□ Series.
- 5 Good quality twisted shielded pair, 14 AWG; such as Belden 8720, or Alpha 5616 B1401.

PHYSICAL SPECIFICATIONS

Transmitter Enclosure

The MagEXPERT Transmitter enclosure is a single compartment design with a hinged front door which houses the electronics, power supply, and all field terminations. Field terminations and electronics are separated for safety reasons. Generous space has been provided around the termination connections to facilitate wiring. The interior compartment is protected by the front gasketed door which seals the unit. The enclosure is weatherproof as defined by IEC IP66, and provides the watertight and corrosion resistance protection of NEMA Type 4X.

Transmitter Mounting (Also see “Dimensions - Nominal” section)

The transmitter can be pipe, surface, wall, or panel mounted. The preferred orientation is vertical to facilitate reading the LCD Indicator and to simplify the opening and closing of the front door.

PIPE MOUNTING

Two integrally cast flanges are provided at the top and bottom rear of the enclosure. These flanges are used for mounting the unit on a nominal DN 50 or 2 in vertical pipe.

SURFACE, WALL, OR PANEL MOUNTING

The two flanges at the top and bottom rear of the enclosure are provided to allow securing of the transmitter to any flat wall, surface, or panel.

Enclosure Material and Finish

Light weight cast aluminum material protected with a high-build epoxy paint finish.

Electrical Connections

The transmitter is supplied with four standard conduit/cable access holes (nonthreaded) sized to accept 1/2 NPT or M20 fittings. Standard wiring termination is to a lug type terminal block as shown in Figure 5. An optional terminal block that provides receptacles for 90° insertion plugs can also be provided and is described in the “Optional Selections” section.

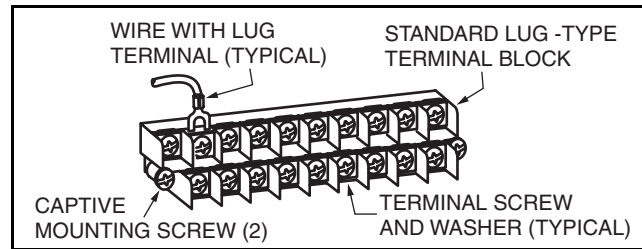

Figure 5. Standard Lug Type Terminal Block
(See Figure 6 for Optional Terminal Block)

Approximate Transmitter Mass

5.2 kg (11.5 lb.)

ELECTRICAL SAFETY SPECIFICATIONS^(a)

Testing Laboratory, Types of Protection, and Area Classification	Application Conditions	Electrical Safety Design Code
CSA certified for use in Class I, Division 2, Groups A, B, C, and D; Class II, Division 2, Groups F and G; and Class III, Division 2 hazardous locations.	Temperature Class T4 at a maximum ambient of 60°C.	L
FM approved nonincendive for use in Class I, Division 2, Groups A, B, C, and D; Class II, Division 2, Groups F and G; and Class III, Division 2 hazardous locations.	<ul style="list-style-type: none"> ▶ Temperature Class T4 at a maximum ambient of 60°C. ▶ With 120 V ac and 230 V ac Supply Voltage only. ▶ Not available with Option -G. 	N
Testing laboratory approval or certification not required.	–	Z

(a) These transmitters have been designed to meet the electrical safety descriptions listed in the table above. For more detailed information, or status of testing laboratory approvals or certifications, contact IPS®.

OPTIONAL SELECTIONS AND ACCESSORIES

Option -A: I/O Access Port

The port contains two banana plug sockets and is used for local connection of PC-based configurators. Access to the plugs are made by unscrewing the cover screw, and removing the cover from the front door. The port cover protects the plugs from the environment. The port cover is also integrally attached to the front door, thus preventing misplacement and loss when removed. Specify optional selection -A.

Option -B: Protective Cover for LCD Indicator/Keypad

This option provides a hinged (upward) clear plastic protective cover for the LCD Indicator/Keypad. This cover protects against inadvertent manipulation of the keys during hose down operations. Specify optional selection -B.

Foxboro Signal Cable

Foxboro two-core (two conductor), multi-screened (multi-shielded) cable with two driven screens (shields). Maximum length is 300 m (1000 ft). This cable needs to be used for installation of an IMT96 transmitter to the flowtube if the fluid conductivity is lower than 20 $\mu\text{S}/\text{cm}$, or if the distance between the flowtube and transmitter exceeds 500 ft (150 m). If ordering the cable in units of feet, order Part Number R0101ZS. If ordering the cable in units of meters, order Part Number B4017TE.

Option -G: Cable Glands for Nonconduit Applications

These cable glands are used to provide a rain tight strain relieved entrance for 6.8 to 12.2 mm (0.27 to 0.48 in.) diameter cable. The body and seal nut are nylon and the compression gland is neoprene. Four cable gland assemblies are provided. Specify optional selection -G.

Option -C: 90° Insertion Type Terminal Block

This option is for those users who prefer an insertion-type terminal block (Figure 6), rather than the standard lug-type terminal block shown in Figure 5. With this insertion-type terminal block, the user inserts the bare end of an insulated wire into an opening on the terminal block, and turns the captive screw until the inserted wire is clamped down within the fixture. Specify optional selection -C.

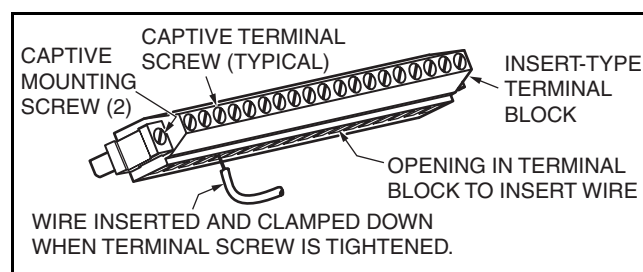

Figure 6. Optional Insert-Type Terminal Block
(See Figure 5 for Standard Lug-Type Terminal Block)

MODEL CODE

Description	Model
I/A Series MagEXPERT Intelligent Magnetic Flow Transmitter	IMT96
Transmitter Mounting Pipe Mounting Surface, Wall, or Panel Mounting	-P -S
Language English Only	E
Nominal Supply Voltage and Frequency 120 V ac, 60 Hz ^(a) 230 V ac, 50 Hz ^(a) 240 V ac, 60 Hz ^(a)	A B C
Communication Protocol FoxCom Communication Protocol HART Communication Protocol	D T
Integral LCD Indicator/Keypad ^(b) No LCD Indicator/Keypad LCD Indicator with Wide Angle Display and Keypad	A B
Transmission Signal Output ^(c) Internally Powered, 4 to 20 mA and Superimposed Digital Signal (1200 Baud HART or 600 Baud FoxCom) Externally Powered, 4 to 20 mA and Superimposed Digital Signal (1200 Baud HART or 600 Baud FoxCom) Internally Powered, Digital Signal; 4800 Baud FoxCom only Externally Powered, Digital Signal; 4800 Baud FoxCom only	1 2 3 4
Pulse Output Signal ^{(c)(d)} OFF Internally Powered, ON Externally Powered, ON	0 1 2
Electrical Safety Classification (Also see Electrical Safety Specifications Section) CSA, Suitable for Class I, II, III, Division 2 FM, Nonincendive, Class I, II, III, Division 2 No Certification Required	L N Z
Optional Selections I/O Access Port LCD Indicator/Keypad Protective Cover Terminal Block for 90° Insertion Plug (Replaces Lug Type Block) Cable Glands (Nonconduit Applications) Not for Electrical Classification Code L or N Not with 240 V ac Supply Voltage	-A -B -C -G
Example: IMT96-PEADB10M-A	

(a) See Operating Conditions Table for tolerances on Voltage and Frequency.

(b) The LCD Indicator has ambient temperature limits of -20 to +70°C (-4 to +158°F).

(c) Internal versus external power can be changed in the field by switch selection.

(d) Pulse output can be configured as either a scaled Pulse Output, or a Frequency Output.

DIMENSIONS - NOMINAL

**mm
in**

SURFACE, WALL, AND PIPE MOUNTING

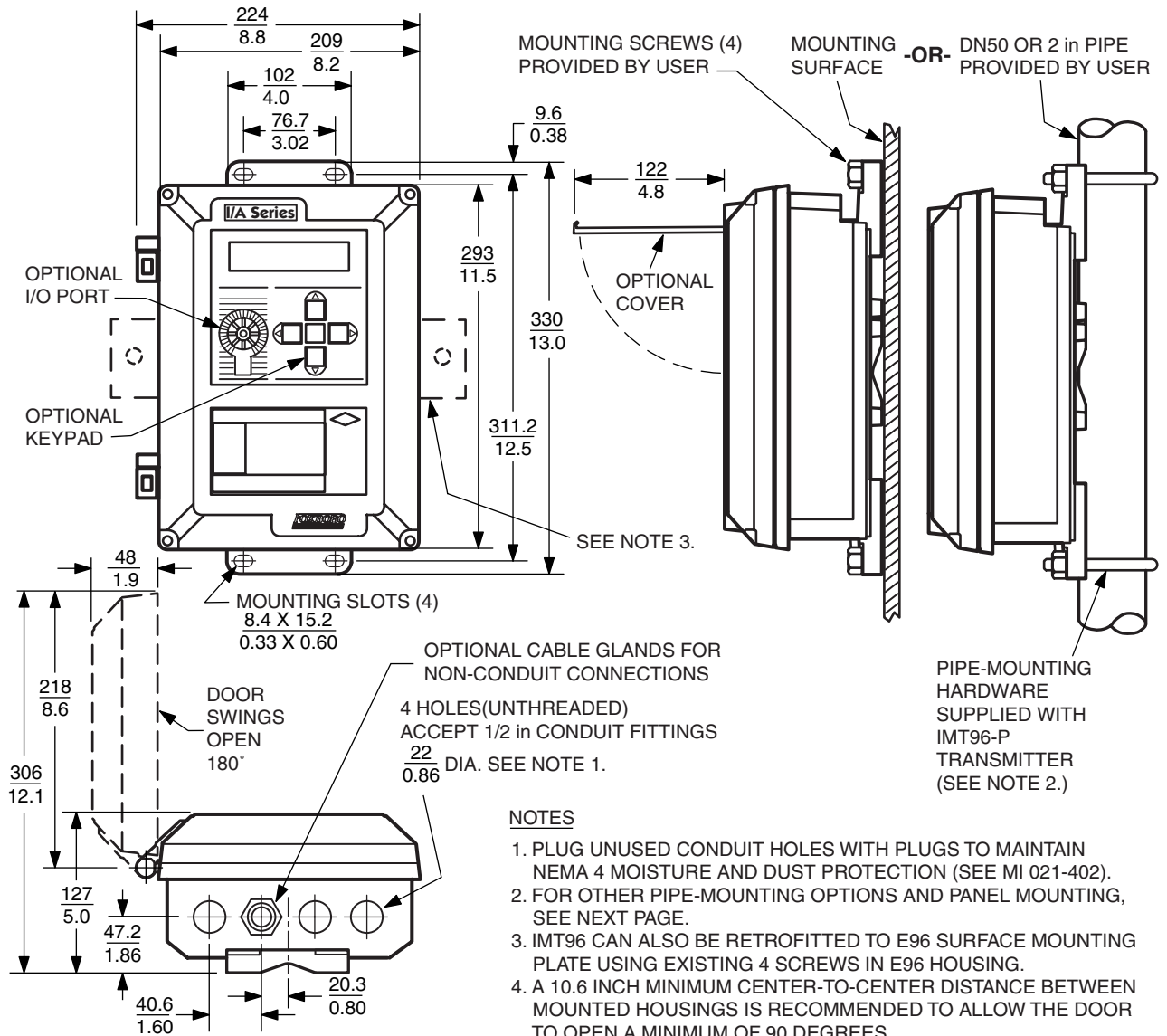

DIMENSIONS - NOMINAL (CONT.)

mm
in

MOUNTING TO VERTICAL HORN OR HORIZONTAL PIPE

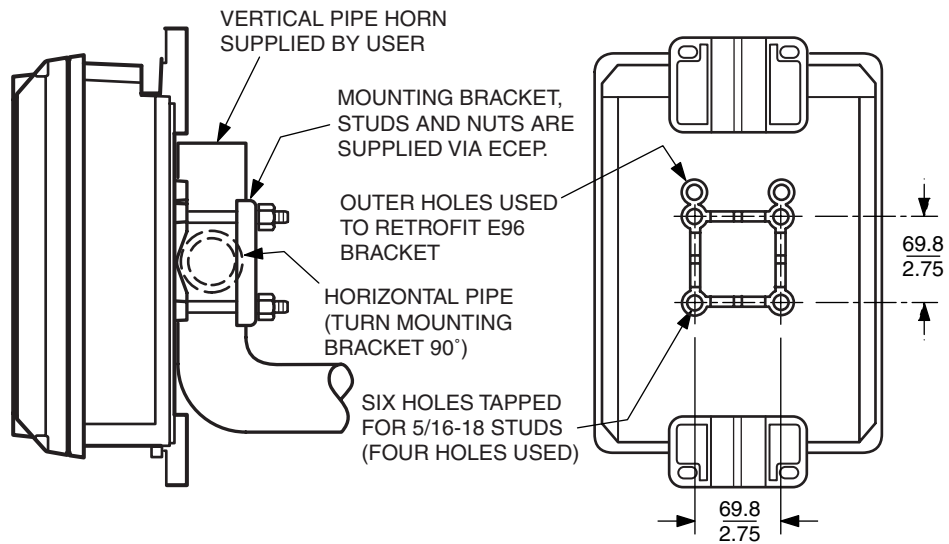

PANEL MOUNTING

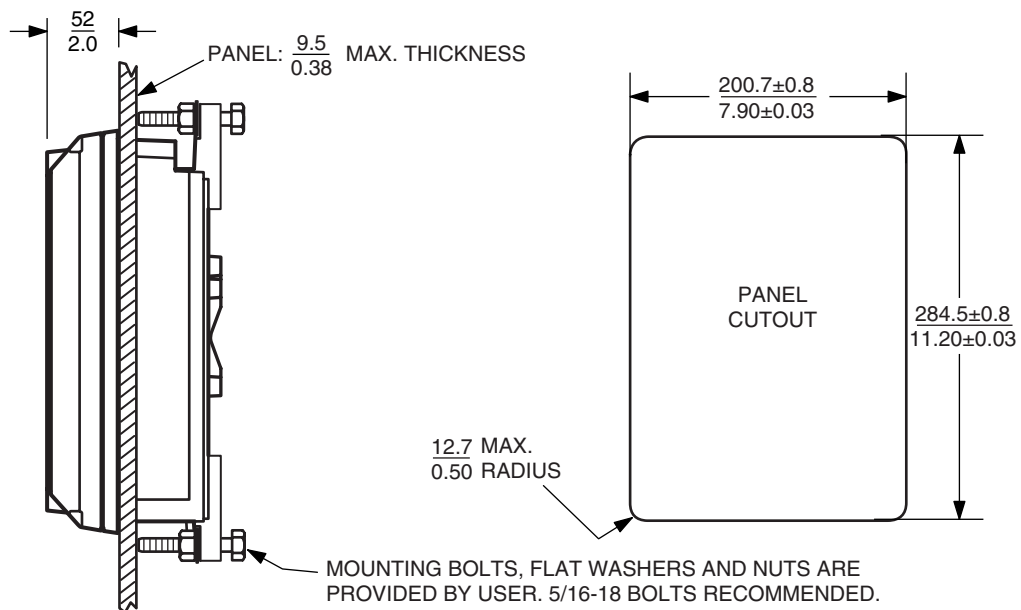

ORDERING INSTRUCTIONS

1. MagEXPERT (Model IMT96) Model Number
2. Signal Cable Part Number and Length (if necessary). See Signal Cable Length paragraphs in Functional Specifications section, and also Optional Selections and Accessories section.
3. User Tag Information

OTHER M&I PRODUCTS

IPS provides a broad range of measurement and instrument products, including solutions for pressure, flow, analytical, positioners, temperature, controlling and recording. For a listing of these offerings, visit the IPS web site at:

www.ips.invensys.com



IPS Corporate Headquarters
5601 Granite Parkway Suite 1000
Plano, TX 75024
www.ips.invensys.com

Foxboro Global Client Support
Inside U.S.: 1-866-746-6477
Outside U.S.: 1-508-549-2424 or contact
your local Foxboro representative.
Facsimile: 1-508-549-4999

Invensys, Foxboro, I/A Series, FoxCom, and
MagEXPERT are trademarks of Invensys plc, its
subsidiaries, and affiliates.
All other brand names may be trademarks of their
respective owners.

Copyright 1999-2009 Invensys Systems, Inc.
All rights reserved

MB 010 Printed in U.S.A.

0109