

9100A Series Magnetic Flowtubes with Neoprene or EPDM Liners 1 to 78 in (25 to 2000 mm) Nominal Flowtube Sizes



The 9100A Series Magnetic Flowtubes, together with an IMT25 Magnetic Flow Transmitter, combine to form a Magnetic Flowmeter with pulsed dc excitation. It is designed for use with conductive fluids in general purpose, and waste and water applications. The transmitter converts the low level, high impedance signal from the lined flowtube to a scaled transmission signal, either 4 to 20 mA, digital, or pulse output, that is proportional to volumetric flow rate.

FEATURES

- Reliability and Dynamic Range meet the Heavy Demands of the Water Treatment Industry
- Field-Proven Electrode Seal Design
- Choice of bonded Neoprene or EPDM Liner
- Enclosure meets IEC IP67 and NEMA Type 4X; Upgradeable to IEC IP68
- Withstands Temporary Flooding before, during, and after Installation; Can be upgraded on Site to withstand Continuous Flooding
- Each Flowtube has Built-in Grounding (Earthing) Electrodes
- Large Selection of Flowtube Sizes and Flanges
- Unidirectional or Bidirectional Flow
- Optional Liner Protector offered for Processes with High Velocity and Abrasive Fluids
- Conforms to Applicable European Union Directives (Product Marked with CE Logo)

SUPERIOR REPUTATION FOR DEPENDABILITY AND QUALITY

Foxboro introduced magnetic flow measurement systems to the process industries in 1954 and has demonstrated the broadest and most time-proven application expertise with tens of thousands of successful small and large size flowtube installations.

INTELLIGENT PATH TO MAG FLOW SYSTEMS

The merging of the latest technology in flowtube design, in conjunction with the Intelligent IMT25 Magnetic Flow Transmitter, provides the waste and water industries with a significant advancement in conductive liquid flow measurement. In addition to 4 to 20 mA and pulse output signals, remote digital communication is provided using either FoxCom, HART, or FOUNDATION fieldbus protocols.

PULSED DC FLOWTUBES USED WITH REMOTE MOUNTED TRANSMITTERS

The 9100A Series Magnetic Flowtubes are calibrated for use with pulsed dc coil excitation. As stated above, Foxboro offers the Intelligent I/A Series IMT25 Magnetic Flow Transmitter for use with these flowtubes. This transmitter may be remote mounted on a pipe or to a flat surface for distances up to 1000 ft (300 m) away from the flowtube.

LARGE SELECTION OF FLOWTUBE SIZES

Flowtubes are offered with a selection of sizes from 1 to 78 in or from DN 25 to DN 2000. Consistent with the size selected, ANSI Class 150, PN 6, PN 10, PN 16, PN 40, and AWWA⁽¹⁾ C-207 Class D flanges are provided as end connections.

WEATHERPROOF AND CORROSION RESISTANT CONSTRUCTION - SUBMERSIBLE FLOWTUBES

These flowtubes are designed to operate in harsh outdoor environments. The enclosure is weatherproof as defined by IEC IP67, and provides the watertight and corrosion resistant protection of NEMA Type 4X. The standard IEC IP67 flowtube can also withstand submersion at a 1.5 m (5 ft) depth for a period up to 72 hours. This depth can be increased to 10 m (33 ft) and continuous flooding by using a field submersion kit. Refer to the Optional Selections section.

EXCELLENT ZERO STABILITY

Excellent zero stability is inherent in the design. The mechanical design and electronic package feature accurately located and securely mounted coil and electrode assemblies, spring-loaded electrodes, optimized field characterization, and power-driven screens (shields) on the signal leads. All of these features ensure the ultimate in long-term stability, signal integrity, and accurate measurement.

STRAIGHT-THROUGH TUBE DESIGN

The straight-through, unobstructed tube design makes these flowtubes ideal for waste water and sludge fluids where a minimal pressure drop is required. This means lower fluid movement costs.

GROUNDING (EARTHING) ELECTRODES

The flowtube design incorporates built-in grounding electrodes as standard. This means that these flowtubes can be installed in metallic, nonmetallic, or lined pipelines without the need for grounding rings.

LINER PROTECTION

Optional liner protection is offered using grounding rings on the upstream side of the flowtube to mechanically protect the liner from high velocity and very abrasive fluids.

COMPACT FLOWTUBE

The 9100A flowtube has a compact design that provides face-to-face overall lengths in each size that conform to recommended flowtube dimensions contained in ISO/DIS 13359.

LOW POWER CONSUMPTION

All Flowmeter configurations are designed to consume less than 24 W of power at reference voltage and frequency.

FLOWTUBE CALIBRATION

All flowtubes are wet calibrated to verify their specified accuracy. The calibration facilities have been accredited to the EN 45001 standards.

CE COMPLIANCE

These flowtubes conform to the applicable European Community Standards when used in conjunction with the IMT25 Magnetic Flow Transmitter.

(1) AWWA = American Water Works Association.

OPERATING CONDITIONS

Influence	Reference Operating Conditions	Normal Operating Condition Limits
Ambient Temperature	20 ±2°C (68 ±3°F)	–40 and +100°C (–40 and +212°F)
Process Temperature	20 ±2°C (68 ±3°F)	with Neoprene Liner: 0 and 95°C (32 and 203°F) with EPDM Liner: –10 and +95°C (14 and 203°F)
Process Pressure	3 bar gauge (43 psig)	with Neoprene or EPDM Liners: Full Vacuum and Flange Rating
Vibration	Negligible	0 and 32 m/s ² (0 and 3.2 “g”) from 18 to 1000 Hz in all directions

PERFORMANCE SPECIFICATIONS

The Model 9100A Flowtube is used with I/A Series Magnetic Flow Transmitters to form a magnetic flow system. System performance specifications are listed in the following Magnetic Flow Transmitter PSSs.

- PSS 1-6F5 A IMT25 Magnetic Flow Transmitter with FoxCom or HART Communications Protocol
- PSS 1-6F5 B IMT 25 Magnetic Flow Transmitter with FOUNDATION Fieldbus Communication Protocol

FUNCTIONAL SPECIFICATIONS

Nominal Flowtube Sizes

1 to 78 in (DN 25 to DN 2000). Refer to Model Code section for a complete listing of flowtube sizes.

End Connections

ANSI, AWWA, and BS 4504 (DIN 2501) flanges. Refer to Model Code section for a listing of flange types and ratings available with each flowtube size.

Process Fluid Conductivity

The minimum process fluid conductivity required is 5 µS/cm. For empty pipe detection, the minimum process fluid conductivity is 20 µS/cm. Refer to TI 027-072 for conductivities of various process liquids. Also see Table 1.

Signal Cable Length

The maximum allowable cable length is a function of the cable type, process fluid conductivity, and whether the cables are in the same or separate conduits. Standard magnetic flow system accuracy is maintained when the installations are in accordance with Table 1.

Neoprene Liner

A Neoprene liner is the best choice when used with clean, mildly corrosive, or mildly abrasive fluids. It is not recommended when used with severe corrosive or severe abrasive fluids. Generally, Neoprene is selected for general purpose, sewage, drinking water, and district heating applications.

Maximum Cable Length	Minimum Fluid Conductivity	Signal and Coil Drive Cables
300 m (1000 ft)	5 µS/cm	Signal and coil drive cables in separate conduit. Signal Cable to be Foxboro Part No. R0101ZS (feet) or B4017TE (metres).
225 m (700 ft)	5 µS/cm	Signal and coil drive cables in same conduit. Signal Cable to be Foxboro Part No. R0101ZS (feet) or B4017TE (metres).
150 m (500 ft)	20 µS/cm	Signal cable may be in same conduit as coil drive cable. Signal cable to be good quality twisted shielded pair, preferable no smaller than 1.0 mm ² (or 18 AWG) for mechanical considerations (Belden 8760 or 9318, Alpha 5610/1801 or 5611/1801, or equivalent).

(a) Values in table are fluid conductivity minimums, and maximum distance between transmitter and flowtube. Refer to TI 027-072 for conductivities of various process liquids.

FUNCTIONAL SPECIFICATIONS (Cont.)

EPDM Liners (an Ethylene Propylene Terpolymer)

EPDM liners are also a recommended choice for clean, mildly abrasive fluids. Additionally, they are the preferred choice when used with more corrosive fluids. The Foxboro 9200A and 9300A Series Magnetic Flowtubes offer additional liners and electrodes for highly corrosive or abrasive applications. Refer to PSS 1-6F10 A and PSS 1-6F4 A respectively.

Flowtube Process Pressure-Temperature Limits

The maximum pressure limit of the flowtube is equal to the pressure limit of the flanges selected. The flowtube temperature limit depends on the liner material. See Figure 1 for Pressure-Temperature limits of Model 9100A Flowtubes.

The shaded area beneath each flange curve represents the flowtube pressure-temperature limits for each flange type with the selected liner. The vertical dashed lines represent the temperature limits of the Neoprene and EPDM liners. For example, looking at either the DIN or ANSI curve, Area A-B-C-D-A represents the process pressure-temperature limits of the flowtube with an EPDM liner and a PN 40 or ANSI Class 150 flange; and Area E-F-C-D-E represents the process pressure-temperature limits of the flowtube with a Neoprene liner and either a PN 40 or ANSI Class 150 carbon steel flange.

Also, as shown in Figure 1, for AWWA C207 Class D flanges, the pressure rating is 150 psig within the temperature limits of the liner.

Flow Velocity (Figures 2 and 3)

MINIMUM VELOCITY FLOW RANGE

0 to 1.65 ft/s (0 to 0.50 m/s)

MAXIMUM VELOCITY FLOW RANGE

0 to 33 ft/s (0 to 10 m/s)

RECOMMENDED OPERATING VELOCITY

General Liquids

3 to 15 ft/s (0.9 to 4.6 m/s)

Erosive Slurries

3 to 6 ft/s (0.9 to 1.8 m/s)

Liquids that Coat Flowtube Surface

6 to 15 ft/s (1.8 to 4.6 m/s)

Flow Rate (Figures 2 and 3)

Figures 2 and 3 show the relationship between volume flow rate, flow velocity, and flowtube size in metric and U.S. Customary units. Also see Table 1.

Table 1. Unit Conversion Factors

To Convert:	Multiply by:	To Obtain:
m ³ /h	16.67	L/min
m ³ /h	0.2778	L/s
m ³ /h	4.403	U.S. gpm
L/min	0.06	m ³ /h
L/min	0.0167	L/s
L/s	3.60	m ³ /h
L/s	60.0	L/min
U.S. gpm	0.8327	IMP gpm
U.S. gpm	8.021	ft ³ /h
U.S. gpm	0.2271	m ³ /h
U.S. gpm	60.0	U.S. gph
U.S. gph	0.0167	U.S. gpm
IMP gpm	1.201	U.S. gpm
ft ³ /h	0.1247	U.S. gpm

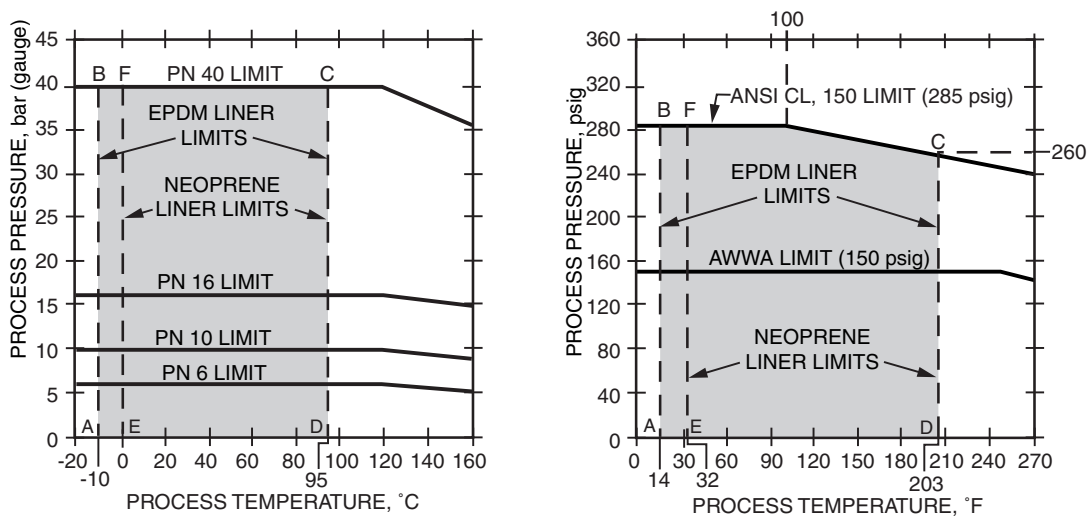

Figure 1. Flowtube Process Pressure-Temperature Limits with Various Liners, and ANSI/DIN Flanges

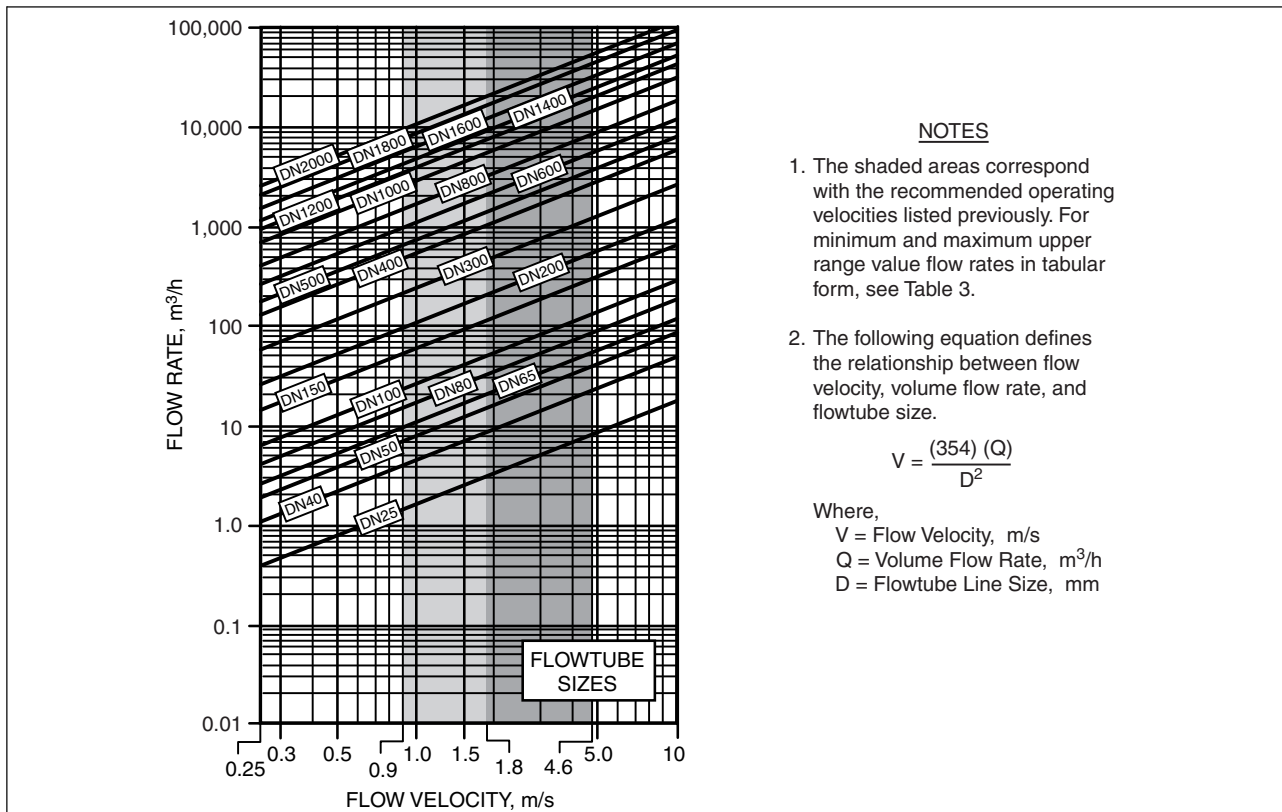

Figure 2. Flowtube Sizing Curves in Metric Units - Also See Table 3

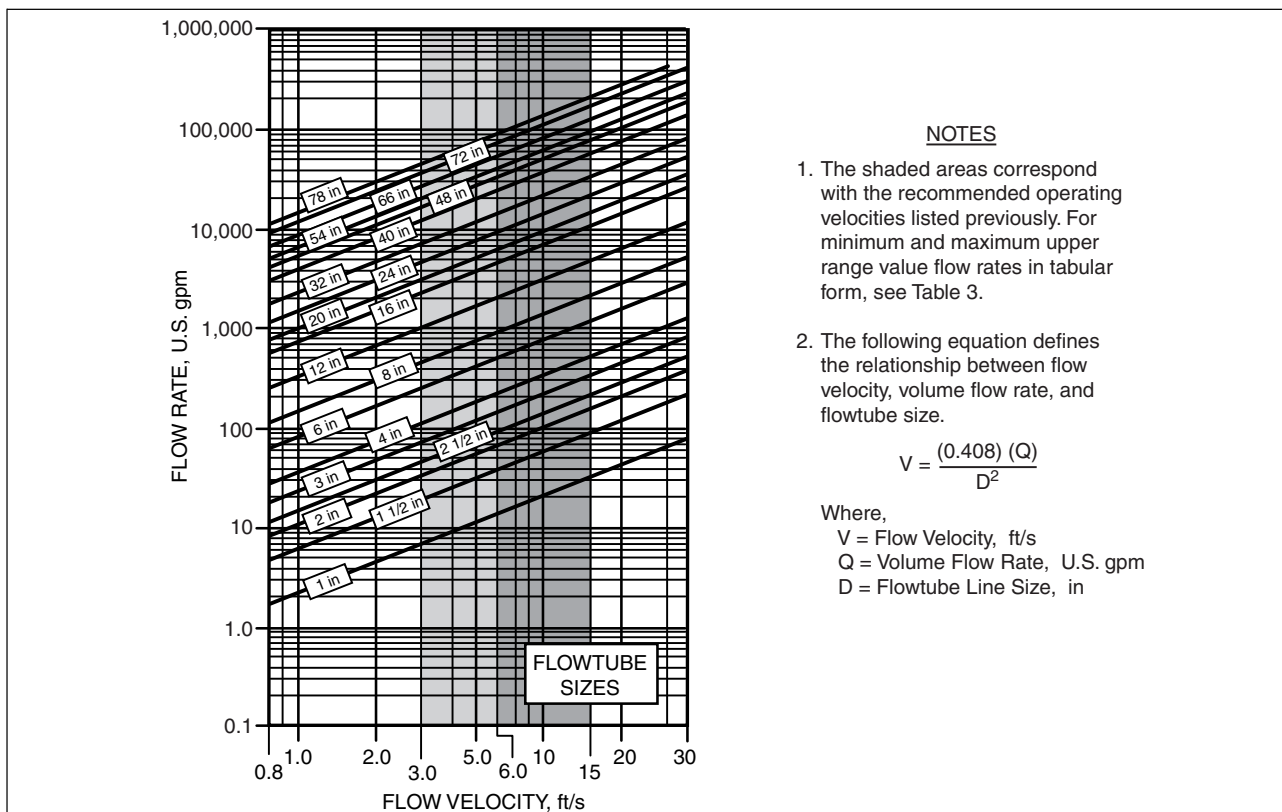

Figure 3. Flowtube Sizing Curves in U.S. Customary Units - Also See Table 3

FUNCTIONAL SPECIFICATIONS (Cont.)

Flowtube Size		Metric Units		U.S. Customary Units	
DN Flange Size	Inch Flange Size	Minimum URV(a)	Maximum URV(a)	Minimum URV(a)	Maximum URV(a)
DN 25	1 in	0.80 m ³ /h	16 m ³ /h	3.5 U.S. gpm	70 U.S. gpm
DN 40	1 1/2 in	2.1 m ³ /h	42 m ³ /h	9.0 U.S. gpm	180 U.S. gpm
DN 50	2 in	2.9 m ³ /h	58 m ³ /h	12.5 U.S. gpm	250 U.S. gpm
DN 65	2 1/2 in	5.0 m ³ /h	100 m ³ /h	22 U.S. gpm	440 U.S. gpm
DN 80	3 in	7.1 m ³ /h	142 m ³ /h	31 U.S. gpm	625 U.S. gpm
DN 100	4 in	12.0 m ³ /h	250 m ³ /h	55 U.S. gpm	1100 U.S. gpm
DN 125	5 in	19.3 m ³ /h	385 m ³ /h	85 U.S. gpm	1700 U.S. gpm
DN 150	6 in	27.7 m ³ /h	554 m ³ /h	122 U.S. gpm	2440 U.S. gpm
DN 200	8 in	58.0 m ³ /h	1160 m ³ /h	255 U.S. gpm	5100 U.S. gpm
DN 250	10 in	93.0 m ³ /h	1860 m ³ /h	410 U.S. gpm	8200 U.S. gpm
DN 300	12 in	133 m ³ /h	2660 m ³ /h	585 U.S. gpm	11 700 U.S. gpm
DN 350	14 in	165 m ³ /h	3300 m ³ /h	730 U.S. gpm	14 600 U.S. gpm
DN 400	16 in	220 m ³ /h	4400 m ³ /h	960 U.S. gpm	19 200 U.S. gpm
DN 450	18 in	280 m ³ /h	5600 m ³ /h	1200 U.S. gpm	24 000 U.S. gpm
DN 500	20 in	340 m ³ /h	6800 m ³ /h	1500 U.S. gpm	30 000 U.S. gpm
DN 600	24 in	490 m ³ /h	9800 m ³ /h	2150 U.S. gpm	43 000 U.S. gpm
DN 700	28 in	690 m ³ /h	13 800 m ³ /h	3000 U.S. gpm	60 000 U.S. gpm
–	30 in	–	–	3400 U.S. gpm	68 000 U.S. gpm
DN 800	32 in	900 m ³ /h	18 000 m ³ /h	3900 U.S. gpm	78 000 U.S. gpm
DN 900	36 in	1 150 m ³ /h	23 000 m ³ /h	5000 U.S. gpm	100 000 U.S. gpm
DN 1000	40 in	1400 m ³ /h	28 000 m ³ /h	6200 U.S. gpm	124 000 U.S. gpm
–	42 in	–	–	6800 U.S. gpm	136 000 U.S. gpm
–	44 in	–	–	7500 U.S. gpm	150 000 U.S. gpm
DN 1200	48 in	2050 m ³ /h	41 000 m ³ /h	9000 U.S. gpm	180 000 U.S. gpm
DN 1400	54 in	2800 m ³ /h	56 000 m ³ /h	12 000 U.S. gpm	240 000 U.S. gpm
–	60 in	–	–	14 000 U.S. gpm	280 000 U.S. gpm
DN 1600	66 in	4000 m ³ /h	80 000 m ³ /h	17 500 U.S. gpm	350 000 U.S. gpm
DN 1800	72 in	4800 m ³ /h	96 000 m ³ /h	21 000 U.S. gpm	420 000 U.S. gpm
DN 2000	78 in	5600 m ³ /h	112 000 m ³ /h	25 000 U.S. gpm	500 000 U.S. gpm

(a) URV = Upper range value. See Table 1 for unit conversions.

PHYSICAL SPECIFICATIONS

Flowtube Enclosure (Including Terminal Box)

The overall flowtube enclosure construction meets IEC IP67 and provides the environmental protection of NEMA Type 4X. When used with an optional submersion kit, the enclosure meets IP68 and NEMA Type 6. See Optional Selections section.

Housing Material

Carbon steel with corrosion-resistant, two component coating.

Flowtube Material

AISI Type 304 ss

Flange Material

Carbon Steel with corrosion resistant, two component coating.

Terminal Box Enclosure Material

Fiberglass reinforced polyamide, or aluminum, as specified.

Process Wetted Materials

FLOWTUBE LINER

Neoprene or EPDM, as specified.

ELECTRODES

AISI Type 316Ti ss

FLANGE GASKETS

Provided by user.

Electrical Connections

Four 1/2 NPT holes with cable glands for cable entry are provided on the plastic terminal box, and two 1/2 NPT holes for conduit are provided on the aluminum terminal box. Separate screw type terminals within the terminal box are provided for electrode and coil cable terminations. Refer to Dimensions - Nominal section.

Installation Requirements

During measurement, the flowtube must remain full with the process fluid to achieve the stated performance. Installation in a vertical pipe with flow going upward is ideal. For horizontal installations, position the flowtube so that the electrodes are in a horizontal plane. The minimum upstream straight pipe length recommended is five pipe diameters, and the minimum downstream straight pipe length recommended is three pipe diameters. The pipe length is measured outward from the center of the flowtube. Refer to the applicable installation instructions for more details.

Approximate Mass

Nominal Flowtube Size		Approximate Mass(a)	
DN Flange Size	Inch Flange Size	kg	lb
DN 25	1 in	5	11
DN 40	1 1/2 in	8	17
DN 50	2 in	9	20
DN 65	2 1/2 in	11	24
DN 80	3 in	12	26
DN 100	4 in	16	35
DN 125	5 in	19	42
DN 150	6 in	27	59
DN 200	8 in	40	88
DN 250	10 in	60	130
DN 300	12 in	80	176
DN 350	14 in	110	242
DN 400	16 in	125	275
DN 450	18 in	175	385
DN 500	20 in	200	440
DN 600	24 in	300	660
DN 700	28 in	350	770
–	30 in	–	909
DN 800	32 in	475	1045
DN 900	36 in	560	1232
DN 1000	40 in	700	1540
–	42 in	–	1600
–	44 in	–	2145
DN 1200	48 in	1250	2750
DN 1400	54 in	1753	3857
–	60 in	–	4503
DN 1600	66 in	2341	5150
DN 1800	72 in	3253	7157
DN 2000	78 in	4060	8932

(a) Approximate Mass using metric flanges and including the plastic terminal box. Pound (lb) weights are converted from the kg weights and are rounded upward to the next whole number.

ELECTRICAL SAFETY SPECIFICATIONS

Testing Laboratory, Types of Protection, and Area Classification	Application Conditions	Electrical Safety Design Code
FM - General purpose (ordinary) locations	—	M
FM nonincendive Class I, Division 2, Groups A, B, C, and D hazardous locations.	Temperature Class T4; Ta = 100°C.	N
No Approval or Certification Required; Flowtube marked with CE logo.	—	Z

NOTE

Flowtubes have been designed to meet electrical safety descriptions listed above. For detailed information, or status of testing laboratory approvals or certifications, contact Invensys Foxboro.

OPTIONAL SELECTIONS AND ACCESSORIES

Submersion Kit to IEC IP68

The standard flowtube enclosure meets IEC IP67 and may be immersed in water. A submersion kit option is offered to field upgrade the protection from IEC IP67 to IEC IP68. The table below compares the standard submersion protection, and improved protection using the optional submersion kit. Specify Part Number 085U0220 for the optional IP68 Submersion Kit.

Designation	Submersion Depth	Submersion Duration
IP67; NEMA 4X (Standard)	1.5 m Water (5 ft Water)	72 hours
IP68; NEMA 6 (Optional)	10 m Water (33 ft Water)	Continuous

Low Voltage Electrode Cleaning Assembly (Voltage Boil-off Procedure)

The low voltage electrode cleaning assembly provides a convenient means of applying a low voltage to the electrodes, while simultaneously protecting the transmitter by short-circuiting the signal input. The low voltage and current remove sludge or film deposits from the electrodes so that the system continues normal, accurate operation. This assembly is for indoor use only, and not to be used in “hose down” environments. Supply voltage is 120 V ac, 50 to 60 Hz, and the flowtube must be in ordinary locations. This assembly is available for all flowtube sizes. Specify Part No. D0128JW.

Liner Protection

A Type C 304 ss liner protection ring is offered for the Neoprene and EPDM lined flowtubes to provide liner protection against high velocity and/or very abrasive fluids. The ring is installed on the upstream end of the flowtube. See Table 4 for ring size and approximate mass, and see Table 5 for ring part numbers. The 9100A flowtube does not require grounding rings to provide accurate flow measurements.

OPTIONAL SELECTIONS AND ACCESSORIES (Cont.)

Flowtube Size		Type C Liner Protection Ring - 304 ss						Liner Protection Ring Configuration
DN Flange Size	Inch Flange Size	Dim. T1		Dim. T2		Approx. Mass		
		mm	in	mm	in	kg	lb	
DN 25	1 in	1.2	0.047	15	0.59	0.03	0.07	
DN 40	1 1/2 in	1.2	0.047	15	0.59	0.08	0.18	
DN 50	2 in	1.2	0.047	15	0.59	0.12	0.26	
DN 65	2 1/2 in	1.2	0.047	15	0.59	0.16	0.35	
DN 80	3 in	1.2	0.047	15	0.59	0.20	0.44	
DN 100	4 in	1.2	0.047	15	0.59	0.25	0.55	
DN 125	5 in	1.2	0.047	15	0.59	0.29	0.64	
DN 150	6 in	1.2	0.047	15	0.59	0.33	0.73	
DN 200	8 in	1.2	0.047	15	0.59	0.37	0.81	
DN 250	10 in	1.2	0.047	15	0.59	0.4	0.88	
DN 300	12 in	1.6	0.063	20	0.79	0.6	1.3	
DN 350	14 in	1.6	0.063	20	0.79	1.0	2.2	
DN 400	16 in	1.6	0.063	20	0.79	1.4	3.1	
DN 450	18 in	1.6	0.063	20	0.79	1.8	4.0	
DN 500	20 in	1.6	0.063	20	0.79	2.2	4.8	
DN 600	24 in	1.6	0.063	20	0.79	2.6	5.7	
DN 700	28 in	2.0	0.079	25	0.98	3.0	6.6	
-	30 in	2.0	0.079	25	0.98	3.3	7.3	
DN 800	32 in	2.0	0.079	25	0.98	3.7	8.1	
DN 900	36 in	2.0	0.079	25	0.98	4.0	8.8	
DN 1000	40 in	2.0	0.079	25	0.98	4.4	9.7	
-	42 in	2.0	0.079	25	0.98	4.5	10.0	
-	44 in	2.0	0.079	25	0.98	4.7	10.3	
DN 1200	48 in	2.0	0.079	25	0.98	5.0	11.0	
DN 1400	54 in	3.0	0.12	40	1.6	9.0	20	
-	60 in	3.0	0.12	40	1.6	10.0	24	
DN 1600	66 in	3.0	0.12	40	1.6	12.5	28	
DN 1800	72 in	3.0	0.12	40	1.6	14.3	32	
DN 2000	78 in	3.0	0.12	40	1.6	16	35	

(a) Type C 304 ss ring is used with both Neoprene and EPDM lined flowtubes for liner protection. Rings are not needed for fluid reference ground since the flowtube includes grounding electrodes.

OPTIONAL SELECTIONS AND ACCESSORIES (Cont.)

Nominal Flowtube Size		Part Number for Liner Protection Ring for Each Flange Type - 304 ss					
		DIN PN 6	DIN PN 10	DIN PN 16	DIN PN 40	ANSI Cl. 150	AWWA C-207
DN 25	1 in	–	–	–	083N8361	083N8361	–
DN 40	1 1/2 in	–	–	–	083N8362	083N8362	–
DN 50	2 in	–	–	–	083N8344	083N8344	–
DN 65	2 1/2 in	–	–	083N8345	–	083N8345	–
DN 80	3 in	–	–	083N8347	–	083N8347	–
DN 100	4 in	–	–	083N8025	–	083N8025	–
DN 125	5 in	–	–	083N8071	–	083N8071	–
DN 150	6 in	–	–	083N8008	–	083N8008	–
DN 200	8 in	–	083N8011	083N8011	–	083N8011	–
DN 250	10 in	–	083N8013	083N8013	–	083N8013	–
DN 300	12 in	–	083N8012	083N8012	–	083N8012	–
DN 350	14 in	–	083N8039	083N8039	–	083N8039	–
DN 400	16 in	–	083N8100	083N8100	–	083N8100	–
DN 450	18 in	–	083N8103	083N8104	–	083N8104	–
DN 500	20 in	–	083N8107	083N8108	–	083N8107	–
DN 600	24 in	–	083N8111	083N8112	–	083N8113	–
DN 700	28 in	–	083N8294	083N8294	–	–	(a)
–	30 in	–	–	–	–	–	(a)
DN 800	32 in	–	083N8304	083N8304	–	–	(a)
DN 900	36 in	–	083N8307	083N8307	–	–	(a)
DN 1000	40 in	–	083N8310	083N8310	–	–	(a)
–	42 in	–	–	–	–	–	(a)
–	44 in	–	–	–	–	–	(a)
DN 1200	48 in	–	083N8313	083N8313	–	–	(a)
DN 1400	54 in	083N8349	083N8353	083N8357	–	–	(a)
–	60 in	–	–	–	–	–	(a)
DN 1600	66 in	083N8350	083N8354	083N8358	–	–	(a)
DN 1800	72 in	083N8351	083N8355	083N8359	–	–	(a)
DN 2000	78 in	083N8352	083N8356	083N8360	–	–	(a)

(a) Contact Invensys Foxboro.

MODEL CODE

9100A Series Magnetic Flowtubes

Nominal Flowtube Size (a)		Model
DN Flange Size	Inch Flange Size	
DN 25	1 in	9101A
DN 40	1 1/2 in	911HA
DN 50	2 in	9102A
DN 65	2 1/2 in	912HA
DN 80	3 in	9103A
DN 100	4 in	9104A
DN 125	5 in	9105A
DN 150	6 in	9106A
DN 200	8 in	9108A
DN 250	10 in	9110A
DN 300	12 in	9112A
DN 350	14 in	9114A
DN 400	16 in	9116A
DN 450	18 in	9118A
DN 500	20 in	9120A
DN 600	24 in	9124A
DN 700	28 in	9128A
–	30 in	9130A
DN 800	32 in	9132A
DN 900	36 in	9136A
DN 1000	40 in	9140A
–	42 in (42 inch AWWA Flange on a 40 inch Tube)	9142A
–	44 in	9144A
DN 1200	48 in	9148A
DN 1400	54 in (54 inch AWWA Flange on a 56 inch Tube)	9154A
–	60 in	9160A
DN 1600	66 in (66 inch AWWA Flange on a 64 inch Tube)	9166A
DN 1800	72 in	9172A
DN 2000	78 in (78 inch AWWA Flange on a 80 inch Tube)	9178A
Tube Construction		
AISI Type 304 Stainless Steel Tube (304 ss)		–SI
End Connections		
ANSI Class 150, Carbon Steel Flange - 1 to 24 in Line Sizes		BA
AWWA C-207, Class D, Carbon Steel Flange - 28 to 78 in Line Sizes		WB
PN 6, DIN 2501, Carbon Steel Flange - DN 1400 to DN 2000 Line Sizes		ZZ
PN 10, DIN 2501, Carbon Steel Flange - DN 200 to DN 2000 Line Sizes		ZD
PN 16, DIN 2501, Carbon Steel Flange - DN 65 to DN 2000 Line Sizes		ZE
PN 40, DIN 2501, Carbon Steel Flange - DN 25 to DN 50 Line Sizes		ZG

MODEL CODE CONTINUED ON NEXT PAGE

MODEL CODE (Cont.)

9100A Series Magnetic Flowtubes (Cont.)

<p><u>Liner Material</u> Neoprene EPDM (an Ethylene Propylene Terpolymer)</p> <p><u>Electrodes</u> AISI Type 316Ti Stainless Steel (316Ti ss) - Fluid Reference Electrode Included</p> <p><u>Coil Drive</u> Pulsed dc</p> <p><u>Housing Construction/Transmitter Mounting</u> Coated Carbon Steel Housing with Aluminum Terminal Box – Terminal Box has two 1/2 NPT Conduit Threads – Remote Mounted Transmitter Coated Carbon Steel Housing with Polyamide Terminal Box – Terminal Box has four 1/2 NPT Threads with Cable Glands – Remote Mounted Transmitter</p> <p><u>Electrical Safety (Also see Electrical Safety Specifications section)</u> FM, General Purpose (Ordinary) Locations FM, Nonincendive, Class I, Division 2 No Approvals - Flowtube Marked with “CE” Logo</p> <p>Example: 9116A-SIBA-ESJ-GM</p>	<p>–N –E</p> <p>S</p> <p>J</p> <p>–G –F</p> <p>M N Z</p>
--	--

(a) See “End Connection” selections further in Code to determine ANSI, AWWA, and BS (DIN) flanges applicable to each flowtube size.

DIMENSIONS - NOMINAL

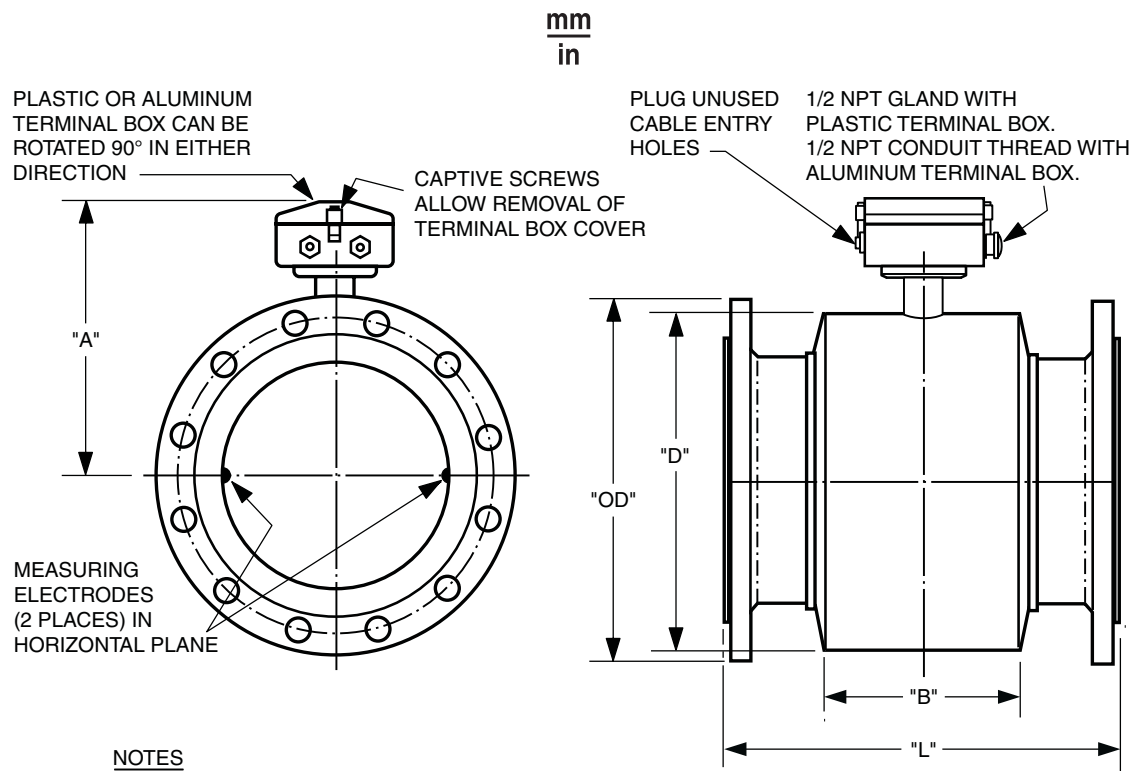

NOTES

1. SEE TABLE THAT FOLLOWS FOR FLOWTUBE DIMENSIONS. FLANGE "OD" AND NUMBER OF FLANGE BOLT HOLES ARE PER THE APPLICABLE FLANGE STANDARDS.
2. IN THE FIGURES ABOVE, THE PLASTIC TERMINAL BOX IS SHOWN. THE ALUMINUM TERMINAL BOX HAS A SLIGHTLY DIFFERENT CONFIGURATION AND SIZE.
3. THE PLASTIC TERMINAL BOX IS PROVIDED WITH FOUR 1/2 NPT THREADED HOLES WITH CABLE GLANDS. THE ALUMINUM TERMINAL BOX IS PROVIDED WITH TWO 1/2 NPT THREADED HOLES FOR CONDUIT.
4. THE BUILT-IN GROUNDING (EARTHING) ELECTRODES ARE NOT SHOWN. THEY ARE LOCATED BELOW THE MEASURING ELECTRODES SHOWN IN THE FIGURE ABOVE.

DIMENSIONS - NOMINAL (Cont.)

Flowtube Size		Nominal Dimensions											
DN Flange Size	Inch Flange Size	Dim. A (a)		Dim. B		Dim. D		Dimension L for Flange Type(b)					
		mm	in	mm	in	mm	in	PN 6 mm	PN 10 mm	PN 16 mm	PN 40 mm	Cl. 150 in	AWWA in
DN 25	1 in	187	7.4	59	2.3	104	4.1	–	–	–	<u>200</u>	<u>7.87</u>	–
DN 40	1 1/2 in	197	7.8	82	3.2	124	4.9	–	–	–	<u>200</u>	<u>7.87</u>	–
DN 50	2 in	205	8.1	72	2.8	139	5.5	–	–	–	<u>200</u>	<u>7.87</u>	–
DN 65	2 1/2 in	212	8.3	72	2.8	154	6.1	–	–	<u>200</u>	–	<u>7.87</u>	–
DN 80	3 in	222	8.7	72	2.8	174	6.9	–	–	<u>200</u>	–	10.7	–
DN 100	4 in	242	9.5	85	3.3	214	8.4	–	–	<u>250</u>	–	<u>9.84</u>	–
DN 125	5 in	255	10.0	85	3.3	239	9.4	–	–	<u>250</u>	–	<u>9.84</u>	–
DN 150	6 in	276	10.9	85	3.3	282	11.1	–	–	<u>300</u>	–	<u>11.81</u>	–
DN 200	8 in	304	12.0	137	5.4	338	13.3	–	<u>350</u>	<u>350</u>	–	<u>13.8</u>	–
DN 250	10 in	332	13.1	137	5.4	393	15.5	–	<u>450</u>	<u>450</u>	–	<u>17.7</u>	–
DN 300	12 in	357	14.1	137	5.4	444	17.5	–	<u>500</u>	<u>500</u>	–	<u>19.7</u>	–
DN 350	14 in	362	14.3	270	10.6	451	17.8	–	<u>550</u>	<u>550</u>	–	<u>21.7</u>	–
DN 400	16 in	387	15.2	270	10.6	502	19.8	–	<u>600</u>	<u>600</u>	–	<u>23.6</u>	–
DN 450	18 in	418	16.5	310	12.2	563	22.2	–	600	600	–	23.6	–
DN 500	20 in	443	17.4	350	13.8	614	24.2	–	<u>625</u>	<u>625</u>	–	26.8	–
DN 600	24 in	494	19.4	430	16.9	715	28.1	–	750	750	–	32.3	–
DN 700	28 in	544	21.4	500	19.7	816	32.1	–	<u>875</u>	<u>875</u>	–	–	34.5
–	30 in	571	22.5	556	21.9	869	34.2	–	–	–	–	–	36.9
DN 800	32 in	606	23.9	560	22.0	927	36.5	–	<u>1000</u>	<u>1000</u>	–	–	39.4
DN 900	36 in	653	25.7	630	24.8	1032	40.6	–	<u>1125</u>	<u>1125</u>	–	–	44.3
DN 1000	40 in	704	27.7	670	26.4	1136	44.7	–	<u>1250</u>	<u>1250</u>	–	–	49.2
–	42 in	704	27.7	670	26.4	1136	44.7	–	–	–	–	–	49.2
–	44 in	755	29.7	770	30.3	1238	48.7	–	–	–	–	–	54.1
DN 1200	48 in	810	31.9	792	31.2	1348	53.1	–	<u>1500</u>	<u>1500</u>	–	–	59.1
DN 1400	54 in	925	36.4	1000	39.4	1675	65.9	<u>1750</u>	<u>1750</u>	<u>1750</u>	–	–	68.9
–	60 in	972	38.3	1020	40.2	1672	65.8	–	–	–	–	–	73.8
DN 1600	66 in	1025	40.4	1130	44.5	1915	75.4	<u>2000</u>	<u>2000</u>	<u>2000</u>	–	–	78.7
DN 1800	72 in	1123	44.2	1250	49.2	1974	77.7	<u>2250</u>	–	–	–	–	88.5
DN 2000	78 in	1223	48.1	1375	54.1	2174	85.6	<u>2500</u>	<u>2500</u>	<u>2500</u>	–	–	98.4

(a) Dimension "A" is for a flowtube with the plastic terminal box. This dimension is reduced by approximately 30 mm (1.2 in) when the aluminum terminal box is used.

(b) Underlined length dimensions (Dimension "L") comply with ISO/DIS Standard 13359.

ORDERING INSTRUCTIONS

1. Model Number
2. Operating Flow Range (Also see Figures 2 and 3, and Table 3)
3. Process Pressure-Temperature Range
4. Process Fluid Composition and Conductivity (Also see Table 1)
5. Options or Accessories - See Options and Accessories Section for Descriptions and Ordering Instructions.
6. User Tag Data

OTHER M&I PRODUCTS

Invensys Foxboro provides a broad range of measurement and instrument products, including solutions for pressure, flow, analytical, positioners, temperature, controlling and recording. For a listing of these offerings, visit the Invensys Foxboro web site at:

www.foxboro.com/instrumentation

33 Commercial Street
Foxboro, MA 02035-2099
United States of America
www.foxboro.com
Inside U.S.: 1-866-746-6477
Outside U.S.: 1-508-549-2424
or contact your local Foxboro
representative.
Facsimile: 1-508-549-4999

Invensys, Foxboro, d/p Cell, FoxCom, and I/A Series are trademarks of Invensys plc, its subsidiaries, and affiliates.
All other brand names may be trademarks of their respective owners.

Copyright 2001-2007 Invensys Systems, Inc.
All rights reserved

MB 010

Printed in U.S.A.

0507