

Model 875EC Intelligent Electrochemical Analyzer for Electrodeless Conductivity Measurement

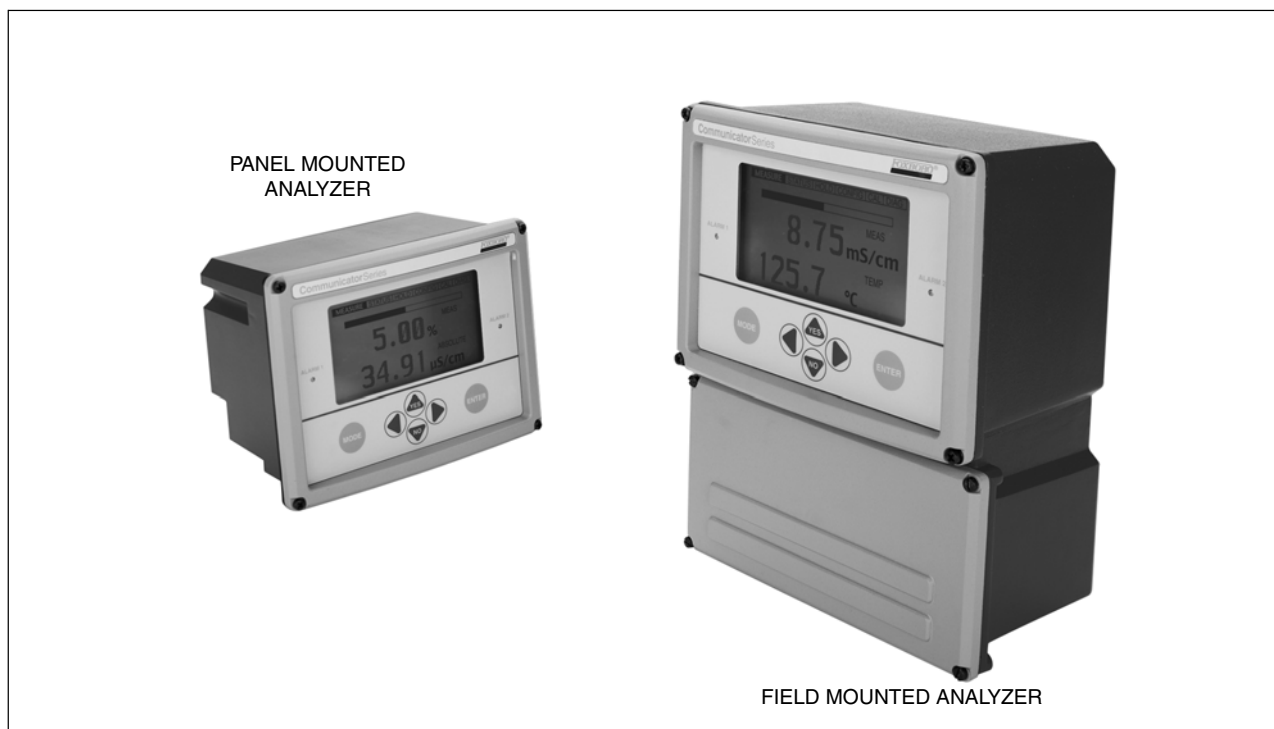

This microprocessor-based, line-powered intelligent analyzer, when used with Foxboro 871EC or 871FT sensors, provides high accuracy measurement for electrodeless conductivity. Functions include measurement display, dual analog outputs, dual relay contacts, and an RS-232 Serial Port for remote configuration. A human interface guides the user through intuitive, menu-driven configuration, calibration, status, and troubleshooting procedures.

FEATURES

- Easy to Use.
- Conductivity or concentration measurement.
- Optional HART Communication Protocol.
- Designed with your industry in mind.
- High Sensitivity, Wide Rangeability.
- RS-232 Port and Windows-based Configuration Utility.
- Application switching and storage of up to 3 sets of application configurations.
- Remote range and application switching using plc compatible contact inputs.
- Ease of sensor configuration.
- Dual Alarms and Dual 4 to 20 mA Outputs.
- Chemical concentration control.
- History Log for up to 100 events.
- Remote auto-service for sensor cleaning and calibration.
- NEMA 4X and IEC IP65 protection for field mounted analyzer, and for front surface of panel mounted analyzer.
- On-Line sensor and analyzer diagnostics communicate real-time measurement faults.
- Secure data and calibrations.
- Complies with EMC Directive 89-336-EEC.
- Conforms to all applicable European Union Directives (Product Marked with "CE" Logo).

EASY TO USE

The Model 875EC Intelligent Electrochemical Analyzer provides fast and simple installation, configuration, and operation. Input and output wiring is easily accessible. On the field-mounted version, all wiring terminals are accessible through a removable, front-facing cover. On the panel-mounted version, wiring terminals are directly accessible from the rear of the analyzer without removing any covers.

A large, backlit Liquid Crystal Display (LCD) with intuitive menu navigation and on-screen help makes configuration easy and less prone to error. Users have a choice of either **basic** or **advanced** configuration, depending on their needs. **Basic** configuration provides access to only the most commonly changed parameters, greatly simplifying the procedure. **Advanced** configuration, which is protected by a different passcode than **basic**, allows for complete configuration by authorized personnel. Prior to accepting a new configuration, the analyzer performs complete parameter dependency checking, and informs the user of any conflicting or offending parameters. The analyzer then brings the user to the parameter(s) in question, and prompts the user to review the selection(s) that should be altered.

Calibration routines are also intuitive and menu-driven. Users are offered a choice of bench or solution calibration routines, depending on user preference.

For the ultimate in ease of use, the analyzer is available with an optional Windows-based PC configuration utility that utilizes the standard RS-232 serial communication port. More information on this feature is located further in this document.

CONDUCTIVITY OR CONCENTRATION MEASUREMENT

This analyzer can be configured to measure in either conductivity units such as $\mu\text{S}/\text{cm}$ or mS/cm , or one of a host of chemical concentration units such as percent (%), grams per liter (g/L), parts per million (ppm), parts per thousand (ppt), and ounces per gallon (oz/gal). A series of preprogrammed temperature and percent chemical concentration curves is available as a standard feature. User programmable curves may also be used for special applications such as uncommon chemicals, proprietary processes, or nonbinary solutions.

EASE OF SENSOR CONFIGURATION

Foxboro is the world leader in electrodeless conductivity sensor technology and product breadth. Foxboro offers both insertion/submersion sensors, the 871EC Series, and revolutionary flow-through sensors, the 871FT Series. Both lines of sensors are offered in a multitude of sizes, materials, geometries, and mounting configurations to satisfy the majority of applications in process industries. Different sensor form factors and construction techniques result in different sensor cell factors, which affect the sensitivity and range of a particular conductivity loop.

To simplify the sensor compatibility process, the analyzer provides menu selections for each type of 871EC and 871FT sensor, as well as a user-programmable cell factor for optimization of special sensors (such as Foxboro EP402 flow-through and EP307 glass and thermoplastic versions). In addition, a selection of three different temperature compensator inputs (100 ohm platinum RTD, 1000 ohm platinum RTD, and 100 kohm thermistor), ensures compatibility with standard temperature sensors, high temperature sensors, and sensors of a specialized nature. Refer to Figure 1 for 871FT Flow-Through Sensors and 871EC Series Sensors. Also refer to PSS 6-3Q1 A and PSS 6-3C4 A, respectively, for further sensor specifications

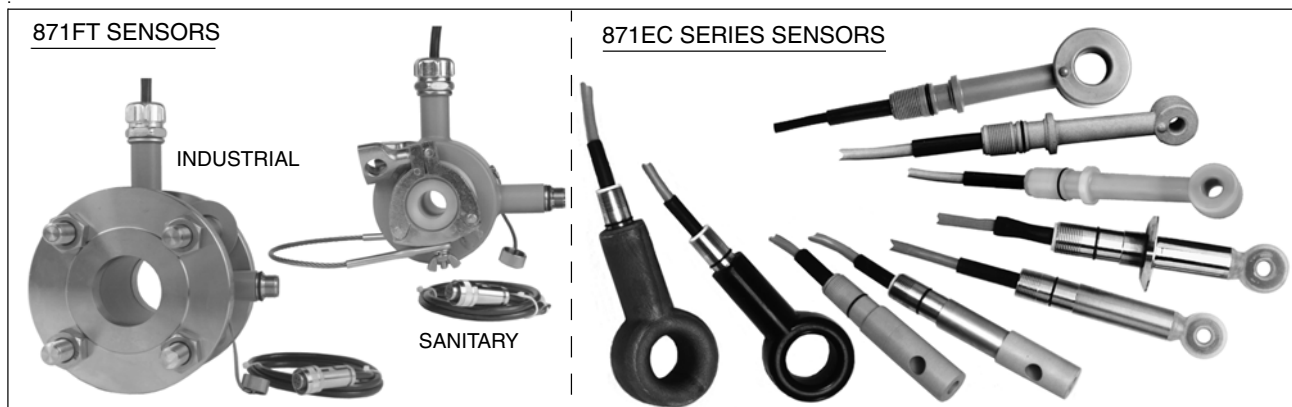

Figure 1. 871EC and 871FT Sensors

DESIGNED WITH YOUR INDUSTRY IN MIND

Foxboro's long history in electrodeless conductivity measurement has resulted in a comprehensive array of chemical concentration and temperature compensation transforms. These standard curves can be employed to optimize critical measurements in several common end user segments. Here are just a few examples of industry applications.

Pulp and Paper Industry Applications

- Dissolving Tank (Green Liquor) and Digester Alkali (Black Liquor) Temperature Compensation Curves
- White Liquor Concentration Control

Chemical Industry Applications

- Standard Concentration Curves for Common Electrolytes, as follows:
 - Acids: Sulfuric, Nitric, Hydrochloric, Phosphoric, Hydrofluoric, Acetic
 - Bases: Caustic, Potassium Hydroxide
 - Salts: Sodium Chloride, Potassium Chloride

Power Industry Applications

- Demineralization, Regeneration, and Concentration Control of Sodium Hydroxide and Sulfuric Acid

Food and Beverage Industry Applications

- Clean-In-Place (CIP) using Standard Caustic and Acid Curves
- Sodium Hydroxide Concentration Control for Pretzel Blanching
- Brine Density Control for Pea Grading

Metals and Mining Industry Applications

- Steel Pickling Bath Concentration Control

Semiconductor Industry Applications

- Acid Etching Solution Concentration Control

In all, Foxboro offers 17 standard chemical concentration ranges, and 22 temperature compensation types. And in the event your application is not covered, Foxboro readily shares data from its application files to help you develop custom curves to optimize your conductivity measurement.

CUSTOMIZE AND EMPLOY UP TO THREE APPLICATIONS

This unique feature allows the user to preconfigure the analyzer for up to three distinct applications. Each application may have its own range, temperature compensation curve, chemical concentration curve (if applicable), and output configuration. Each application is assigned a number, for example, application 1, application 2, or application 3. If the user wishes to switch from one application to another, the user simply changes one parameter in the configuration menu and the entire application set switches in automatically. This is a powerful feature for users who frequently change among a handful of common recipes.

In many cases, the user will want the analyzer to auto-switch from one application to another without user intervention. This can be accomplished in two ways, either through auto-switching based on predetermined switch points, or through a command from an external host (e.g., PLC) to a series of digital inputs, each dedicated to a specific application set. Each method of auto-switching is described below.

Auto-Switching Using Switch Limits

User-programmable switch limits determine when the analyzer auto-switches from application 1 to application 2, then again from application 2 to application 3. Similarly, the analyzer auto-switches in a descending fashion depending on the low switch point programmed by the user.

Auto-Switching Using Digital Inputs

Each 875EC Analyzer provides 4 digital inputs, 3 of which are dedicated to application sets – input 1 for application 1, input 2 for application 2, etc. If a PLC is controlling a particular process (Clean-In-Place for beverage, dairy, etc., for example), the user can program the PLC to command the 875EC to switch to a specific application based on time or process control parameters such as temperature, concentration, conductivity, etc.

Because each of the applications (three maximum) is individually configured, calibration constants are stored in memory and invoked as the application is retrieved. Thus, the analyzer can switch from a wide range conductivity application to a very sensitive one without the need to recalibrate the system for the new range. This results in tremendous time savings for operators, and eliminates common sources of error in critical applications.

CHOICE OF DIGITAL COMMUNICATIONS

The 875EC Analyzer provides maximum flexibility of digital communications. The basic instrument, with two printed wiring assemblies (PWAs), provides two analog outputs and a built-in RS-232 serial port. For users who require digital communication, a third (optional) PWA for HART communication protocol provides connection between the analyzer and host. This PWA can be installed in the basic analyzer, or can be installed in the field at a later time.

The optional HART PWA contains nonvolatile memory, which allows the module to store its unique communication configuration parameters. Functions available via the digital communication option include:

- View Measurement Data
- View Analyzer Status Data
- Perform Analyzer Configuration
- Upload and Download Configuration Data
- Perform System Calibration
- View Sensor and Analyzer Diagnostics
- Place the Analyzer on Hold

HIGH SENSITIVITY, WIDE RANGEABILITY

Using patented Foxboro sensor technology, the analyzer delivers a high sensitivity conductivity solution for applications such as steam condensate or boiler blowdown. Ranges as low as 50 $\mu\text{S}/\text{cm}$ can be accommodated. However, the analyzer is also capable of measuring as high as 2000 mS/cm with numerous intermediate range choices, thus assuring full compatibility with all applications.

RS-232 PORT AND WINDOWS-BASED CONFIGURATION UTILITY

Every 875EC Analyzer is manufactured with a built-in RS-232 port. This non-isolated port can be connected to simple printers and terminals for continuous display of measurement data.

When used with the optional Windows-based configuration utility, the instrument can be addressed from a standard PC, providing easy implementation of the following functions:

- View Measurement Data
- View Analyzer Status Data
- Perform Analyzer Configuration
- Upload Configuration Data from Analyzer
- Download Configuration Data to Analyzer
- Perform System Calibration
- View Sensor and Analyzer Diagnostics
- Place the Analyzer on Hold
- Download Firmware to Analyzer

The RS-232 port is user configurable for baud rate, update time, data and parity, and stop bits.

DUAL ALARMS AND DUAL 4 to 20 mA OUTPUTS

Two independent, isolated alarm relays are standard. Either alarm is configurable as **off** (nonfunctional) or **on**. When **on**, the alarm is configurable to go **active** (energize relay) or **inactive** (de-energize relay) while either passing above or below a measurement set point. Each alarm may also be programmed for either hysteresis control, or control based on timing for trigger (delay), on, and off. Two front-panel LEDs indicate when in alarm.

There are also two independent, isolated 4 to 20 mA analog outputs that are standard. When the optional HART communications PWA is installed, the standard output #2 becomes disabled, and the HART output becomes the second analog output.

The alarms and outputs are each configurable to any of the following parameters:

- Temperature Compensated Conductivity
- Absolute Conductivity
- Temperature
- Chemical Concentration

Additionally, the alarms can be configured to “trip” based on:

- Analyzer in Hold
- Analyzer Fault, Communication Fault, Sensor Fault, Out-of-Range Fault
- Sensor Auto-Service Engaged

HISTORY LOG

End users' compliance to ISO⁽¹⁾, GMP⁽¹⁾, and other quality and validation systems are enhanced by the Model 875EC's history log function.

The history log contains up to 100 time and date stamped reported errors, faults, and system-related events. Examples of entries in the history log are:

- Entry Into and Exit From Configuration, Calibration and Hold Modes
- Changes to Configuration, Calibration, and Hold
- Analyzer Power Restored after Outage
- Passcode Changed
- Application Switch
- Alarm 1 or Alarm 2 Activated
- Errors Temporarily Cleared
- Sensor Faults
- Analyzer Faults

Contents of the history log can be printed on demand by utilizing the standard RS-232 port.

(1) ISO = International Standards Organization; GMP = Good Manufacturing Practice.

MOUNTING FOR EITHER FIELD OR PANEL APPLICATIONS

Foxboro offers two distinct analyzer housings to best meet your application needs.

For **field mounted** (surface or pipe mounting) use, the analyzer is housed in a tough, epoxy-painted cast aluminum enclosure able to withstand the harshest field conditions. This enclosure provides the environmental and corrosion-resistant protection of NEMA 4X, CSA Enclosure 4X, and IEC IP65. All input/output wiring is accessible from the front of the instrument through a dedicated field compartment. The terminal connections within this compartment are accessed by simply removing a front cover.

For **panel mounted** applications, a molded plastic enclosure with minimal depth behind the user's panel, saves space, is light weight, and reduces cost. Direct access (no cover) to the wiring terminals is from the rear of the instrument. This version is rated NEMA 1; however, the front panel meets NEMA 4X requirements when attached to the user's panel, and gasketed in place with the Foxboro-supplied gasket.

Both field and panel mounted units have large spade lug terminals for sensor connections to facilitate installation, calibration, and maintenance. Either unit can also be provided with an optional Plexiglas storm door to prevent accidental activation of the front panel controls, and for dust and hose-down protection. See "Dimensions-Nominal" section for mounting and dimensional information.

SENSOR AND ANALYZER DIAGNOSTICS

When used with Foxboro 871EC or 871FT Sensors, the analyzer provides sensor diagnostics, including liquid leakage into the sensor body and failure of the temperature compensation element.

In addition, the analyzer performs continuous health checks on its own circuits. Firmware diagnostics include checksum and EEPROM on power-up, code space checksum and CRC on power-up (and approximately every five minutes thereafter), and continuous stack checking and watchdog timer.

For additional information about the specific fault(s), the user need only access the "DIAG" menu and follow the prompts. This procedure not only identifies specific faults, but also guides the user to corrective action without referring to an instruction book.

CHEMICAL CONCENTRATION CONTROL

On/off control of chemical concentration can be accomplished with the 875EC by using alarms with feed and delay timers. Noncontacting sensors provide reliable chemical concentration measurement, saving money by minimizing chemical waste.

SECURE DATA AND CALIBRATIONS

Three security levels guard against unauthorized configuration/calibration changes, loss of data, and/or invalid measurement signals. The first passcode permits access to routine maintenance, including calibration and basic output hold. The second passcode permits changes to all first level parameters, plus advanced output hold and basic configuration. The third passcode permits changes to all second level parameters, plus advanced configuration and all passcode changes.

Data stored in EEPROM obviates need for battery backup. Measurement loop security is enhanced by a user programmable "fail signal" parameter activated by analyzer faults and any enabled sensor faults. This "fail signal" parameter forces the analyzer output to any user-defined value between 3.8 and 20.5 mA.

HUMAN INTERFACE

The local Human Interface allows configuration, calibration, status, and fault location without the need of a hand-held terminal. This interface consists of MODE Indicators, a 2-line Display area, a Bargraph Display, two Alarm Indicators, MODE and ENTER keys, LEFT and RIGHT arrow keys, and UP and DOWN arrow keys. The backlit measurement display characters are 15 mm (0.6 in) high to allow easy reading from a distance. See Table 1 for a description of the indicators and controls, and Figure 2 for the Human Interface configuration.

The display area shown in Figure 2, in addition to indicating measurement data, is also used to display different screens. Figures 3 and 4 show the display area with a Configuration and Status screen, respectively.

Table 1. Human Interface Indicators and Controls (Also see Figure 2)

Control/Indicator	Function
MODE Indicators	The current operating mode indicator is illuminated. While in Hold mode, the Hold indicator blinks.
DISPLAY Area <ul style="list-style-type: none"> • Bargraph • Line 1 • Line 2 	The display is a graphic panel that shows information in combinations of alphanumeric and special characters, and a decimal point. <ul style="list-style-type: none"> • Displays percent-of-range of the Line 1 value on the display. • Displays measurements in Measure mode. • Displays measurements in Measure mode.
ALARM Indicators	Alarm 1 (Alarm 2) indicator is illuminated when Alarm 1 (Alarm 2) is active.
MODE Key	Each press of the Mode key selects the next operating mode (Measure, Status, Hold, Calibrate, Configure, and Diagnostic).
RIGHT Arrow Key	<ul style="list-style-type: none"> • Moves you forward through the menu structure. • Shifts the cursor to the right in a data entry field. • Offers a “short cut” to the Alarm 2 set point when in Measure mode.
LEFT Arrow Key	<ul style="list-style-type: none"> • Moves you backward through the menu structure. • Shifts the cursor to the left in a data entry field. • Offers a “short cut” to the Alarm 1 set point when in Measure mode.
UP Arrow Key	<ul style="list-style-type: none"> • Increments a numeric value or character when in a data entry field. • Shifts the items down when in a picklist menu. • Answers Yes to a question.
DOWN Arrow Key	<ul style="list-style-type: none"> • Decrements a numeric value or character when in a data entry field. • Shifts the items up when in a picklist menu. • Answers No to a question.
ENTER Key	Enters and saves the changed menu picklist choices or numeric value or character data entry.

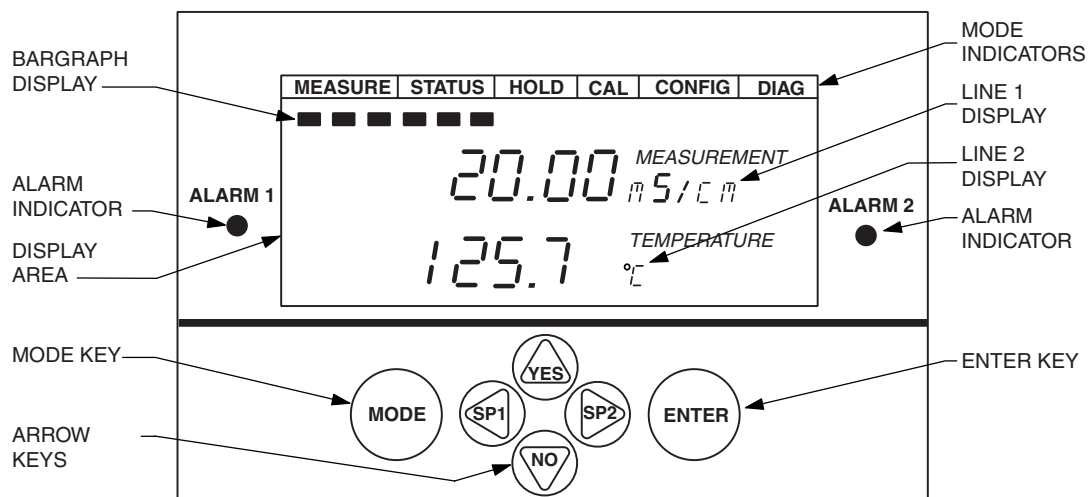

Figure 2. Human Interface Layout

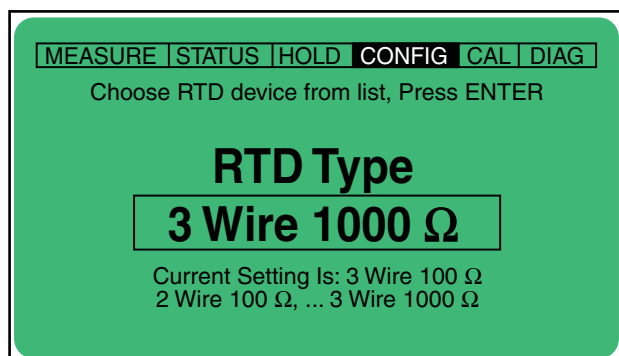

Figure 3. Configuration Screen

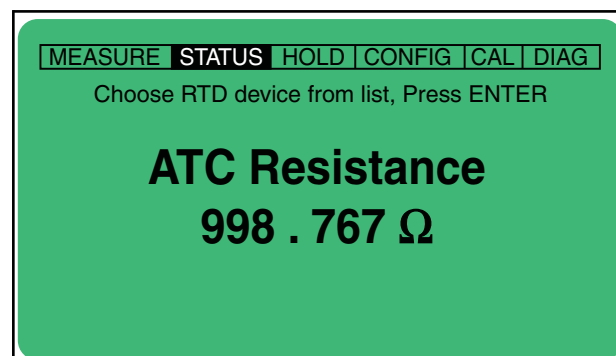

Figure 4. Status Screen

OPERATING, STORAGE, AND TRANSPORTATION CONDITIONS

Influence	Reference Operating Conditions	Normal Operating Conditions	Operative Limits	Storage and Transportation Limits
Ambient Temperature	23 ±2°C (73 ±4°F)	-10 to + 65°C (a) (14 to 149°F)	-20 and +75°C (a) (-4 and +165°F)	-40 and +85°C (-40 and +185°F)
Relative Humidity	50 ±10%	5 to 95% Noncondensing	5 and 95% Noncondensing	5 and 95% Noncondensing
Supply Voltage, ac (b)	Rated Voltage ±1%	Rated Voltage -15 to +10%	Rated Voltage -20 and +15%	Not Applicable
Supply Frequency, ac	50 or 60 Hz, ±1%	50 or 60 Hz, ±3 Hz	50 and 60 Hz, ±3 Hz	Not Applicable
Supply Voltage, dc	24 V dc, ±1%	19.2 to 33.6 V dc	18 to 36 V dc	Not Applicable
Vibration - Standard Construction • Field Mount • Panel Mount	<ul style="list-style-type: none"> • 1 “g” (10 m/s²) between a frequency of 5 and 200 Hz • 0.25 “g” (2.5 m/s²) between a frequency of 5 and 200 Hz 			Note (c)
Vibration - (d) Rugged Construction	Vibration qualified per MIL Std. 167-1 for use as a Navy shipboard device.			Note (c)
Mechanical Shock - (d) Rugged Construction	Mechanical shock qualified per MIL Std. S-901; Grade A, Class I, Type C, for use as a Navy shipboard device.			Note (c)
Pollution Degree	3, per ANSI/ISA S82.01			Not Applicable
Installation Category (Overvoltage Category)	II, per ANSI/ISA S82.01			Not Applicable
Mounting Position	Generally Upright	Any Position	Any Position	Not Applicable

(a) Refer to the Electrical Safety Specifications section for a restriction in ambient temperature with certain electrical certifications.

(b) Rated Voltage is 24, 100, 120, 220, or 240 V ac, 50 or 60 Hz. See Model Code section.

(c) During transportation, the packaged Analyzer can withstand normal handling and shipping conditions without damage.

(d) Rugged construction is only available with Field Mount Analyzers.

PERFORMANCE SPECIFICATIONS

(Analyzer Specifications under Reference Operating Conditions unless otherwise specified.
Refer to Sensor Literature for Sensor Specifications.)

Accuracy - Digital Output

±0.5% of full scale

Accuracy - Analog Output

Digital accuracy ±0.05% of full scale

Accuracy - Temperature (Includes Repeatability)

Sensor Description	Accuracy
2-wire, 100 Ω Plat. RTD(a)	±0.2°C (±0.36°F)
2-wire, 100 kΩ Thermistor(a)	±0.2°C (±0.36°F)
3-wire, 1000 Ω Plat. RTD	±0.1°C (±0.18°F)

(a) 2-wire platinum RTD and 100 kΩ thermistor have been corrected for cable length.

Repeatability

±0.1% of full scale

Stability

PRIMARY MEASUREMENT

±0.25% of full scale (temperature-compensated and after six months)

TEMPERATURE MEASUREMENT

±0.1% of full scale (noncumulative and after six months)

Response Time

PRIMARY MEASUREMENT

3 seconds or better, depending on configuration

TEMPERATURE MEASUREMENT

<10 seconds, 2- or 3-wire temperature sensor

Output Noise (Analog Outputs)

±0.25% of full scale (measured with a 500 Hz bandwidth)

Power Supply Effect

±0.5% of span for a +10% voltage shift.

±0.75% of span for a -15% voltage shift.

±0.1% of span for a 3 Hz shift at 50 or 60 Hz

Output Load Effect

<0.05% of span value. Effect is on output for a change of loop resistance of up to 800 Ω

Relative Humidity Effect

DIGITAL MEASUREMENT

±0.5% of span, from 50 to 95% RH at 40°C (104°F)

ANALOG OUTPUT

±0.5% of span, from 50 to 95% RH at 40°C (104°F)

Vibration Effect (Sensor not included)

Less than 0.1% of span

Ambient Temperature Effect

DIGITAL MEASUREMENT

±0.05% of span per °C

ANALOG OUTPUT

±0.05% of span per °C

Mounting Position Effect

Less than 0.01% of span for all positions.

European Union and International Directives

- Complies with Electromagnetic Compatibility Requirements of European EMC Directive 89/336/EEC by conforming to the following CENELEC and IEC Standards: EN 50081-2, EN 50082-2, and IEC 61000-4-2 through 61000-4-6.
- Complies with NAMUR Part 1 Interference Immunity Requirement (EMC).
- Conforms to Applicable European Union Directives ("CE" marking on product).

RFI Immunity⁽¹⁾

Output error of < 5% of full scale when tested with field strength of 10 V/m from 80 to 1000 MHz with 80% amplitude modulation at 1 kHz (IEC 61000-4-3).

RFI Emission⁽¹⁾

30 to 1000 MHz with 47 dB (µV/m) at 10 m (EN 50081-2)

CFI Immunity⁽¹⁾

10 V (rms) from 0.15 to 80 MHz with 80% amplitude modulation at 1 kHz (IEC 61000-4-6).

CFI Emission⁽¹⁾

0.15 to 30 MHz and 73 dB (µV) QP (EN 50081-2).

High Frequency Transient⁽¹⁾

Withstands high frequency transient on ac power line of +/-2 kV, 5 kHz and 5 nS rise time pulses (IEC 61000-4-4).

Lightning Transient⁽¹⁾

Withstands surge discharge of +/-4 kV with Tr/Th of 1.2/50 µS (IEC 61000-4-5).

Electrostatic Discharge⁽¹⁾

6 kV contact 8 kV air discharge, Criteria A (IEC 61000-4-2).

(1) All input/output cables must be installed in metallic conduit. Panel mount unit must be installed in metallic enclosure.

PERFORMANCE SPECIFICATIONS (Cont.)

Magnetic Field Immunity

30 A (rms)/m at 50/60 Hz (IEC 61000-4-8)(2).

Voltage Dips (ac Power Port)

10 ms at -30% Criteria B and 100 ms at -60% Criteria C (IEC 61000-4-11).

Voltage Interruptions (ac Power Port)

>95% at 5 s, Criteria C (IEC 61000-4-11).

Voltage Fluctuations (ac Power Port)

230 V ac +/-10% and 50 Hz +/-5%, 15 min (IEC SC77A WG6)

Common Mode Rejection Ratio

120 dB, dc; or 50/60 Hz, ac; between loop and sensor (42 V peak maximum)

FUNCTIONAL SPECIFICATIONS

Power Requirements

24, 100, 120, 220, or 240 V ac, 50 or 60 Hz; or 24 V dc.

Power Consumption

17 W maximum

Temperature Measurement Ranges

100 Ω PLATINUM RTD (2 WIRE)
-20 to +200°C (-4 to +392°F)
1000 Ω PLATINUM RTD (3 WIRE)
-20 to +200°C (-4 to +392°F)
100 kΩ THERMISTOR (2 WIRE)
-20 to +120°C (-4 to +248°F)

Temperature Compensations

Description	Reference	Range
Absolute	–	–
Dilute NaCl	25°C	0 to 200°C
0 to 25% NaCl	25°C	0 to 200°C
0 to 35% H ₃ PO ₄	25°C	4 to 93°C
0 to 15% HCl	25°C	-10 to +122°C
0 to 25% H ₂ SO ₄	25°C	-10 to +120°C
99.5 to 93% H ₂ SO ₄	50°C	-10 to +120°C
99.5 to 93% H ₂ SO ₄	30°C	20 to 90°C
42 to 18% Oleum	65°C	32 to 120°C
0 to 10% Oleum	65°C	32 to 120°C
0 to 10% HNO ₃	25°C	-10 to +120°C
0 to 15% NaOH	25°C	0 to 120°C
0 to 15% NaOH	50°C	0 to 100°C
0 to 20% NaOH	100°C	-11 to +122°C
0 to 6% KOH	25°C	10 to 40°C
0 to 16% KCl	20°C	0 to 25°C
0 to 8% CH ₃ COOH	25°C	4 to 120°C
0 to 30% HF	25°C	0 to 50°C
90 to 99% HF	0°C	-20 to +208°C
Kraft Green Liquor	85°C	35 to 95°C
Kraft Black Liquor	160°C	100 to 175°C
Linear TC Gain	25°C	0.5 to 5%/°C
Custom	–	–

Sensor Compatibility

- 871EC and 871FT Series Sensors
- 871EC Older Model Types PN, PX, and AB
- A Single Sensor may be connected to the Analyzer
- EP307 Series Sensors

Conductivity Measurement Ranges

Refer to Tables 2 and 4.

Percent (%) Concentration Measurement Range

Refer to Tables 3 and 4.

Analog Outputs

- Dual Isolated Outputs
- Outputs Configurable to:
 - Temperature Compensated Conductivity
 - Absolute Conductivity
 - Temperature
 - Chemical Concentration
- 4 to 20 mA Linear Output
- Analog Output Hold - from 3.8 to 20.5 mA
- Loop Power to support up to 800 Ω of Loop Resistance
- Analog Output Zero Setting adjustable to 100% of Full Scale Range. Minimum Difference of 5% between Zero and span Ranges
- Analog Output Programmable to any Value between 3.8 and 20.5 mA, upon failure

Analog Output Isolation

Outputs are isolated from earth (ground) and from each other.

Minimum Output Span (Measurement)

5% of full scale

Maximum Output Span (Measurement)

500% of full scale

Isolated Output Load

800 Ω maximum

FUNCTIONAL SPECIFICATIONS (Cont.)
Standard Digital Communications

RS-232C digital communications port for remote configuration and calibration via a user's PC. Configurator utility software is recommended for use with the PC (see Optional Features section).

Optional Digital Communications

HART Communication Protocol.

Digital Inputs

For PLC based control, 3 digital inputs are standard, each corresponding to a specific application (#1, #2, #3) configured in the analyzer. Each application may have unique range, units, outputs, temperature compensation, and alarms. Remote range switching can thus be controlled by a PLC for applications where the sensor will encounter fluids of varying conductivity levels (e.g., low, medium, high conductivity).

Specifications for Digital Inputs/Outputs

- Terminal DV+ power: 4.5 V \pm 3% at 10 mA max.
 - Terminal DV- power: -20 V \pm 1.0% at 10 mA max.
- Above voltages are provided by the 875 analyzer
- Digital Inputs 1 through 4
 - High Logic: User must ensure voltage to be between 2.7 and 10 V
 - Low Logic: User must ensure circuit to be open, or less than 0.8 V
 - Digital inputs are only to be used with the +4.5 V/-20 V outputs provided by the Foxboro 875 analyzer.

Contact Foxboro for sample wiring schemes.

Alarms

Two configurable alarms can be independently set as high or low alarms based on the primary measurement, input temperature, or a diagnostic. Each alarm is configurable for the following:

- Temperature Compensated Conductivity
- Absolute Conductivity
- Temperature
- Chemical Concentration
- Diagnostic Fault, Freely Programmable
- Initiate Sensor Auto-Service Cycle

Adjustable hysteresis for both alarms is 0 to 100% of full scale. Feed, delay, and trigger times are adjustable from 0 to 99.99 minutes.

Alarm Outputs

Mechanical Relay – Two independent, isolated, Form "C" contacts rated 2 A at 30 V dc, 5 A at 250 V ac noninductive. With ATEX and IEC certifications, the ratings are 2 A at 30 V dc and 5 A at 160 V ac. Inductive loads, such as a motor or solenoid, can be driven with external surge absorbing devices across contact terminations. Contacts are not powered by the 875 analyzer.

Displayed Data

Each of the two lines of the display area can be configured to present:

- Temperature Compensated Conductivity
- Absolute Conductivity
- Temperature
- Chemical Concentration
- Analog Output Channel 1 or 2
- Scan Mode - any of the above parameters at adjustable viewing cycles

Measurement Display Units

μ S/cm, mS/cm, mS/m, S/m, °C, °F, mA, g/L, oz/gal, ppt (parts per thousand), and ppm (parts per million)

Measurement Damping

Adjustable to None, 5, 10, 20, 40, or 120 seconds, where None is analyzer base response time.

Data Storage

Configuration, calibration, and operating parameters stored in nonvolatile memory for >5 years.

Operating Modes

- On-Line Measurement – Continuously outputs measurement data to front panel display and serial communication port
- On-Line Status – Provides current information
- Off-Line Calibration – Ability to calibrate analyzer full scale for primary measurements and temperature
- Off-Line Configuration – User can configure all ranges, units of measure, alarms, analog outputs, and other parameters
- Hold

Background Self-Diagnostics**ANALYZER**

- Checksum and EEPROM on Power Up
- Code Space Checksum and CRC on Power Up, and approximately every 5 minutes thereafter
- Stack Checking - Continuous
- Watchdog Timer - Continuous

SENSOR

- Automatic Temperature Compensator Open
- Automatic Temperature Compensator Short
- Liquid Leakage into Sensor

OTHER

- 4 to 20 mA Output Out-of-Range
- Temperature Compensation Out-of-Range
- Measurement Out-of-Range

FUNCTIONAL SPECIFICATIONS (Cont.)

Logbook Function (Also see Previous “History Log” Section)

Events such as warning messages, calibrations, and configuration activity stored in nonvolatile memory. Time-of-day and date stamped with each stored event. Storage accommodates 100 events.

Firmware Download

Analyzer’s operating firmware is downloadable to Analyzer via the RS-232 serial communication port using a utility executed on the user’s PC. See Model Code Optional Selection “-F”, Windows-based Configurator Utility Software.

Table 2. Conductivity Ranges For 871EC Sensors

mS/cm	–	0.1	0.2	0.5	1	2	5	10	20	50	100	200	500	1000	2000
µS/cm	50	100	200	500	1000	2000	5000	–	–	–	–	–	–	–	–
mS/m	5	10	20	50	100	200	500	1000	2000	5000	–	–	–	–	–
S/m	–	–	–	–	–	–	–	–	–	–	0.1	0.2	0.5	1	2
871EC-SP					X	X	X	X	X	X	X	X	X	X	X
871EC-PP					X	X	X	X	X	X	X	X	X	X	X
871EC-HP					X	X	X	X	X	X	X	X	X	X	X
871EC-LB	X	X	X	X	X	X	X	X	X	X	X	X			
871EC-UT	X	X	X	X	X	X	X	X	X	X	X	X			
871EC-RE			X	X	X	X	X	X	X	X	X	X	X	X	
871EC-BW			X	X	X	X	X	X	X	X	X	X	X	X	
871EC-NL					X	X	X	X	X	X	X	X	X	X	X
871EC-TF					X	X	X	X	X	X	X	X	X	X	X
871EC-EV			X	X	X	X	X	X	X	X	X	X	X	X	
871EC-AB			X	X	X	X	X	X	X	X	X	X	X	X	
871EC-PN					X	X	X	X	X	X	X	X	X	X	X
871EC-PX					X	X	X	X	X	X	X	X	X	X	X

Table 3. Percent (%) Concentration Ranges for 871EC Sensors (See Notes a and b)

Percent Conc.	NaCl 0-25%	H ₃ PO ₄ 0-35%	HCl 0-15%	H ₂ SO ₄ 99.5-93%	H ₂ SO ₄ 0-25%	Oleum 42-18%	Oleum 0-10%	HNO ₃ 0-10%	NaOH 0-15%	NaOH 0-20%	KOH 0-6%	KCl 0-16%	CH ₃ COOH 0-8%
871EC-SP	X	X	X		X			X	X	X	X	X	X
871EC-PP	X	X	X		X			X	X	X	X	X	X
871EC-HP	X	X	X		X			X	X	X	X	X	X
871EC-LB													X
871EC-UT													X
871EC-RE	X	X	X		X			X	X	X	X	X	X
871EC-BW	X	X	X		X			X	X	X	X	X	X
871EC-NL												X	
871EC-TF				X		X	X		X		X	X	
871EC-EV	X								X		X	X	
871EC-AB	X								X			X	
871EC-PN	X												
871EC-PX	X												

(a) Concentration ranges are determined by sensor material compatibility, not electronic limitations in analyzer.

(b) For other concentration ranges, contact Foxboro.

FUNCTIONAL SPECIFICATIONS (Cont.)

Table 4. Conductivity Ranges For 871FT English Flow-Through Sensors
(See Note below for % Concentration Ranges)

mS/cm	-	0.1	0.2	0.5	1	2	5	10	20	50	100	200	500	1000	2000	
µS/cm	50	100	200	500	1000	2000	5000	-	-	-	-	-	-	-	-	
mS/m	5	10	20	50	100	200	500	1000	2000	5000	-	-	-	-	-	
S/m	-	-	-	-	-	-	-	-	-	-	0.1	0.2	0.5	1	2	
871FT-1C						X	X	X	X	X	X	X	X	X	X	X
871FT-2C					X	X	X	X	X	X	X	X	X	X	X	X
871FT-1D					X	X	X	X	X	X	X	X	X	X	X	X
871FT-2D				X	X	X	X	X	X	X	X	X	X	X	X	
871FT-1E				X	X	X	X	X	X	X	X	X	X	X	X	X
871FT-2E			X	X	X	X	X	X	X	X	X	X	X	X	X	
871FT-1F			X	X	X	X	X	X	X	X	X	X	X	X	X	
871FT-2F		X	X	X	X	X	X	X	X	X	X	X	X	X		
871FT-1G		X	X	X	X	X	X	X	X	X	X	X	X	X		
871FT-2G	X	X	X	X	X	X	X	X	X	X	X	X	X			
871FT-1H	X	X	X	X	X	X	X	X	X	X	X	X	X			
871FT-2H	X	X	X	X	X	X	X	X	X	X	X	X	X			
871FT-1J	X	X	X	X	X	X	X	X	X	X	X	X	X			
871FT-2J	X	X	X	X	X	X	X	X	X	X						
871FT-3C					X	X	X	X	X	X	X	X	X	X	X	X
871FT-3E				X	X	X	X	X	X	X	X	X	X	X	X	X
871FT-4C			X	X	X	X	X	X	X	X	X	X	X	X	X	
871FT-4E		X	X	X	X	X	X	X	X	X	X	X	X			
871FT-3F			X	X	X	X	X	X	X	X	X	X	X	X	X	
871FT-4F	X	X	X	X	X	X	X	X	X	X	X	X	X			
871FT-3G			X	X	X	X	X	X	X	X	X	X	X	X	X	
871FT-4G	X	X	X	X	X	X	X	X	X	X	X	X	X			
871FT-3H		X	X	X	X	X	X	X	X	X	X	X	X			
871FT-4H	X	X	X	X	X	X	X	X	X	X	X	X	X	X		
871FT-3J	X	X	X	X	X	X	X	X	X	X	X	X	X			
871FT-4J	X	X	X	X	X	X	X	X	X	X						

NOTE

For Percent (%) Concentration Ranges for the 871FT English Flow-Through Sensors listed above, contact Foxboro.

PHYSICAL SPECIFICATIONS

Analyzer Enclosure

FOR PANEL MOUNTING

The housing is made of Noryl plastic and meets NEMA 1 requirements for general purpose, indoor applications. However, when installed in a panel, the front surface is protected by a gasketed, epoxy-painted, die cast, low copper aluminum bezel. This provides the front surface with the environmental and corrosion resistant protection of NEMA Type 4X, CSA encl. 4X, and IEC IP65.

FOR FIELD MOUNTING

The enclosure (housing, front bezel, and cover) is made from a die cast, low copper, aluminum alloy protected with an epoxy paint finish. The entire enclosure assembly provides the environmental and corrosion resistant protection of NEMA Type 4X, CSA encl. 4X, and IEC IP65.

Analyzer Mounting

The analyzer enclosure can be mounted to a panel, or field mounted to a surface or nominal DN 50 or 2-in pipe. When field mounted, a painted, low carbon steel bracket and a kit of mounting hardware is provided. See “Dimensions-Nominal” section.

Sensor Cable Length

33 m (100 ft) maximum

Electrical Connections

PANEL MOUNTED ENCLOSURE

Terminals for the field wiring are provided at the rear, stepped surfaces of the housing. The terminals are directly accessible without removing any cover(s). See “Dimensions-Nominal” section.

FIELD MOUNTED ENCLOSURE

Terminals are provided within the lower enclosure compartment. Field wires enter through holes in the bottom of the enclosure sized to provide for wiring conduit or cable glands. An easily removable bottom front cover, with captive screws, protects the field wiring compartment. See “Dimensions-Nominal” section.

Approximate Mass

PANEL MOUNTED ENCLOSURE

1.8 kg (4 lb)

FIELD MOUNTED ENCLOSURE

3.3 kg (7.3 lb)

Wiring Terminal Configuration, Designation, and Description

Figure 5 shows the terminal configuration and designation for both the panel and field mounted enclosures. Table 6 describes the use for each terminal.

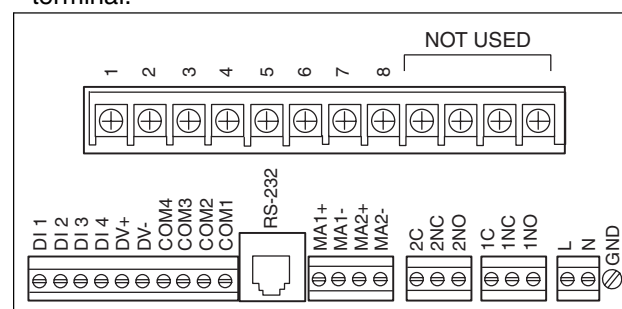

Figure 5. Wiring Terminal Configuration and Designation

Table 5. Wiring Terminal Designation and Description (See Figure 5)

Sensor Connections	
Terminal Designation	Terminal Description
1	Primary Sensor Drive
2	Primary Sensor Drive
3	Sensor Screen (Shield)
4	Sensor Return
5	Sensor Return
6	RTD Return
7	RTD Drive
8	RTD, Cable Length Compensation(a)
(a) Most Foxboro sensors contain 2-wire temperature compensation elements, in which case, terminal 8 is not used.	
Digital, Analog, Alarm, and Power Connections	
DI 1, 2, 3, 4	Digital Inputs
DV+, DV-	Power Source for Digital Inputs
COM 1, 2, 3, 4	Digital I/O Communications
MA1+, MA1-	Analog Output 1
MA2+, MA2-	Analog Output 2
1C, 1NC, 1NO	Alarm 1
2C, 2NC, 2NO	Alarm 2
L	Power, Line
N	Power, Neutral
GND	Power, Ground

ELECTRICAL SAFETY SPECIFICATIONS

Testing Laboratory, Type of Protection, and Area Classification	Application Conditions (a)	Electrical Safety Design Code
ATEX Ex protection 'n' for Zone 2; II 3 G EEx nC[L], IIC (c).	Temperature Class T4 where $20^{\circ}\text{C} \leq T_a$ to a maximum ambient temperature of 60°C (140°F). See certificate KEMA 02ATEX1329X.	N
CSA ordinary locations.	For panel mounted units, see note (b).	C
CSA for Class I, Division 2, Groups A, B, C, and D; Class II, Division 2, Groups F and G; and Class III, Division 2 hazardous locations.	Temperature Class T4. For panel mounted units, see note (b).	
FM ordinary locations.	For panel mounted units, see note (b).	F
FM nonincendive for Class I, Division 2, Groups A, B, C, and D; Class II, Division 2, Groups F and G; and Class III, Division 2 hazardous locations.	Temperature Class T4. For panel mounted units, see note (b).	
IECEX protection 'n' for Zone 2; Ex nA nL nC [nL] IIC.	Temperature Class T4 at maximum ambient temperature of 60°C (140°F).	D
UL ordinary locations.	---	U

(a) Specifications for the analyzers may differ from standard specifications. Refer to MI 611-206 for CSA and FM specifications, entity parameters, and special conditions of use. And refer to MI 611-208 for ATEX specifications, entity parameters, and special conditions of use.

(b) Panel-mounted unit must be installed as follows:
 For Ordinary and Class I, Division 2 locations: install in a protective enclosure to prevent access to live parts.
 For Class II and Class III Division 2 locations: install in a dusttight enclosure.

NOTE

The enclosures above must meet the ingress protection level required by the application, up to NEMA 4X or IP65.

(c) The L means that the unit contains energy limited circuits to the sensor.

OPTIONAL FEATURES AND ACCESSORIES

Option -A: Storm Door

This plexiglas door is attached to the front surface of the enclosure and hinges upward. It is used to prevent accidental or inadvertent actuation of front panel controls, and also useful in dusty or hose down environments, particularly in field mounting applications. The door is clear plastic to allow viewing of the display when closed, and also hinged to allow ready access to front panel controls. Specify Optional Selection “-A”.

Option -F: Configuration Utility

The configurator utility is a software package for use with Windows-based computer terminal. Use of this Windows-based software package allows remote configuration and calibration with the user's PC. Specify Optional Selection “-F”.

Option -C: Digital HART Communications Protocol

HART protocol replaces the secondary 4 to 20 mA measurement output signal. It operates using the frequency shift keying (FSK) principle. Measurements and diagnostics are available from the HART Communicator connected to the two-wire loop (carrying the 4 to 20 mA output) by using a bidirectional digital signal superimposed on the 4 to 20 mA current signal. Simultaneous analog and digital communications are thus provided without interrupting (or disturbing) any analog signal transmission that might be occurring. Both a Communicator and a PC-Based Configurator may be connected to each HART loop (see Figure 6). A minimum resistance of 250 ohms must be available in the communication circuit. Two measurement updates per second are communicated. Also, with HART communication, up to fifteen analyzers in a multidrop configuration can be connected on a single twisted pair of wires, or over leased telephone lines (see Figure 7). Specify Optional Selection “-C” for HART Protocol.

Options -N and -P: Rugged Construction

Rugged construction is offered with Options -N and -P. These options are only available with the 120 V ac Analyzer, and require the selection of the reinforced mounting bracket (Enclosure Mounting Selection 4). The rugged construction design allows hard mounting of the analyzers for Navy shipboard installations without performance degradation. They have been vibration tested per MIL Standard 167-1, and mechanical shock tested per MIL Standard 901, Grade A, Class I, Type C.

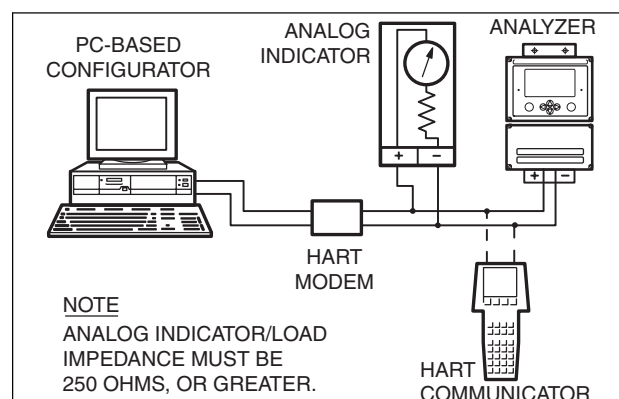

Figure 6. Point-to-Point Communications
4 to 20 mA Output with HART

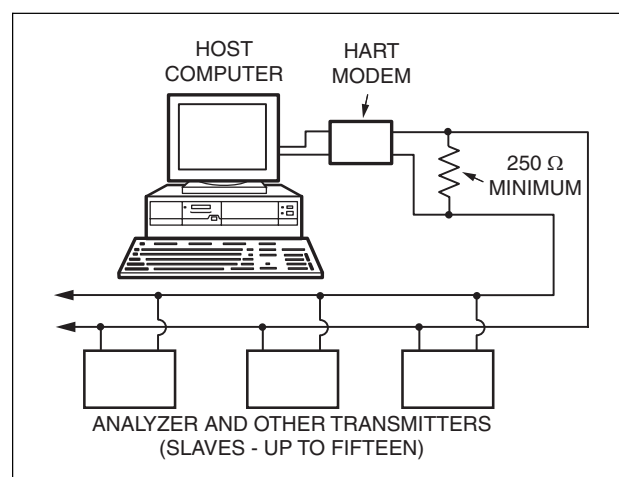

Figure 7. Typical Multidrop Configuration
4 to 20 mA Output with HART

MODEL CODE

Description	Model
Electrodeless Conductivity Intelligent Electrochemical Analyzer	875EC
Supply Voltage and Frequency	
120 V ac, 50 or 60 Hz (c)	-A
220 V ac, 50 or 60 Hz	-B
240 V ac, 50 or 60 Hz	-C
24 V ac, 50 or 60 Hz	-E
100 V ac, 50 or 60 Hz	-J
24 V dc (a)	-D
Enclosure Mounting	
Panel Mounting - Standard Construction (b)	1
Field Mounting to a DN50 or 2-in Pipe - Standard Construction	2
Field Mounting to a Surface, with standard mounting bracket - Standard Construction	3
Field Mounting to a Surface, with reinforced mounting bracket - Rugged Construction	4
Electrical Safety (also see “Electrical Safety Specifications” section)	
ATEX Protection “n” for Zone 2; II, 3, G; EEx [nL] nC IIC	N
CSA, Ordinary and Division 2 Locations, NI n (b)	C
FM, Ordinary and Division 2 Locations, NI n (b)	F
IECEX protection n for Zone 2; Ex nA nL nC [nL] IIC.	D
UL (Underwriter’s Laboratory) Ordinary Locations	U
Optional Selections	
Storm Door	-A
Digital HART Communication and 4 to 20 mA Output	-C
Configurator Utility (Windows-based Software)	-F
Rugged Construction, shock and vibration, with 4 to 20 mA Analyzer Outputs	-N
Rugged Construction, shock and vibration, with 0 to 10 V Analyzer Outputs	-P
Example: 875EC-A3F-A; 875EC-B2C-AC	

(a) The 24 V dc power selection provides a volts dc four-wire analyzer (it is not a loop powered 4 to 20 mA device).

(b) Panel mounted unit must be installed as follows:

- For Ordinary, and Class I, Division 2 locations: install in a protective enclosure to prevent accessibility to live parts.
- For Class II, and Class III, Division 2 locations: install in a dusttight enclosure.

NOTE

The enclosures above must meet the ingress protection level required by the application, up to NEMA 4X or IP65.

(c) The rugged construction options -N and -P are available only with:

- Supply voltage Code -A (120 V ac, 50 or 60 Hz)
- Enclosure Mounting Code 4 (field-mounted enclosure with reinforced mounting bracket).

DIMENSIONS-NOMINAL

**mm
in**

PANEL MOUNTED ENCLOSURE

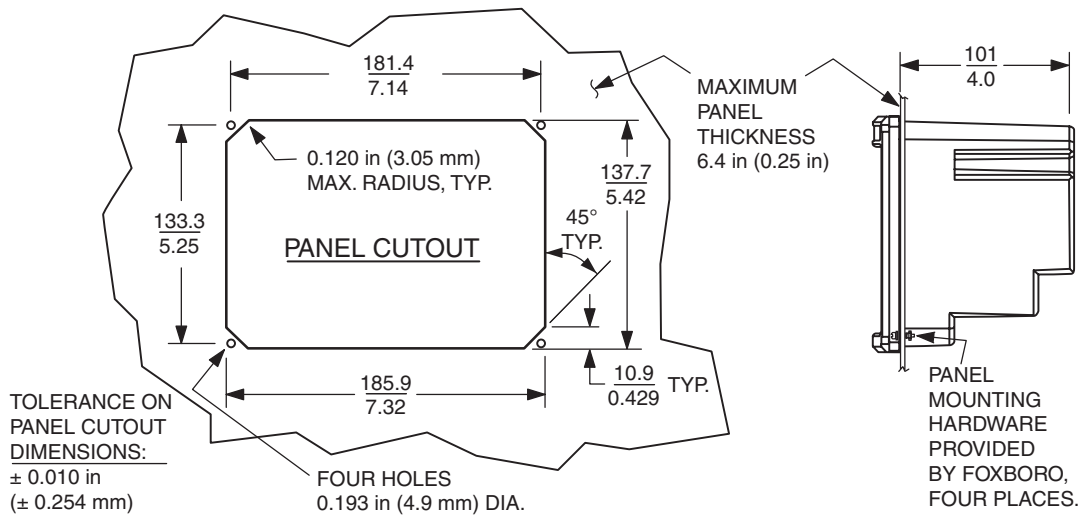
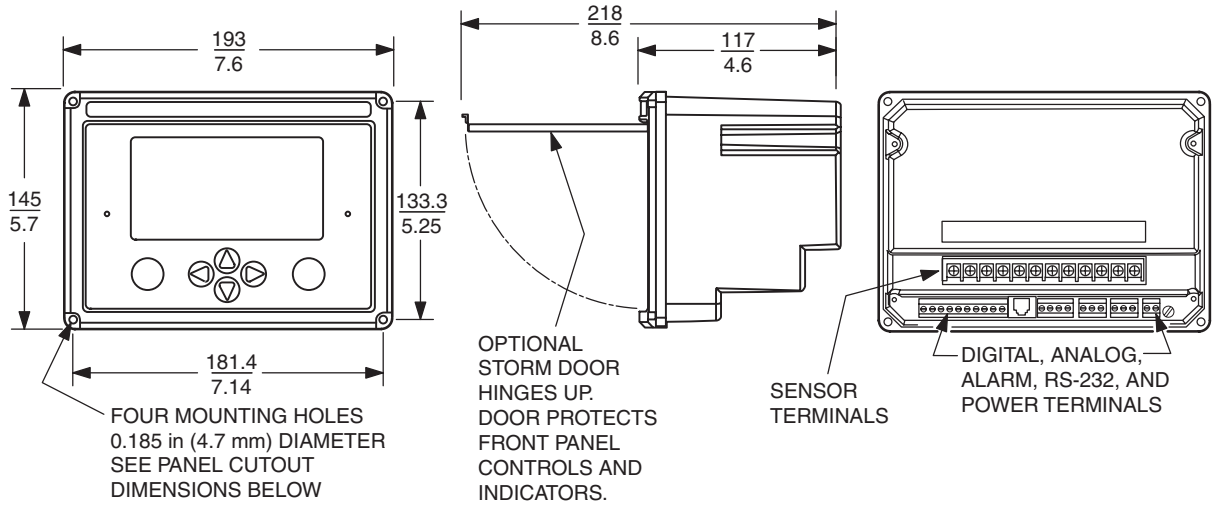

DIMENSIONS-NOMINAL (Cont.)

**mm
in**

**FIELD MOUNTED ENCLOSURE
(SEE NEXT PAGE FOR ENCLOSURE MOUNTED TO A SURFACE AND PIPE)**

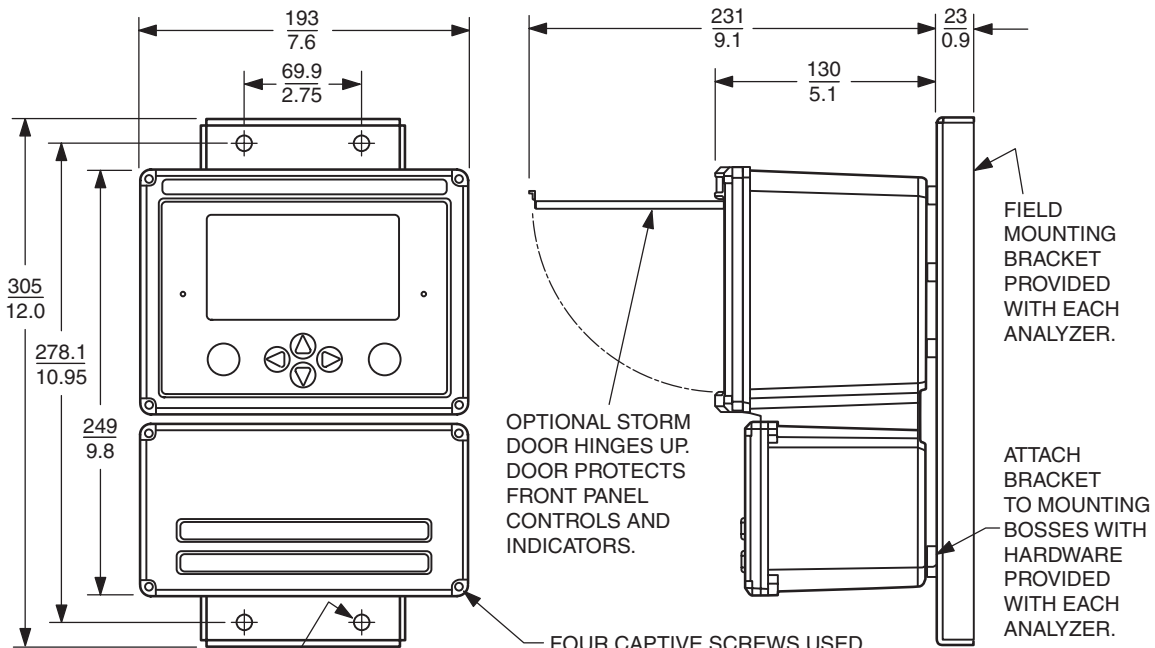

FOUR MOUNTING HOLES 0.348 in (8.84 mm) DIA. TO BE USED FOR MOUNTING ANALYZER TO A SURFACE, OR A DN 50 OR 2 in PIPE. SEE NEXT PAGE FOR FIELD MOUNTING CONFIGURATION.

FOUR CAPTIVE SCREWS USED TO SECURE/REMOVE BOTTOM COVER. REMOVE COVER TO ALLOW ACCESS TO FIELD TERMINALS. SEE FIGURE BELOW.

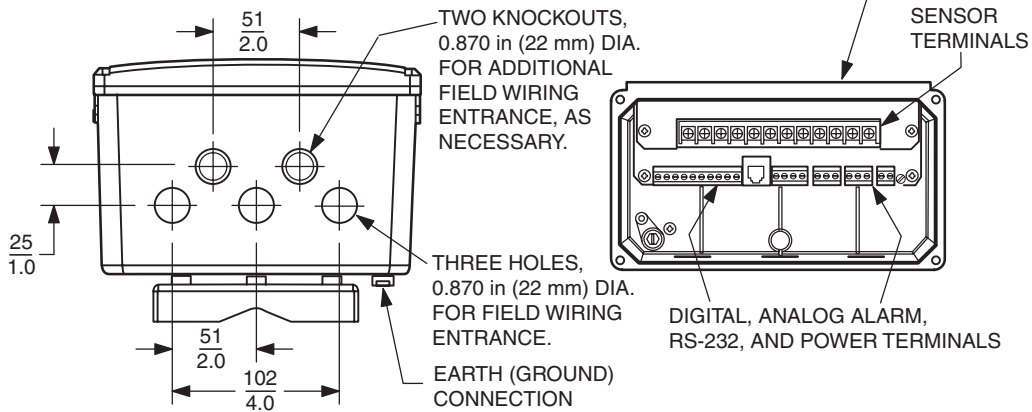

DIMENSIONS-NOMINAL (Cont.)

$\frac{\text{mm}}{\text{in}}$

SURFACE MOUNTED ENCLOSURE

USE APPROPRIATE
HARDWARE TO FASTEN
BRACKET TO MOUNTING
SURFACE.

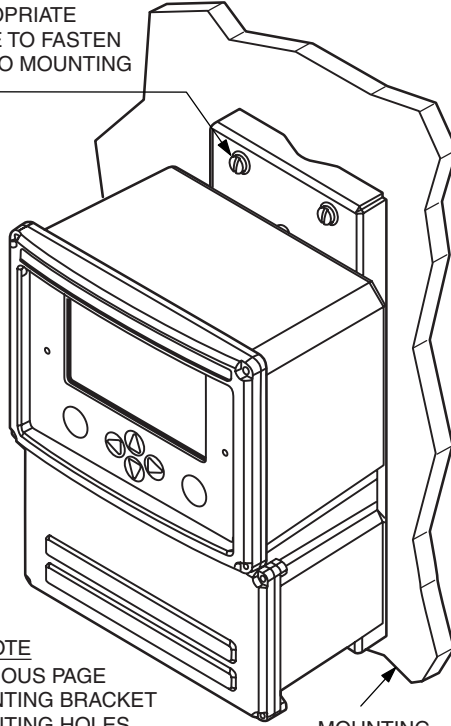

NOTE
SEE PREVIOUS PAGE
FOR MOUNTING BRACKET
AND MOUNTING HOLES
DIMENSIONAL DATA.

PIPE MOUNTED ENCLOSURE

PIPE MOUNTING KIT
(U-BOLTS, WASHERS,
AND NUTS) PROVIDED
BY FOXBORO.

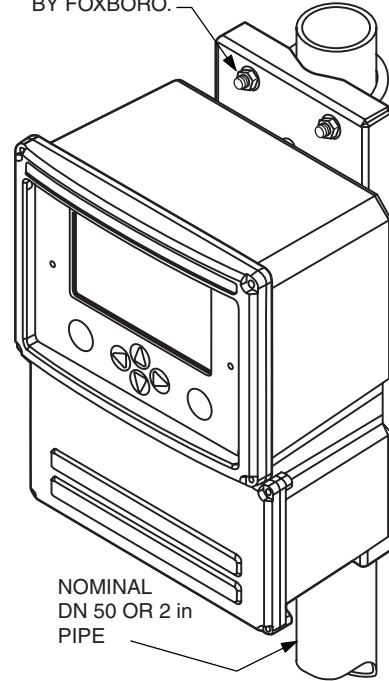

NOMINAL
DN 50 OR 2 in
PIPE

ORDERING INSTRUCTIONS

1. Model Number
2. Measuring Sensor Type; 871EC-SP, -PP, -RE, -LB, -HP, -BW, -UT, -NL, -TF, or -EV; or full Model Code of 871FT Flow-Through Sensor. (please specify sensor if other than that listed in Tables 2 and 4)
3. Measurement Range and Units
4. Temperature Compensation Type
5. Analog Output Range, Channel 1 and Channel 2
6. Temperature compensation Input
 - 871EC-SP, -PP, -RE, -LB, -NL, -TF, -EV; use 100 K Ω Thermistor
 - 871EC-HP, -BW, -UT; use 100 Ω RTD, 2-wire
 - 871FT, RTD Code "R"; use 1000 Ω RTD, 3-wire
 - 871FT, RTD Code "T"; use 100 Ω RTD, 2-wire
7. User Tag and Application

REFERENCE DOCUMENTS

Document Number	Document Description
PSS 6-3C4 A	871EC Series Electrodeless Conductivity Sensors and Accessories
PSS 6-3Q1 A	871FT Series Non-Invasive Sanitary and Industrial Flow-Through Conductivity Sensors
MI 611-206	Intrinsic Safety Connector Diagrams - FM, CSA, and IECEx
MI 611-208	Electrochemical Products Product Safety Information - ATEX
MI 611-220	Electrodeless Conductivity - System Calibration Examples
MI 611-224	875EC Intelligent Electrochemical Analyzer for Electrodeless Conductivity Measurements
Bulletin K99-5B	EP307B - Electrodeless Conductivity Sensors
Bulletin K99-6	EP307G - Electrodeless Conductivity Sensors
Bulletin K99-7B	EP402 - Electrodeless Conductivity Assemblies
Bulletin K99-8	EP485A - Calibration Plugs for Use with 871FT Sensors
Bulletin K99-9	EP485N - Calibration Plugs for Use with 871FT -8/-9 Sensors
Bulletin K99-10	EP485Q - Calibration Plugs for Use with 871EC and EP307 Sensors
Bulletin K107	Sensor Selector Wheel

OTHER M&I PRODUCTS

Invensys Foxboro provides a broad range of measurement and instrument products, including solutions for pressure, flow, analytical, positioners, temperature, controlling and recording. For a listing of these offerings, visit the Invensys Foxboro web site at:

www.foxboro.com/instrumentation

33 Commercial Street
 Foxboro, MA 02035-2099
 United States of America

www.foxboro.com
 Inside U.S.: 1-866-746-6477
 Outside U.S.: 1-508-549-2424
 or contact your local Foxboro representative.
 Facsimile: 1-508-549-4999

Invensys and Foxboro are trademarks of Invensys plc, its subsidiaries, and affiliates. All other brand names may be trademarks of their respective owners.

Copyright 2000-2006 Invensys Systems, Inc.
 All rights reserved

MB 010, 012

Printed in U.S.A.

1206