

**Features**

- 16-channel
- 24 V DC supply (Power Rail)
- HART field device input (revision 5 to 7)
- Up to 15 KFD0-HMS-16 slave units can be connected
- Up to SIL3 acc. to IEC 61508

**Function**

This HART Multiplexer Master operates up to 256 analog field instruments. The built-in slave unit in the HART master operates the first 16 field instruments. If more than 16 field instruments are required, up to 15 additional HART Multiplexer Slaves KFD0-HMS-16 can be connected.

The slave units are connected to the master with a 14-pin flat cable. The connector for the ribbon cable is found on the same housing side as the connectors for the interface and the power supply.

The analog signals are separately linked to a termination board via a 26-pin flat cable for each unit. Sixteen leads are reserved for the HART signal of the analog measurement circuits. The remaining 10 leads are sent to ground.

This unit is designed with removable terminals and can be connected to the Power Rail.

**Assembly**

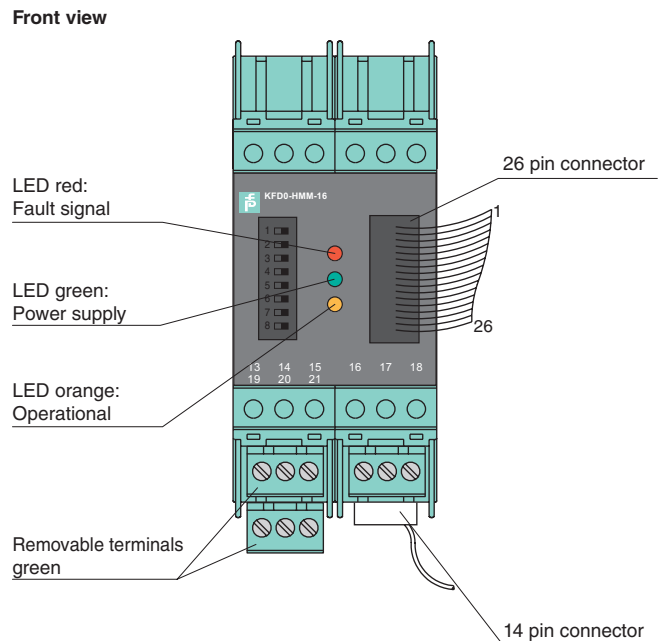

**SIL3**



**Connection**

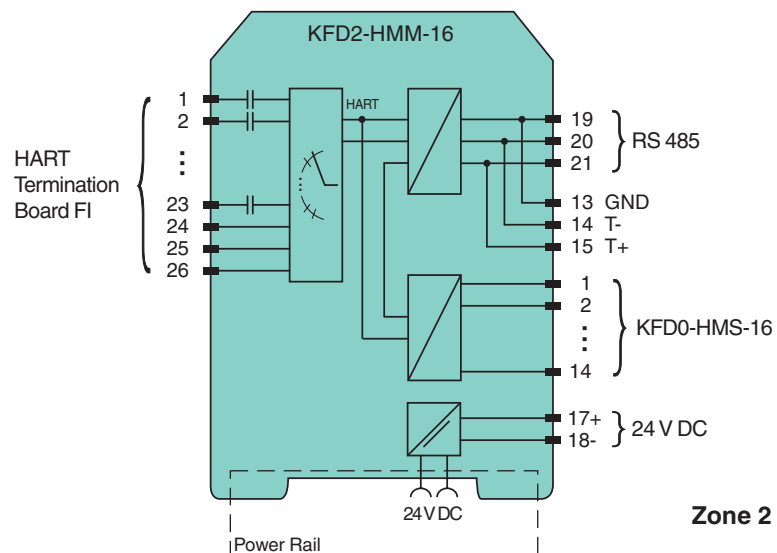

Release date 2015-02-18 14:27 Date of issue 2015-06-01 231289\_eng.xml

Refer to "General Notes Relating to Pepperl+Fuchs Product Information".

<b>Supply</b>	
Connection	terminals 17+, 18-
Rated voltage	$U_n$ 20 ... 32 V DC typical at 100 mA
Power consumption	≤ 3 W
<b>HART signal channels (non-intrinsically safe)</b>	
Conformity	HART field device input (revision 5 to 7)
Connection	26-pin flat cable for analog connections 14-pin flat cable for master-slave connection between KFD2-HMM-16 and KFD0-HMS-16
Leakage current	< 3 μA at -20 ... 85 °C (-4 ... 185 °F)
Terminating resistor	external 230 ... 500 Ω standard (up to 1000 Ω possible)
Output voltage	≥ 400 mV <sub>SS</sub> (with the terminator resistance specified above)
Output resistance	100 Ω or smaller, capacitive coupling
Input impedance	according to HART specification
Input voltage range	0.08 ... 4 V <sub>SS</sub> ; typ. ± 5.2 V as local reference
<b>Interface</b>	
Transfer rate	9600, 19200, or 38400 Bit/s (selectable with DIL switch (2 and 3) by the user)
Type	RS 485 2-wire multidrop
Address selection	One of 31 possible addresses selectable per DIL switch (4 ... 8)
<b>Directive conformity</b>	
Electromagnetic compatibility	
Directive 2004/108/EC	EN 61326-1:2006
<b>Conformity</b>	
Degree of protection	IEC 60529
<b>Ambient conditions</b>	
Ambient temperature	-20 ... 60 °C (-4 ... 140 °F)
<b>Mechanical specifications</b>	
Degree of protection	IP20
Mass	approx. 250 g
Dimensions	40 x 107 x 115 mm (1.6 x 4.2 x 4.5 in) , housing type C1
Mounting	on 35 mm DIN mounting rail acc. to EN 60715:2001
<b>Data for application in connection with Ex-areas</b>	
Statement of conformity	Pepperl+Fuchs (observe statement of conformity)
Group, category, type of protection, temperature class	⊕ II 3G Ex nA II T4 X
<b>General information</b>	
Supplementary information	Statement of Conformity, Declaration of Conformity, Attestation of Conformity and instructions have to be observed where applicable. For information see <a href="http://www.pepperl-fuchs.com">www.pepperl-fuchs.com</a> .

Release date 2015-02-18 14:27 Date of issue 2015-06-01 231289\_eng.xml

Refer to "General Notes Relating to Pepperl+Fuchs Product Information".

Pepperl+Fuchs Group  
www.pepperl-fuchs.com

USA: +1 330 486 0002  
pa-info@us.pepperl-fuchs.com

Germany: +49 621 776 2222  
pa-info@de.pepperl-fuchs.com

Singapore: +65 6779 9091  
pa-info@sg.pepperl-fuchs.com

**Additional information**

The KFD2-HMM-16 is a HART Multiplexer. The built-in slave unit can operate 16 analog transmitters. Up to 15 KFD0-HMS-16 slave units can be connected to each KFD2-HMM-16 HART Multiplexer. The slave units are linked to the KFD2-HMM-16 HART Multiplexer via a 14-pin bus cable.

The data of the individual transmitters is sent to a PC through an RS 485 interface. Via PC with a software such as **PACTware™** or AMS, a configuration of the HART compatible transmitter, as well as the registration of the processes with regard to a maintenance system can be carried out.

**DIP switch settings**

8 DIP switches are located on the top of the device.

DIP switch 1 is used by the manufacturer for testing the device and **must therefore always be set to "OFF"**.

DIP switch	1	Meaning
Setting	OFF	normal status

DIP switches 2 and 3 determine the baud rate of the RS 485 interface.

DIP switch	2	3	Meaning
Setting	OFF	OFF	9600 Baud
	OFF	ON	19200 Baud
	ON	OFF	38400 Baud
	ON	ON	not permitted

DIP switches 4 to 8 determine the RS 485 address. A value is assigned to each of the individual DIP switches for this purpose. The resulting address is given by the addition of the set values.

DIP switch	4	5	6	7	8	Meaning
Setting	ON					value 16
		ON				value 8
			ON			value 4
				ON		value 2
					ON	value 1
Example:	OFF	ON	ON	OFF	ON	address = 8 + 4 + 1 = 13

**Accessories**

**Connection cable**

- K-HM14 Connecting cable Multiplexer Master to Multiplexer Slave, standard length (0.45 m) or custom length (up to 8 m)
- K-HM26 Connecting cable Multiplexer Master or Multiplexer Slave to Termination Board, standard length (1 m) or custom length (up to 8 m)

**Termination Board**

- FI-PFH-NS0137-R Connection board for K-System HART Multiplexer, 16-channel, interface for series connections, integrated, switchable 220 Ω resistor

Release date 2015-02-18 14:27 Date of issue 2015-06-01 231289\_eng.xml

Refer to "General Notes Relating to Pepperl+Fuchs Product Information".

## Accessories

### Power feed module KFD2-EB2

The power feed module is used to supply the devices with 24 V DC via the Power Rail. The fuse-protected power feed module can supply up to 150 individual devices depending on the power consumption of the devices. Collective error messages received from the Power Rail activate a galvanically-isolated mechanical contact.

### Power Rail UPR-03

The Power Rail UPR-03 is a complete unit consisting of the electrical insert and an aluminium profile rail 35 mm x 15 mm. To make electrical contact, the devices are simply engaged.

### Profile Rail K-DUCT with Power Rail

The profile rail K-DUCT is an aluminum profile rail with Power Rail insert and two integral cable ducts for system and field cables. Due to this assembly no additional cable guides are necessary.



*Power Rail and Profile Rail must not be fed via the device terminals of the individual devices!*