

# I/A Series<sup>®</sup> Intelligent Magnetic Flow Transmitters

## Model IMT25

### with FoxCom<sup>™</sup> or HART<sup>®</sup> Communication Protocol

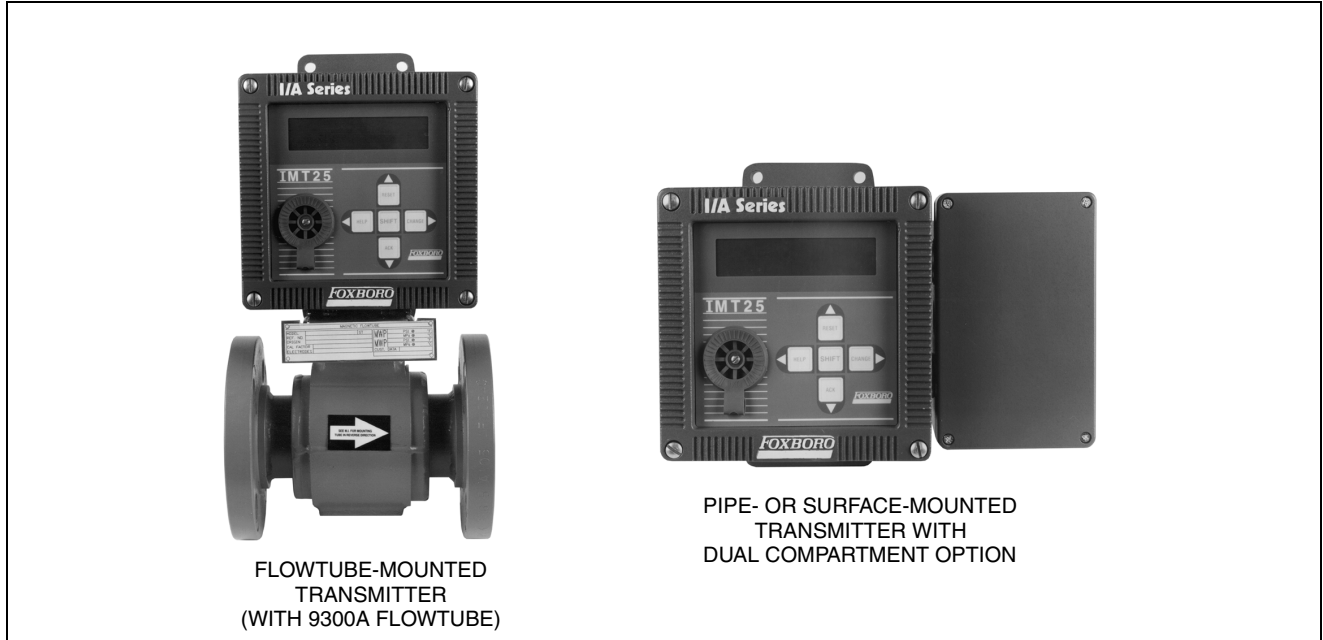

The IMT25 Magnetic Flow Transmitter, together with an 8000A Wafer Body, or 2800, 8300, 9100A, 9200A, or 9300A Flanged Body Flowtube, combines to form a Magnetic Flowmeter with pulsed dc excitation.

#### FEATURES

- Compatible with Foxboro family of flowtubes.
- Digital precision, stability, and resolution ensure top measurement performance.
- Remote communication via FoxCom or HART Communication Protocol. For FOUNDATION<sup>®</sup> Fieldbus Protocol, refer to PSS 1-6F5 B.
- Remote configuration using I/A Series System Workstation, Foxboro PC-Based Configurator, or HART Communicator.
- Local configuration using optional integral keypad, with backlit, 2-line, LCD display.
- Compact single or dual compartment.
- Enclosure meets NEMA<sup>®</sup> 4X and IEC IP66.
- Scaled or frequency pulse output.
- Unidirectional or bidirectional flow.
- Analog output programmable for unidirectional, bidirectional, or multiple input range.
- Relay outputs with programmable functionality for alarms.
- Contact inputs with programmable functionality for remote operation.
- Automatic and manual zero lock.
- Online diagnostic help.
- Software configuration and totals protected in nonvolatile memory in the event of power loss.
- Intrinsically safe electrodes circuit (European applications only).
- Conforms to applicable European Union Directives (product marked with "CE" logo).
- 85 to 264 V ac or 24 V dc input power options.
- Optional I/O access port allows direct external connection of remote configurator.
- Field test mode using Foxboro Model IMTSIM Magnetic Flow Simulator.
- Standard 2-year warranty.

## SUPERIOR REPUTATION FOR DEPENDABILITY AND QUALITY

Foxboro introduced magnetic flow measurement systems to the process industries in 1954, and has demonstrated the broadest and most time-proven application expertise with tens of thousands of successful installations.

### A SELECTION OF OUTPUT SIGNALS

The Model IMT25 Transmitter provides digital, analog, and pulse output signals, as described below.

The Digital Output Signal utilizes either FoxCom or HART communication protocol (see PSS 1-6F5 B for FOUNDATION Fieldbus Protocol). This signal allows remote communications and configuration. FoxCom communications can be performed using an I/A Series System Workstation or a Foxboro PC-based Configurator at any point in the loop. The FoxCom output signal has a 4800 baud transmission rate. Alternatively, the 1200 baud HART digital output allows remote communications with the HART Communicator.

The 4 to 20 Analog Output Signal can be configured to operate in one of four ways: unidirectional (single range), unidirectional (multiple range), bidirectional, and bidirectional split range. The transmitter can be programmed for up to three different flow ranges for unidirectional flow. For bidirectional flow, the user can input a separate flow range for the forward and reverse flow directions. Alternatively, the output can be programmed, as bidirectional split range, where 12 mA represents zero flow, 4 mA represents the reverse flow upper range value, and 20 mA represents the forward flow upper range value. The analog output can be internally or externally powered, and is independently isolated. A digital signal is superimposed on the analog signal for remote communications. The superimposed FSK signal has a 600 baud transmission rate using the FoxCom protocol. The analog output signal is not available simultaneously with the FoxCom high baud (4800) digital output signal. The 1200 baud HART signal permits simultaneous use of the analog output.

The Pulse Output can be configured for frequency mode or scaled mode. It is independently isolated from fluid ground and can be internally or externally powered. Frequency mode would be selected (for example) to drive an external rate meter. Maximum output frequency is selectable between 1000 and 10 000 Hz. Scaled mode would be selected (for example) to drive an external totalizer. Maximum output frequencies of 10 and 100 Hz are available. The pulse output is available simultaneously with either the analog or digital output signal.

## MULTIPLE PACKAGING CONFIGURATIONS

The IMT25 enclosure accommodates all of the electronics and terminations in a single compartment. An optional second enclosure, attached to the primary enclosure, is offered for users who require the wiring terminals to be isolated and sealed from the electronics compartment. The transmitter can be used as a remote-mounted transmitter, or can be mounted directly to an 8000A or 9300A Series Flowtube as an integral and complete magnetic flow system. See Figure 1.

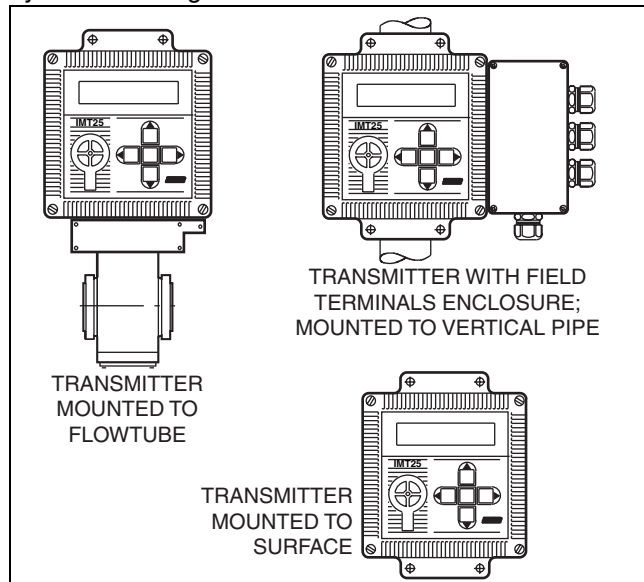

Figure 1. Multiple Packaging Configurations

## COMPATIBILITY WITH MANY FLOWTUBES

This Intelligent Transmitter can be used with 8300, 8000A, 9100A, 9200A, and 9300A Series Flowtubes. It can also be used with existing 2800 and 8000 Series Flowtubes. This provides an advanced microprocessor-based, dc-pulsed magnetic flow system (and corresponding features) regardless of the Foxboro flowtube used.

## CONTACT INPUTS AND CONTACT OUTPUTS

Transmitter can accept two contact closure inputs. The function(s) of these inputs are programmable, and allow the user to perform transmitter functions from a remote location. Some functions of these inputs include: selection of flow range, resetting totals, and acknowledging alarms. (Both contacts must be used for multiple range service.) The transmitter also provides two contact (relay) outputs with programmable functionality. These outputs can be used to indicate reverse flow, alarm conditions (i.e., high flow rate, low flow rate, or high flow totals), and/or diagnostic alarms.

### NOISE REDUCTION ALGORITHM

Provides superior noise reduction in noise generating processes without high damping. This results in a system with a fast speed of response and excellent zero stability.

### ON-LINE DIAGNOSTICS WITH HELP FUNCTION

While in the RUN mode, the IMT25 continuously performs many internal diagnostic functions. The display automatically indicates any diagnostic condition that is detected, and can actually be programmed to blink for a diagnostic error, thus easily drawing the attention of floor personnel. In addition, the IMT25 can be programmed to energize one or both of the alarm relays for a diagnostic error.

Diagnostic Error messages are displayed in clear text. Each error has an associated help message that can be displayed by pressing the HELP button whenever the diagnostic prompt appears. The diagnostic help message gives the user more detailed information on the potential problem, as well as potential trouble shooting techniques to eliminate the problem.

### LOW POWER CONSUMPTION

The transmitter can accept either 85 to 264 V ac or 24 V dc power. With either supply, the power consumption is less than 24 watts.

### CALIBRATION

All transmitters are factory-calibrated to their specified accuracy with calibration equipment traceable to U.S. National Institute of Science and Technology (NIST).

### AUTOMATIC OR MANUAL ZERO LOCK

Automatic or Manual Zero Lock can be used to lock all rate outputs at zero percent (zero flow) and freeze all totals. The display indicates when the zero lock is activated. In Manual mode, the zero lock can be activated/deactivated at any time by an external contact closure supplied by the user. In the Automatic mode, it can be used to issue an alarm and/or lock all outputs when an increase in electrode impedance is detected, such as can occur when a pipe is empty.

### CE COMPLIANCE

These transmitters display the "CE" designation indicating conformance to the appropriate European Community Standards, for immunity to sources of EMI and conformance to RF emission limits.

### SIMPLE, MENU-DRIVEN SOFTWARE WITH INTEGRAL HELP FUNCTION

The IMT25 is configured by exiting the Run mode and entering the Set-Up mode. The configuration is in matrix form, with each row of the matrix dedicated to a particular function. Each matrix row, namely System, Outputs, Alarms, Diagnostics, Identity, Passcodes, Transmitter, and Calibration, has programming or menu blocks that allow the user to enter data to configure that particular function.

The user scrolls through the matrix using the keys on the front panel keypad (as shown and described in Table 1). The user, starting in the first row, scrolls to visit all the menu blocks in that row and provides the needed information. He continues this process to the other rows until all required functions have been configured.

This versatile instrument provides many different functions. Simple applications that require, for example, only three menu blocks, can be configured in just a few minutes.

The transmitter is easy to configure because easy-to-read prompts and icons have been preprogrammed to assist the first time user. All menu blocks have help messages that clearly tell the user what information is required in that block, and how to enter it. The help message can be displayed by depressing the HELP key whenever the prompt for that block appears. These messages are like having the instruction book programmed into the memory of the unit.

Table 1. Function of Keys

	
Key	Function
UP ARROW	<ul style="list-style-type: none"> <li>Move up in product structure.</li> <li>Scroll up in menu, list of characters, or on-line Help message.</li> </ul>
SHIFT + RESET	<ul style="list-style-type: none"> <li>Reset totals and empty pipe count.</li> </ul>
DOWN ARROW	<ul style="list-style-type: none"> <li>Move down in product structure.</li> <li>Scroll down in menu, list of characters, or on-line Help message.</li> </ul>
SHIFT + ACK	<ul style="list-style-type: none"> <li>Acknowledge alarm or diagnostic messages.</li> </ul>
LEFT ARROW	<ul style="list-style-type: none"> <li>Move to left in product structure.</li> <li>Cancel parameter selection or data entry.</li> </ul>
SHIFT + HELP	<ul style="list-style-type: none"> <li>Access on-line Help.</li> </ul>
RIGHT ARROW	<ul style="list-style-type: none"> <li>Move to right in the product structure.</li> <li>Enter parameter selection or data entry.</li> </ul>
SHIFT + CHANGE	<ul style="list-style-type: none"> <li>Access Edit mode.</li> </ul>

**FRONT PANEL OPTIONS**

A display/keypad, a protective cover with a clear plastic window guard, and an I/O access port with cover are front panel options. See Figure 2.

The display consists of a 2-line, 16 characters per line, back-lighted LCD indicator. The characters are 10 mm (0.4 in) high and can indicate positive total, negative total, net total, net inventory total, and rate in conventional flow units. A “+” or “-” indicates flow direction. The keypad has five keys as previously described in Table 1. This option allows the transmitter to be used as a stand-alone unit and gives the user complete operation and configuration capabilities.

The cover with a clear plastic window protects the display/keypad during washdown operations and prevents inadvertent activation of the buttons by the washdown stream. However, the front panel is protected to NEMA 4X even without the cover.

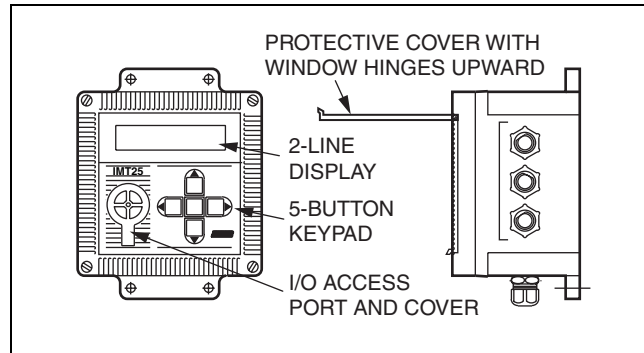

Figure 2. Front Panel Options

The circular I/O access port has a cover integrally connected to the panel to prevent loss or misplacement. Loosening a screw on the cover provides access to two banana plug sockets. These sockets allow direct connection to either FoxCom or HART Communication protocols. This option negates the need to remove the housing cover to access the above terminals.

**OPERATING CONDITIONS**

Transmitter Influence	Reference Operating Conditions	Normal Operating Condition Limits	Operative Limits
Ambient Temperature(a) without LCD Indicator	23 ±2°C (73 ±3°F)	-20 and +55°C (-4 and +131°F)	-30 and +70°C(b) (-22 and +158°F)(b)
Ambient Temperature(a) with LCD Indicator	23 ±2°C (73 ±3°F)	-20 and +55°C (-4 and +131°F)	-20 and +70°C(b) (-4 and +158°F)(b)
Process Temperature(a)	23 ±2°C (73 ±3°F)	See Note (a)	See Note (a)
Relative Humidity	50 ±10%	5 and 100%(c)	5 and 100%(c,d)
Supply Voltage • ac Voltage • dc Voltage	• 120 V ac, 240 V ac • 24 V dc, 1.5 A min.	• 85 and 264 V ac • Rated Voltage ±20%	• 85 and 264 V ac • Rated Voltage ±20%
Supply Frequency	50 or 60 Hz	Rated Frequency ±3 Hz	47 and 63 Hz
4 to 20 mA Output • Supply Voltage • Load	• 24 V dc • 250 Ω	• 12 and 50 V dc • 0 and 1950 Ω	• 12 and 50 V dc • 0 and 1950 Ω
Pulse Output • Supply Voltage • Load	• 24 V dc • 480 Ω	• 5 and 42 V dc • 1 and 80 mA dc	• 5 and 42 V dc • 1 and 80 mA dc
Vibration	Negligible	0 and 5 m/s <sup>2</sup> (0 and 0.5 “g”) from 5 to 500 Hz	5 m/s <sup>2</sup> (0.5 “g”)(e) up to 500 Hz

- (a) Process temperature is not applicable to pipe- or surface-mounted transmitters. However, with flowtube mounting, the ambient temperature operative limit of 70°C (158°F) must not be exceeded. Also, the process temperature is limited to 121°C (250°F).
- (b) During transportation and storage, the ambient temperature limits are -40 and +85°C (-40 and 185°F) without an LCD Indicator; and -30 and +80°C (-22 and +176°F) with an LCD Indicator.
- (c) Relative humidity limits listed apply only with transmitter covers properly installed.
- (d) During transmitter transportation or storage, the relative humidity limit is 0 and 100% with transmitter covers properly installed.
- (e) During transportation, the packaged transmitter can withstand normal handling and shipping conditions without damage.

**SYSTEM PERFORMANCE SPECIFICATIONS – TRANSMITTER AND FLOWTUBE**  
(At Reference Operating Conditions unless Otherwise Specified)

**Accuracy Notes**

- Accuracy specified as percent of flow rate reading, unless otherwise indicated.
- Accuracy specified using water as the fluid at reference operating conditions.
- Accuracy specified with 8000A, 8300, 9100A, 9200A, 9300A, and 2800 Series Flowtubes
- Accuracy rating assumes no flange piping mismatch, and also assumes a straight pipe upstream (5 pipe diameters minimum) and a straight pipe downstream (3 pipe diameters minimum) measured from center of flowtube.
- Accuracy rating includes effects of hysteresis, linearity, zero error, and repeatability.

**Accuracy – Pulse and Digital Output; with 8000A, 8300, and 2800 Series Flowtubes**

8000A	8300	2800(a)	System Accuracy	Flow Velocity
1/2 to 6 in (15 to 150 mm)	1/2 to 18 in (15 to 450 mm)	None	±0.25% of Reading	≥2.0 fps (≥0.61 m/s)
			±0.005 ft/s (±0015 m/s)	<2.0 fps (<0.61 m/s)
1/16 to 1/4 in (1.16 to 6 mm)	20 to 36 in (500 to 900 mm)	None	±0.50% of Reading	≥2.0 fps (≥0.61 m/s)
			±0.010 ft/s (±0305 m/s)	<2.0 fps (<0.61 m/s)
None	None	All Sizes	±1.00% of Reading	≥3.3 fps (≥1 m/s)
			±0.033 ft/s (±010 m/s)	<3.3 fps (<1 m/s)

(a)Values in table above are for 2800 Series Flowtubes that have been calibrated for use with IMT25 Transmitters. An average factor can be used, at a reduced accuracy, for 2800 Series Flowtubes that do not have an IMT25 Transmitter calibration factor.

**Accuracy – Pulse and Digital Output; with 9100A, 9200A, and 9300A Flowtubes**

9100A	9200A	9300A	System Accuracy	Flow Velocity
None	None	1/2 to 6 in (25 to 150 mm)	±0.25% of Reading	≥2.0 fps (≥0.61 m/s)
			±0.005 ft/s (±0.0015 m/s)	<2.0 fps (<0.61 m/s)
1 to 78 in (25 to 2000 mm)	8 to 40 in (200 to 1200 mm)	8 to 16 in (200 to 400 mm)	±0.50% of Reading	≥2.0 fps (≥0.61 m/s)
			±0.010 ft/s (±0.00305 m/s)	<2.0 fps (<0.61 m/s)

**Accuracy – 4 to 20 mA Output**

Same as for pulse and digital outputs except add ±0.03% of span (which equates to ±0.0048 mA) to pulse and digital accuracy values above.

**Response Time**

Digital and Pulse		4 to 20 mA
50 Hz	60 Hz	Add 0.150 sec
0.2 sec	0.167 sec	

**Ambient Temperature Effect**

(For any variation from Reference Operating Temperature within the Operating Limits)

DIGITAL OUTPUT

< 0.5% of span

4 to 20 mA OUTPUT

< 1% of span

PULSE OUTPUT

< 0.5% of span

**RFI Effect**

The output error is less than 5% of calibrated span for radio frequencies in the range of 27 to 1000 MHz and field intensity of 10 V/m when the transmitter is properly installed and housing covers are in place.

**Supply Voltage Effect**

DIGITAL AND PULSE OUTPUT

A change in supply voltage of +10 or -15% from reference can cause the output to change <0.1% or <0.15% of reading, or <0.001% or 0.0015% of flowmeter capacity, whichever is greater.

4 TO 20 mA OUTPUT

Digital/Pulse output effect plus an additional error of 0.005%/volt

**RFI Effect**

The output error is less than 5% of calibrated span for radio frequencies in the range of 27 to 1000 MHz and field intensity of 10 V/m when the transmitter is properly installed and housing covers are in place.

---

**PERFORMANCE SPECIFICATIONS (Cont.)**
**Switching and Indirect Lightning Transients**

Can withstand 1000 V common mode and 500 V normal mode, 1.2 x 20  $\mu$ s impulse per ANSI/IEEE Standard C62.41-1980 and IEC Standard 801-5.

**High Frequency Transients**

Can withstand a high frequency transient of 2000 V common mode, 5 x 50 ns impulse (IEC Std. 801-4).

**Electrostatic Discharge**

Can withstand application of 6000 V contact discharge, or 8000 V air discharge of an electrostatic field per IEC Standard 801-2.

**European Union Directives**

- Complies with Electromagnetic Compatibility Requirements of European EMC Directive 89/336/EEC by conforming to the following CENELEC and IEC Standards: EN 50081-2, EN 50082-2, and IEC 801-2 through 801-6.
- Complies with NAMUR Part 1 Interference Immunity Requirement (EMC).
- Conforms to Applicable European Union Directives ("CE" Logo marked on product)

**FUNCTIONAL SPECIFICATIONS****Flow Velocity Limits**

LOW FLOW CUTOFF (For Rate Indicator, Pulse Outputs, and Digital Outputs)

0.01 m/s (0.033 ft/s)

MAXIMUM VELOCITY

10 m/s (33 ft/s)

MINIMUM URV (Upper Range Value)

0.5 m/s (1.65 ft/s)

**Measurements**

BIDIRECTIONAL FLOW

"+" or "-" rate in engineering units

"+" or "-" rate in % of URV

TOTALIZATION

"+" or "-" bidirectional total, 8 digits

Net total, 8 digits

Net inventory total, 10 digits

**Power Consumption**

Less than 24 W at reference voltage and frequency

**Output Damping**

Field-programmable from 0.1 to 49.9 seconds. This feature is used for reducing the frequency response of the transmitter as required by the process.

**Automatic Zero Lock (Empty Tube Zero)**

This function automatically drives the analog, pulse, and digital output signals to zero flow rate when the flowtube's electrodes become uncovered by the conductive liquid.

**Ranging**

The transmitter is easily adjusted for the desired flow rate units and to the required upper range value. This range data may also be keyed in through an external configurator, or optional LCD indicator and keypad.

**Preset/Calibration**

The transmitter may be used as an analog or pulse generating source to check and/or calibrate other instruments in the output loop, such as indicators, controllers, and recorders. This feature may be activated locally by pressing pushbuttons. The output signals can also be adjusted to any value, remotely, via an external configurator.

**Self-Test**

During power up and periodically during normal operations, the electronics will self-test the system to identify the presence of any faults, and isolate the fault to the transmitter or flowtube.

**Test Mode**

Transmitter calibration accuracy can be verified using a Foxboro Model IMTSIM Magnetic Flow Simulator. The IMT25 has a Test mode to facilitate the test and provide a way to log the test date into the transmitter. (See PSS 1-6F7 A for more information on the Model IMTSIM Magnetic Flow Simulator.)

**Low Flow Cut-Off**

A low flow cut-off algorithm stops the pulse output, rate indicator, and digital measurement value when the measurement signal falls below a velocity of 0.033 ft/s. Note that there is no low flow cut-off with 4 to 20 mA current output.

### Output Signals

Three electrical output signals are available - Digital, 4 to 20 mA, and Pulse. The Digital Output utilizes either FoxCom or HART protocol. All three output signals are available simultaneously except that the 4 to 20 mA output is not available with 4800 baud FoxCom, or when HART is configured for Multidrop operation.

#### DIGITAL OUTPUT (4800 Baud)

Transmitter transfers digital information using FoxCom communication protocol.

#### 4 TO 20 mA OUTPUT WITH SUPERIMPOSED DIGITAL OUTPUT (600 Baud FoxCom or 1200 Baud HART)

The current output is independently isolated and can be internally or externally powered. The current output is also configurable to a 4 to 12 and 12 to 20 mA split range for bidirectional flow applications. Minimum current is 3.9 mA and maximum current is 22 mA.

#### PULSE OUTPUT

This is a 2-wire solid state type output, and is configurable as a scaled pulse or frequency output. Pulse output is available simultaneously with 4 to 20 mA or digital output.

#### Scaled Pulse Output Mode

Speed Selection	Pulse Width	Maximum Frequency
Slow	50.0 ms	10 Hz
Medium	5.0 ms	100 Hz

#### Frequency Output Mode (Unidirectional Only)

0 Hz to either 1, 2, 5, or 10 kHz, user programmable

### Contact Inputs

Quantity: 2

Type:

Requires current sinking device such as contact closure or transistor switch between terminal block connections provided. The contact inputs share the same circuit reference, but are isolated from the flowtube ground.

Voltage Rating (Open Circuit Voltage):

24 V dc, ±15%

Current (Closed Circuit Current):

12 mA, ±15%

### Relay Outputs

Quantity: 2

Type: Relay, 1 form A (isolated)

Voltage Rating:

60 V dc maximum

30 V ac rms maximum

Current Rating:

3 amps maximum resistive

### Supply Voltage – 4 to 20 mA Output

#### 4 TO 20 mA OUTPUT–INTERNALLY POWERED

Output may share the same circuit reference as the pulse output, if pulse output is also internally powered. This circuit reference may only be grounded in one location.

Voltage	Load Resistance Range(a)
24 V dc ±15%	0 to 500 Ω

(a) A 200 Ω load resistor is required to allow communications.

#### 4 TO 20 mA OUTPUT–EXTERNALLY POWERED

Analog output is independently isolated from fluid ground. Refer to Figure 3 for a graph of external supply voltage vs. output load resistance.

$$R_{MAX} = \frac{V_S - 10}{0.0205} \Omega$$

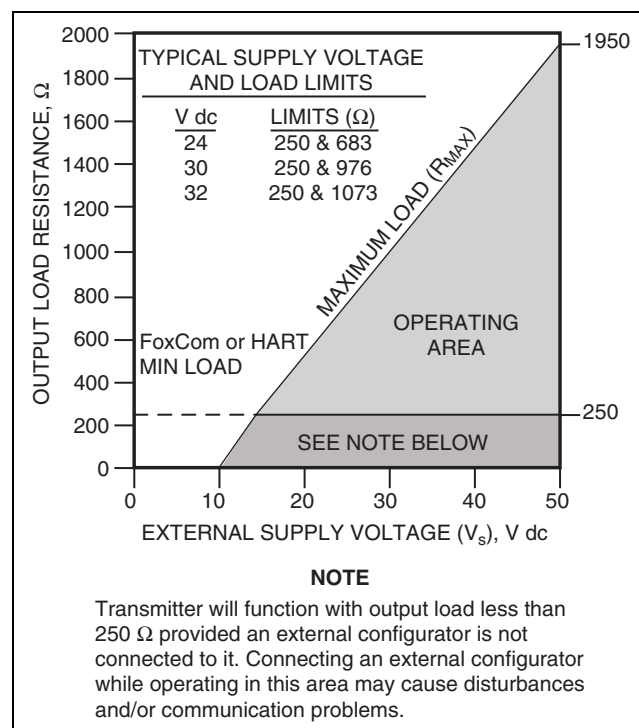

Figure 3. 4 to 20 mA Output, External Supply Voltage vs. Output Load Resistance

### Transmitter Voltage

120 or 240 V ac, 50 or 60 Hz; or 24 V dc

### Digital Output

Powered by transmitter, or by the I/A Series System

---

**FUNCTIONAL SPECIFICATIONS (Cont.)**
**Pulse Output – Internally Powered**

Pulse output may share the same circuit reference as the current output. This circuit reference can only be grounded in one location.

**VOLTAGE**

24 V dc  $\pm 15\%$

**CURRENT**

1 mA minimum to 80 mA maximum

**OFF-STATE LEAKAGE**

200  $\mu$ A maximum

**Pulse Output – Externally Powered**

Output is independently isolated from fluid ground.

**VOLTAGE**

5 to 42 V dc

**CURRENT**

1 mA minimum to 80 mA maximum

**OFF-STATE LEAKAGE**

200  $\mu$ A maximum

**Diagnostics and Alarms**

The transmitter provides internal diagnostics and configurable alarm functions (low flow, high flow, and high totals). The display automatically indicates any existing diagnostic or alarm condition. The relay outputs can be configured to activate on an alarm or diagnostic condition to provide remote indication of such events. Also, the analog output can be configured to go upscale, downscale, or remain active when an alarm condition exists. For diagnostic conditions, the analog output can be configured to go downscale or upscale. Diagnostics and alarms are also communicated via the Digital Output.

**Multidrop Communications (HART Only)**

Either point-to-point (one transmitter) or multidropping is permitted. Multidropping is the connection of several transmitters to a single communications line. Communication between the host computer and transmitters occurs digitally with analog output of transmitter deactivated. With HART communications protocol, up to fifteen transmitters can be connected on a single twisted pair of wires or over leased telephone lines. The maximum cable length conforms to the HART Physical Layer Specification and will vary according to the characteristics of the individual transmitters in a multidrop environment.

**Digital Communications**

The transmitter communicates bidirectionally over the field wiring to the PC-based Configurator or the HART Communicator (installed anywhere in a Division 2 area along the 4 to 20 mA loop). The FoxCom version also allows communication to a Foxboro PC-based Configurator, and/or the I/A Series System. Using the local display/keypad, or digital communications, the functions that can be performed are:

- Display/Reconfigure Measurement Information
  - Flow Rate in EGUs
  - Flow Rate in % of URV
  - Flow Direction
  - Forward, Reverse, Net, and Grand Total
  - Flow Rate Damping
  - Meter Factor (Calibration Factor)
- Display/Reconfigure Transmitter Status and Configuration
  - Transmitter Output Mode (FoxCom Only)
  - Outputs (Uni/Bidirectional, Dual, Multi, or Split Range)
  - Alarm Functions, Set Points, and Deadbands
  - Noise Reduction
  - Automatic Zero Lock
  - Output Response to Alarms/Diagnostics
  - Passcodes Protection
  - Contact Inputs Status and Function
  - Contact Output Status and Function
- Display/Reconfigure Transmitter Identity
  - Flowtube Model Number
  - Flowtube Serial Number
  - Tag Information
  - Poll Address (HART Only)
- Display/Operate Diagnostic and Calibration Functions
  - 4 to 20 mA and Pulse Output Preset
  - 4 to 20 mA Calibration
  - Online Diagnostics

**Communications Format**

Both FoxCom and HART protocols are based upon the FSK (Frequency Shift Keying) technique. The FSK tones are superimposed on the transmitter 4 to 20 mA output leads. Communication between the external configurator and the transmitter does not disturb the output signal. The following paragraphs describe the 4 to 20 mA output with superimposed digital output (FoxCom and HART), and the digital output signal with FoxCom only.



**Communications Format (Cont.)**

**4 to 20 mA OUTPUT WITH SUPERIMPOSED DIGITAL OUTPUT (FoxCom and HART)**

The transmitter sends its measurement to the loop as a continuous 4 to 20 mA dc signal. This version communicates with the external configurator at distances up to 1800 m (6000 ft). The Digital, 4 to 20 mA, and Pulse Outputs are each updated 10 times/second. The maximum scan frequency for the Digital Output depends upon the baud rate.

**DIGITAL OUTPUT (FoxCom Only)**

The transmitter sends its measurement to the I/A Series System as a digital signal. Remote communications occur between the transmitter and the PC-based configurator, or any I/A Series System Console up to 600 m (2000 ft) away from the Fieldbus Module. Other specifications are:

- Data Transmission Rate - 4800 baud
- Scan Frequency - 10 times/second

**Functional Block Diagrams**

Refer to Figures 4 and 5 for a 4 to 20 mA Output functional block diagram for FoxCom and HART, and for a Digital Output functional block diagram for FoxCom only.

**Process Fluid Conductivity and Signal Cable Length**

The maximum allowable cable length is a function of the cable type, process fluid conductivity, and whether the cables are in the same or separate conduits. Standard system accuracy will be maintained when the installations are in accordance with Table 2.

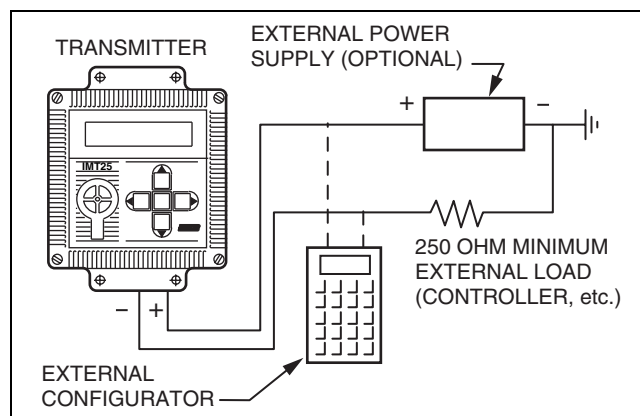

Figure 4. FoxCom and HART  
4 to 20 mA Output Functional Block Diagram

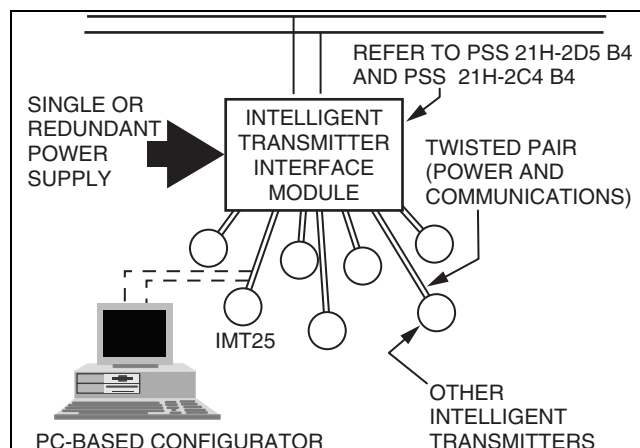

Figure 5. FoxCom Only  
Digital Output Functional Block Diagram

Table 2. Process Fluid Conductivity and Cabling

Maximum Cable Length(a)	Minimum Fluid Conductivity(a)	Signal and Coil Drive Cables
300 m (1000 ft)	5 $\mu$ S/cm	Signal and Coil Drive Cables in separate conduit. Signal Cable to be Foxboro Part No. R0101ZS (feet) or B4017TE (metres).
225 m (750 ft)	5 $\mu$ S/cm	Signal and Coil drive cables in same conduit. Signal Cable to be Foxboro Part No. R0101ZS (feet) or B4017TE (metres).
150 m (500 ft)	20 $\mu$ S/cm	Signal cable may be in same conduit as coil drive cable. Signal cable to be good quality twisted shielded pair, preferably no smaller than 1.0 mm <sup>2</sup> (or 18 AWG) for mechanical considerations (Belden 8760 or 9318, Alpha 5610/1801 or 5611/1801, or equivalent).

(a) Values in table are fluid conductivity minimums, and maximum distance between transmitter and flowtube. Refer to TI 027-072 for conductivities of various process liquids.

**PHYSICAL SPECIFICATIONS**

**Transmitter Enclosure**

The standard enclosure is a single compartment design which houses the electronics, power supply, and all field terminations. Provisions for four standard conduit/cable access holes (nonthreaded holes) are sized to accept 1/2 NPS or M20 fittings. These standard holes are located as indicated in the “Dimensions – Nominal” section. Two or four optional conduit/cable access holes can also be provided as indicated in the “Optional Selections and Accessories” section. The enclosure compartment is protected with a front gasketed cover which seals the unit. Upon removing the cover, a lanyard attached to both inside surfaces (of the cover and enclosure) retains the cover, thereby eliminating the misplacing or otherwise damaging of the cover assembly. This cast aluminum enclosure is weather-proof as defined by IEC IP66, and provides the watertight and corrosion resistant protection of NEMA Type 4X. Refer to the Optional Features section for information relating to a dual compartment enclosure that separates the field terminals from all other transmitter electronics.

**Enclosure Material**

Cast aluminum (1% copper content, maximum)

**Enclosure Finish**

Epoxy powder coat, gray

**Transmitter Mounting**

**PIPE MOUNTING**

Two integrally cast flanges at the top and bottom rear of the enclosure, together with a kit of stainless steel parts (by Foxboro), are used for mounting transmitter to a DIN 50 or 2 in pipe.

**SURFACE MOUNTING**

The two integral flanges used for pipe mounting can also be used to secure the transmitter to a wall or surface.

**FLOWTUBE MOUNTING**

This type of mounting is only applicable to transmitters used with 8000A and 9300A Series Flowtubes. In these installations, the transmitter is secured to the top surface of the flowtube using a mounting bracket and gasket seal.

**Mounting Position**

The transmitter can be mounted in any position without degrading performance. The front cover of the transmitter housing can be rotated in 90° increments to allow easy viewing of the display for any installation orientation.

**Approximate Mass - Transmitter Only**

**SINGLE COMPARTMENT TRANSMITTER**

2.9 kg (6.5 lb)

**DUAL COMPARTMENT TRANSMITTER**

3.9 kg (8.7 lb)

**INTRINSICALLY SAFE TRANSMITTER**

4.9 kg (10.9 lb)

**ELECTRICAL SAFETY SPECIFICATIONS**

Testing Laboratory, Types of Protection, and Area Classification	Application Conditions	Electrical Safety Design Code
CSA ordinary locations.	—	K
CSA Class I, Division 2, Groups A, B, C, and D; Class II, Division 2, Groups F and G; and Class III, Division 2 hazardous locations.	Temperature Class T4 at maximum ambient of 70°C.	L
FM ordinary locations.	—	M
FM nonincendive, Class I, Division 2, Groups A, B, C, and D; Class II, Division 2, Groups F and G; and Class III, Division 2 hazardous locations	Temperature Class T4 at maximum ambient of 70°C.	N
Testing Laboratory Approval or Certification <u>not</u> Required.	—	Z

## OPTIONAL SELECTIONS AND ACCESSORIES

### I/O Access Port and Cover

An I/O access port and cover allow access to two banana plugs that are provided for connection to the hand-held terminals or PC-based configurators. The access port cover not only protects the terminals from the environment, but is also marked to identify terminal functions. The cover is integrally attached to the front panel, thus preventing misplacement and loss of the cover when removed. Specify Optional Selection suffix -A.

### Protective Cover for Display and Keypad Panel

This hinged clear plastic cover protects the front panel display and keypad. The cover protects against inadvertent manipulation of the keys, and allows for “hose downs” of the transmitter housing. Specify Optional Selection suffix -B.

### Dual Compartment Enclosure

An optional secondary enclosure is available for those installations which require a sealed separation between the electronics and the field terminations. With this option, a separate field terminals compartment is provided which is sealed and separated from the primary electronics compartment. Therefore, all field terminations can be made by simply removing the terminations compartment cover without having to expose the electronics to the environment. The terminal strips contained in the secondary housing allow for easy wiring, installation, and replacement. Specify Optional suffix -C for a secondary housing with top insertion type terminal block, or Suffix -D for a secondary housing with lug type terminal block.

### Cable Glands for Nonconduit Applications

These 1/2 NPT cable glands provide a rain tight, strain relieved entrance for 6.8 to 12.2 mm (0.27 to 0.48 in) diameter cable. The body and seal nut are nylon and the compression gland is neoprene. Selectable using Model Code Option -G.

### Foxboro Signal Cable

For Remote-Mounted Transmitter only. Two-core (two-conductor), multiscreened (multi-shielded) cable with two driven screens (shields). Maximum length is 300 m (1000 ft). If expressing length in feet, order Part Number R0101ZS. If length units are metres, order Part Number B4017TE. Refer to Table 2 for recommended installation of this cable.

### Conduit/Cable Access Holes

As stated previously, four conduit/cable access holes are provided standard with the transmitter. Also, either two or four additional holes can be provided as shown and described in Figure 6 and the table below,

If You Specify	Then Added Holes Are Provided at
ECEP 14357-A	Locations 4 and 6
ECEP 14357-B	Locations 7 and 8
ECEP 14357-C	Locations 4, 6, 7, and 8

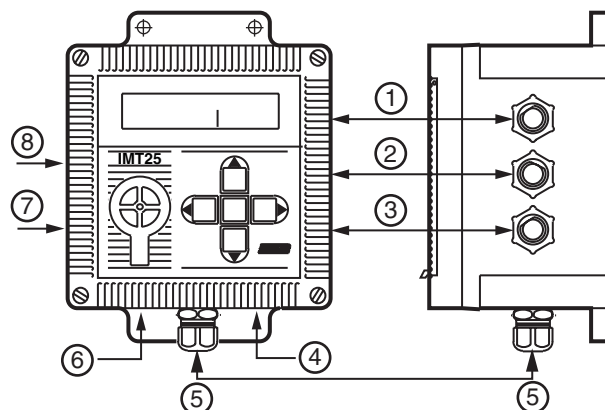

#### NOTES:

1. Standard holes 1, 2, 3, and 5 shown with Optional Glands.
2. Standard hole 5 is not offered with Flowtube Mounted Transmitter.
3. Optional holes 4 and 6 are not offered with Flowtube Mounting.
4. Plug all unused holes.

Figure 6. Location of Conduit/Cable Access Holes

**MODEL CODE**

<u>Description</u>	<u>Model</u>
I/A Series Magnetic Flow Transmitter	IMT25
<b><u>Transmitter Mounting</u></b>	
Pipe Mounting	-P
Surface or Wall Mounting	-S
Flowtube Mounting (a,b)	-I
<b><u>Language</u></b>	
English/German (Available only with FoxCom Protocol Selection D)	D
English Only (Available only with HART Protocol Selection T)	E
<b><u>Nominal Supply Voltage and Frequency</u></b>	
120 and 240 V ac, 50 and 60 Hz	A
24 V dc (c)	B
<b><u>Communication Protocols</u></b>	
FoxCom Communication Protocol	D
HART Communication Protocol	T
<b><u>Integral LCD Indicator/Keypad</u></b>	
Blind; No Indicator or Keypad	A
LCD Indicator with Keypad (e)	B
<b><u>Transmission Output Signal (f)</u></b>	
Internally Powered, 4 to 20 mA and Superimposed Digital (600 Baud FoxCom or 1200 Baud HART)	1
Externally Powered, 4 to 20 mA and Superimposed Digital (600 Baud FoxCom or 1200 Baud HART)	2
Internally Powered, 4800 Baud (FoxCom Protocol Code D only)	3
Externally Powered, 4800 Baud (FoxCom Protocol Code D only)	4
<b><u>Pulse Output Signal (f,g)</u></b>	
Off (Can be Reconfigured in the Field from OFF to ON)	0
On, Internally Powered	1
On, Externally Powered	2
<b><u>Electrical Safety (Also see "Electrical Safety Specifications" section)</u></b>	
CSA, Ordinary Locations	K
CSA, Class I, Division 2	L
FM, Ordinary Locations	M
FM, Nonincendive, n	N
No Testing Laboratory Approval or Certification Required	Z
<b><u>Optional Selections</u></b>	
I/O Access Port and Cover	-A
LCD Indicator/Keypad with a Clear Plastic Protective Guard (Cover)	-B
Dual Compartment Enclosure w/Top Insertion Type Terminal Block (h)	-C
Dual Compartment Enclosure w/Lug Type Terminal Block (h)	-D
Cable Glands for Nonconduit Applications (Cannot be used with Electrical Safety Code L and N)	-G
Example: IMT25-PEADA31K-AG	

- (a) Flowtube mounted transmitter may only be used with process temperatures not exceeding 120°C (250°F).
- (b) IMT25 can only be integrally mounted to 8000A and 9300A Series Flowtubes.
- (c) The 24 V dc selection requires a start-up current of at least 1.5 amperes.
- (d) For flowmeters with FOUNDATION Fieldbus Communication Protocol, see PSS 1-6F5 B.
- (e) The LCD Indicator has ambient temperature limits of -20 and +70°C (-4 and 158°F).
- (f) Internal versus external power can be changed in field by a switch setting.
- (g) Pulse output can be configured as either scaled pulse output mode or frequency output mode.
- (h) The electronics are in the main enclosure, and the customer terminations are in the secondary enclosure (terminations box).

**DIMENSIONS-NOMINAL**

**FLOWTUBE MOUNTED TRANSMITTER - SINGLE COMPARTMENT**

mm  
in

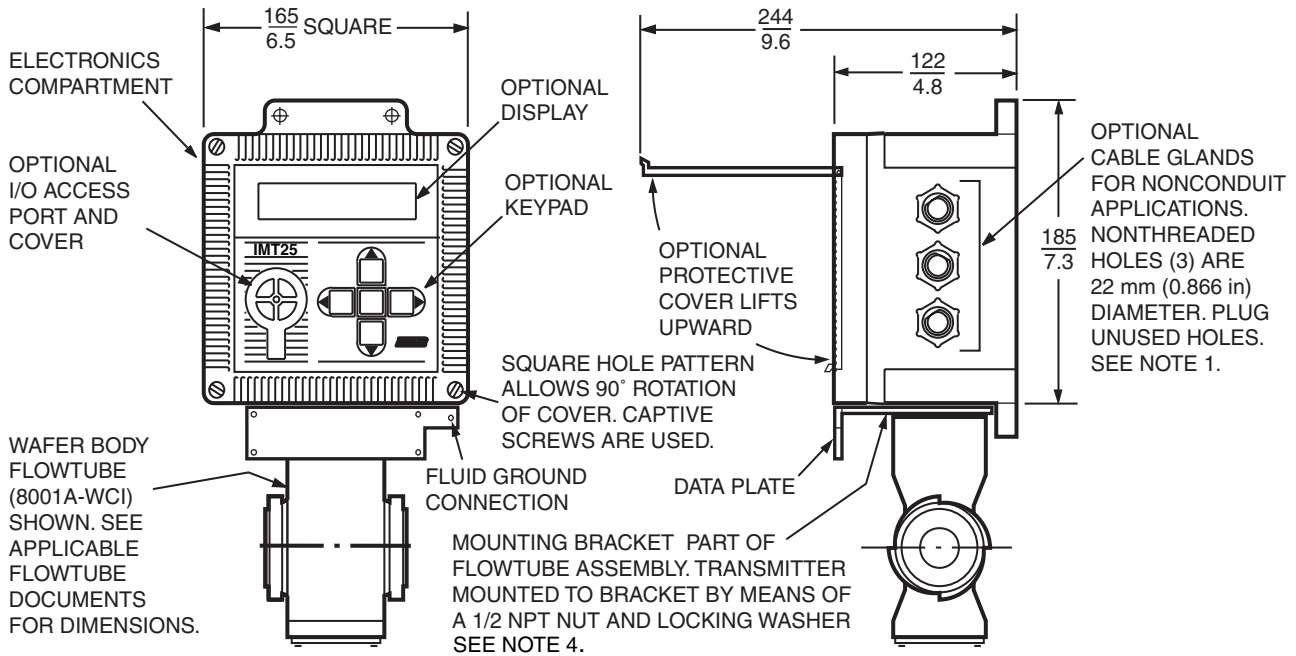

**FLOWTUBE MOUNTED TRANSMITTER - OPTIONAL DUAL COMPARTMENT**

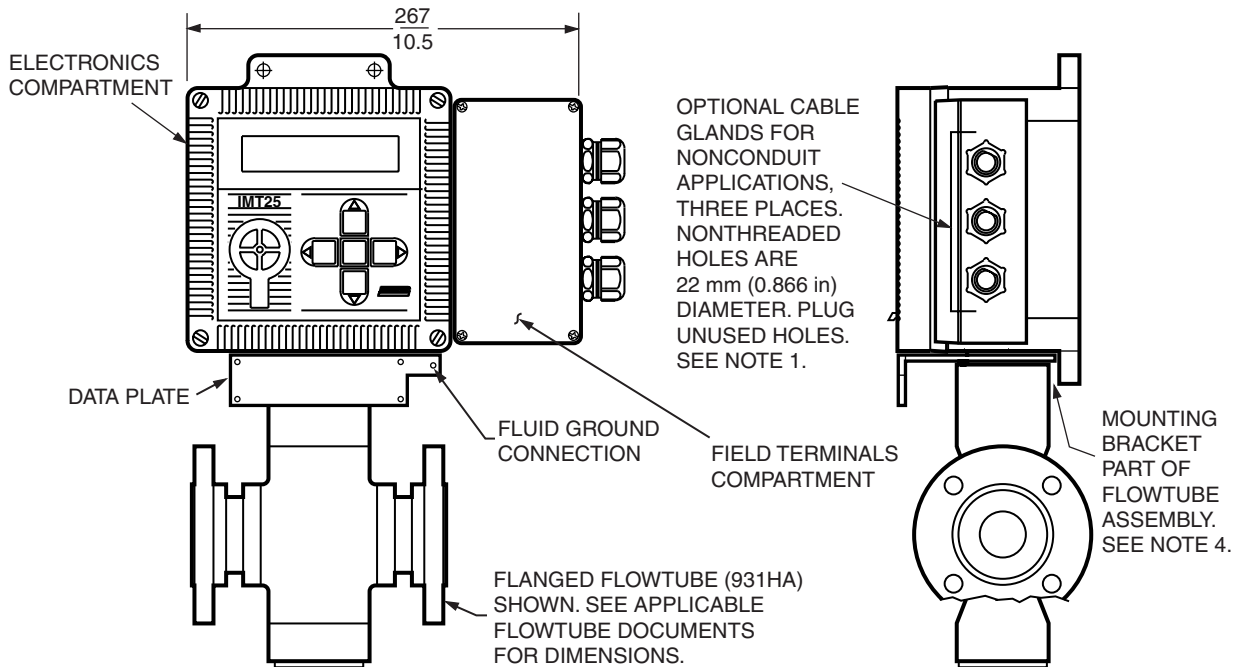

**NOTES:**

1. PLUG UNUSED CONDUIT CONNECTIONS (OR HOLES) WITH PLUGS TO MAINTAIN NEMA 4 MOISTURE AND DUST PROTECTION (SEE MI 021-387).
2. SIGNAL AND COIL DRIVE WIRING BETWEEN TRANSMITTER AND FLOWTUBE ARE PERFORMED BY FOXBORO AT PLANT OF MANUFACTURE WHEN BOTH UNITS ENTERED ON SAME ORDER.
3. SEE "OPTIONAL SELECTIONS" SECTION IF ADDITIONAL CONDUIT/CABLE ACCESS HOLES ARE REQUIRED.
4. FLOWTUBE ASSEMBLY MOUNTED AT FACTORY IN POSITION SHOWN, AND CAN BE ROTATED ±1/4 TURN. FACTORY-MOUNTED POSITION RECOMMENDED FOR 3 INCH AND SMALLER 8000A SERIES FLOWTUBES.

**DIMENSIONS—NOMINAL (Cont.)**

**SURFACE AND PIPE MOUNTED TRANSMITTER - SINGLE COMPARTMENT**

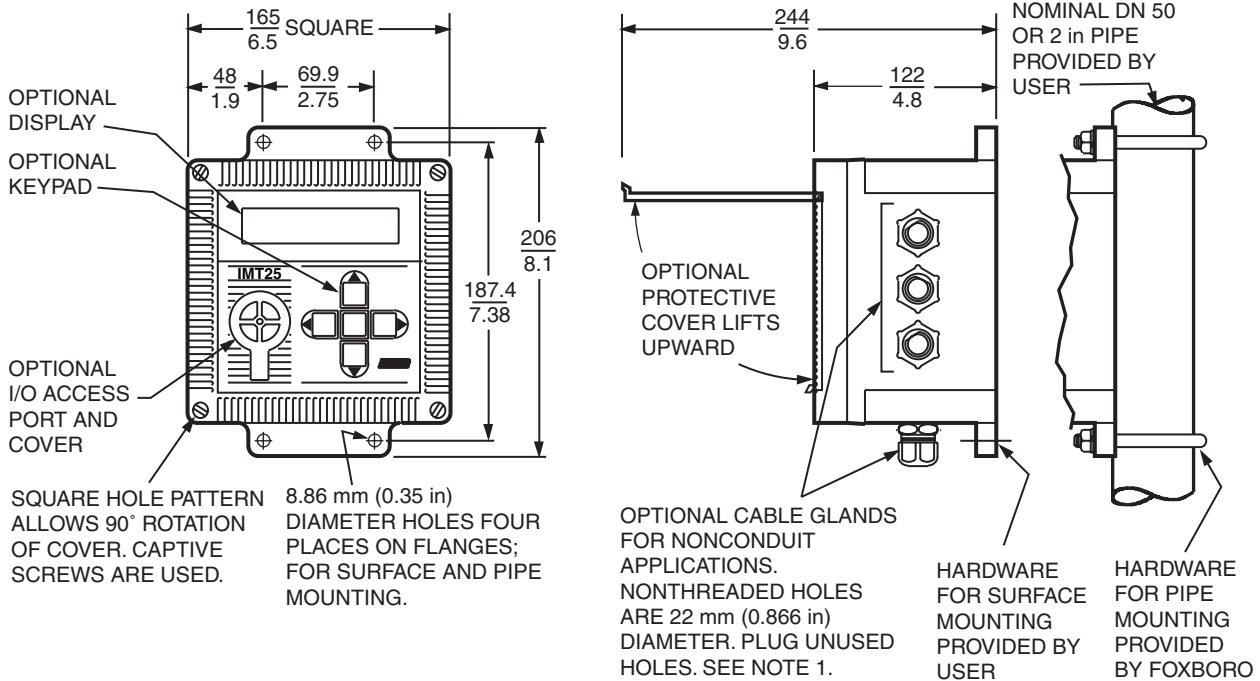

**SURFACE AND PIPE MOUNTED TRANSMITTER - OPTIONAL DUAL COMPARTMENT**

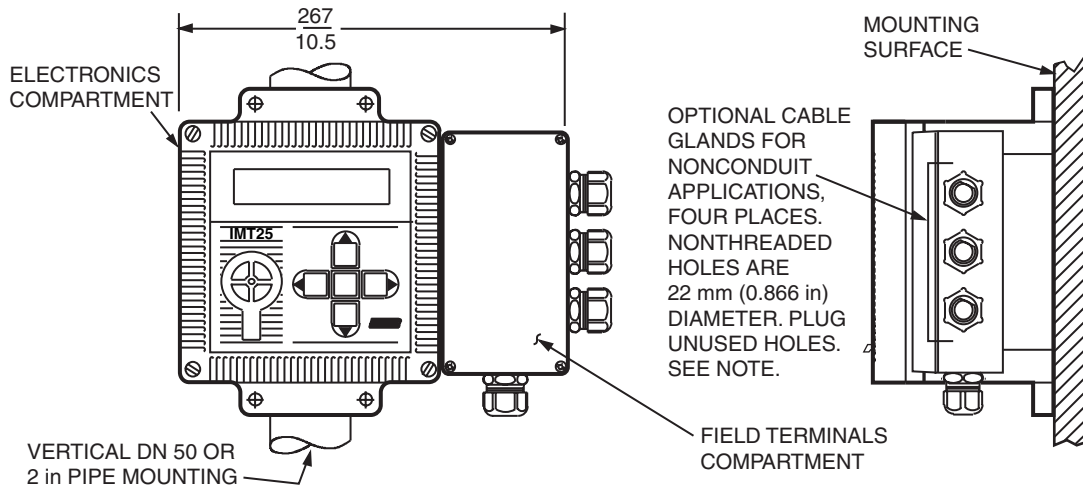

**NOTES:**

1. PLUG UNUSED CONDUIT CONNECTIONS (OR HOLES) WITH PLUGS TO MAINTAIN NEMA 4 MOISTURE AND DUST PROTECTION (SEE MI 021-387).
2. SEE "OPTIONAL SELECTIONS" SECTION IF ADDITIONAL CONDUIT/CABLE ACCESS HOLES ARE REQUIRED.

### **ORDERING INSTRUCTIONS**

1. Model Number
2. Signal Cable Part Number and Len
3. ECEP Number for Optional Conduit/Cable Access Holes
4. User Tag Data

### **OTHER M&I PRODUCTS**

Invensys Foxboro provides a broad range of measurement and instrument products, including solutions for pressure, flow, analytical, positioners, temperature, controlling and recording. For a listing of these offerings, visit the Invensys Foxboro web site at:

[www.foxboro.com/instrumentation](http://www.foxboro.com/instrumentation)

33 Commercial Street  
Foxboro, MA 02035-2099  
United States of America  
[www.foxboro.com](http://www.foxboro.com)  
Inside U.S.: 1-866-746-6477  
Outside U.S.: 1-508-549-2424  
or contact your local Foxboro  
representative.  
Facsimile: 1-508-549-4999

Invensys, Foxboro, FoxCom, and I/A Series are trademarks of Invensys plc, its subsidiaries, and affiliates.  
All other brand names may be trademarks of their respective owners.

Copyright 1996-2004 Invensys Systems, Inc.  
All rights reserved

MB 010

Printed in U.S.A.

0904